

# Wet Well Installation Instructions and Operating Guidelines

## 1. INTRODUCTION

1.1. It is the responsibility of the owner, installer and operator to follow all requirements contained in these instructions and to comply with all federal, state and local safety regulations that may apply to wet well installations and operations.

1.2. No instructions or procedures presented in this document should be interpreted so as to put at risk any person's health or safety, or to harm any property or the environment.

### **WARNING**

*Follow OSHA regulations for excavations. Collapse of excavation walls could result in death or serious injury.*

1.3. Working in and around excavations is dangerous. The Occupational Safety and Health Administration (OSHA) has specific requirements that must be followed. Prior to beginning work at the site, the installer should obtain a copy of OSHA's Standard, Part 1926 (Construction), Subpart P -Excavations. A copy of this standard is available free of charge at OSHA's Web site ([www.osha.gov](http://www.osha.gov)).

1.4. Careless activity or reckless operation of equipment can cause death, serious injury or property damage.

1.5. It is important to follow the procedures and instructions in this document in order to safely and properly install a Xerxes wet well. Failure to follow these instructions will void Xerxes' obligations under the limited warranty and may cause product failure, serious personal injury or property damage.

1.6. The Xerxes limited warranty applies only to a wet well installed according to these instructions. Since Xerxes does not control the parameters of any installation, Xerxes' sole responsibility in any installation is that presented in the limited warranty.

1.7. Comply with all applicable federal, state and local construction, health, safety and environmental codes, and industry standard practices.

1.8. For additional information, contact your state, county and city authorities having jurisdiction, including health, fire or building departments, and environmental agencies. All work must be performed according to standard industry practices and OSHA regulations.

1.9. Federal, state and local codes and regulations always take precedence over a Xerxes requirement.

1.10. Xerxes must authorize – in writing and prior to wet well installation – any variation to, or deviation from, these instructions.

1.11. All correspondence regarding variations must be retained for any warranty claim to be valid.

1.12. If you have questions or encounter situations not covered in these instructions, contact technical support at Xerxes Minneapolis, 952-887-1890.

## 2. PREPARATION FOR INSTALLATION

2.1. Although Xerxes wet wells are rugged, the wet well owner and/or the wet well owner's representative must take care so that the wet well is not dropped or damaged during delivery, unloading and handling on the jobsite.

2.1.1. Before unloading the wet well from the truck, the wet well owner and/or the wet well owner's representative must make sure that all tools or other items that may damage the wet well during unloading are removed from the trailer bed.

2.1.2. When unloading the wet well from the truck, the wet well owner and/or the wet well owner's representative must make sure that the wet well is secured in such a way that it does not roll off the truck.

### **WARNING**

*Do not allow driver to release straps securing the wet well to the truck until lifting equipment (such as a crane) is secured to the wet well's lifting lug(s). Failure to do so could result in death or serious injury.*

### **WARNING**

*Always chock the wet well. The wet well is heavy and has a large surface area. The wet well will roll on sloped surfaces and could be blown about by the wind. Movement of the wet well could result in death or serious injury.*

2.2. Before the wet well is unloaded or relocated on the jobsite, the wet well owner and/or the wet well owner's representative must complete the following steps:

2.2.1. Visually inspect the entire exterior surface of the wet well to make sure that no shipping or handling damage has occurred.

Look particularly for holes, cracks or deep scrapes.

2.2.1.1. If damage is detected, do not attempt repairs. Contact the UST coordinator at the Xerxes plant nearest you. Telephone and fax numbers are found in Section 10 of these instructions.

2.2.2. Sign the shipping papers accepting the wet well as delivered.

2.2.3. Be sure that all equipment used to lift the wet well is rated to handle the load.

2.2.4. Select a solid, level area to place the wet well, and clear that area of all rocks, trash and debris.

2.3. When hoisting the wet well, follow these instructions: (See *FIGURE 2-1* and *FIGURE 2-2*.)

2.3.1. When the wet well is not rotated (the wet well is upright), use all lifting lug(s) to unload and install the wet well. (See *FIGURE 2-2*.)

2.3.2. Some wet wells are rotated on the truck for shipping purposes. These wet wells have extra lifting lug(s) to aid in the loading/unloading process. (See *FIGURE 2-2*.)

**XERXES**<sup>®</sup>  
CORPORATION

7901 Xerxes Avenue South, Minneapolis, MN 55431-1288 ■ (952) 887-1890 ■ Fax (952) 887-1882 ■ [www.xerxescorp.com](http://www.xerxescorp.com)

© 2007 Xerxes Corporation

2.3.2.1. To unload these wet wells, use the lifting lugs that are situated on top of the wet well in its rotated position. To install the wet well, carefully rotate the wet well to its upright position and then use all lifting lugs situated on top of the wet well in its upright position. (See FIGURE 2-2.)

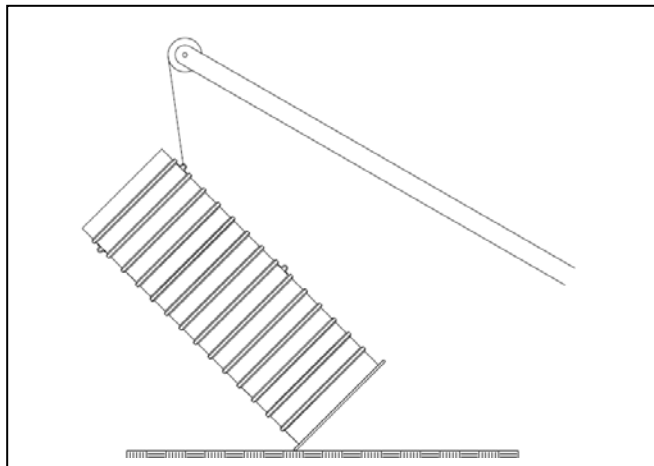

FIGURE 2-1

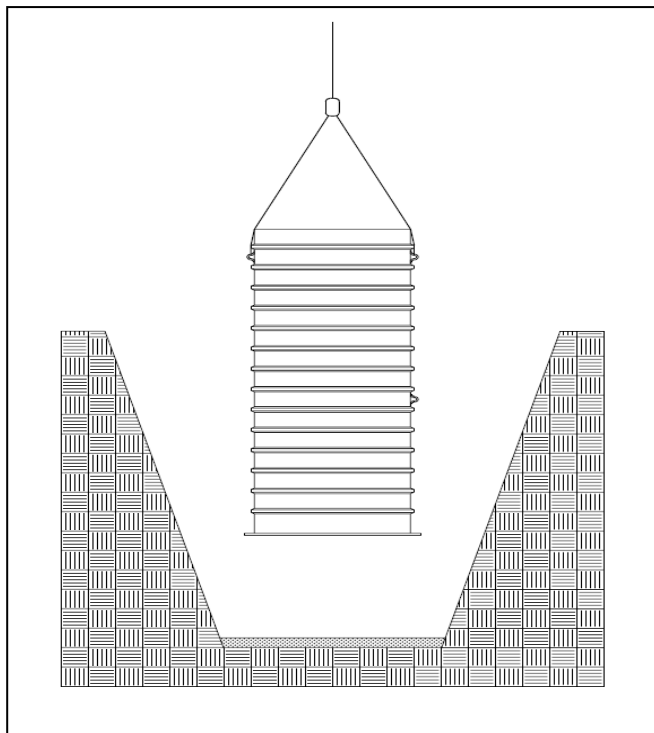

FIGURE 2-2

- 2.3.3. Do not wrap chain or cable around the wet well.
- 2.3.4. Use guy ropes to guide the wet well when needed.
- 2.3.5. Do not roll the wet well to move it.
- 2.4. Whenever a wet well is temporarily placed aboveground at the site, chock it in place to prevent rolling. Tie the wet well down if high winds are expected.
- 2.5. Whenever a wet well is temporarily placed above the ground in a situation in which there could be freezing temperatures, always take extra care so that water does not accumulate in a way that could result in damage to the wet well.

2.6. Excavate a hole large enough to accommodate basin, underground piping, backfill material, and adequate working space.

### 3. INSTALLATION

3.1. Xerxes wet well must be installed using either pea gravel or crushed stone as the backfill material. (See FIGURE 3-1.) For additional information, refer to the Xerxes document, Backfill Guidelines.

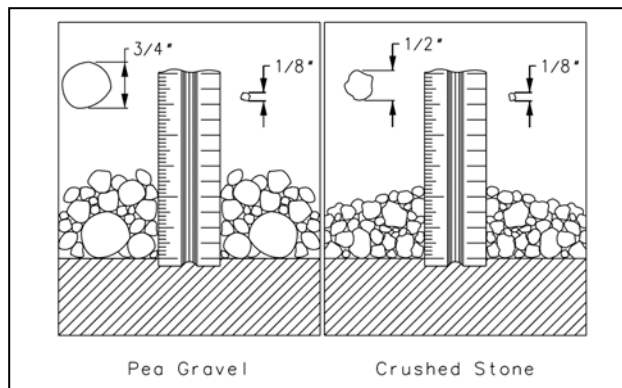

FIGURE 3-1

- 3.1.1. When using pea gravel, the material is to be a mix of rounded particles, sizes between 1/8 inch and 3/4 inch. The pea gravel must conform to the specifications of ASTM C-33, paragraph 9.1, sizes 6, 67 or 7.
- 3.1.2. When using crushed stone, the material is to be a mix of angular particles, sizes between 1/8 inch and 1/2 inch. The crushed stone must conform to the specifications of ASTM C-33, paragraph 9.1, sizes 7 or 8.
- 3.1.3. If material which meets these specifications is not available, contact technical support at Xerxes Minneapolis for information on alternate materials and the process for approval.

### 3.2. DRY-HOLE INSTALLATION

- 3.2.1. Prepare a smooth, level bed, 6 inches thick, of approved backfill material, or a concrete pad designed by a project engineer.
- 3.2.2. Place the wet well onto the bed or concrete pad.

### 3.3. WET-HOLE INSTALLATION

- 3.3.1. Before performing Point 3.2.1. of the dry-hole installation, pump the water from the hole and continue pumping to maintain minimum water level during wet well installation.
- 3.3.2. During Point 3.2.2. of the dry-hole installation, when setting the wet well, partially ballast the wet well until it settles firmly on the prepared bed. The ballast level in the wet well must never exceed the water level in the hole by more than 1 foot until the backfill reaches the top of the wet well.

### 3.4. DRY-HOLE AND WET-HOLE INSTALLATIONS

- 3.4.1. From the edge of the hole, bring the backfill up in the excavation. Approved backfill material must be used at least 12 inches around the entire periphery of the wet well.
- 3.4.2. Xerxes recommends the use of a geotextile fabric to help separate the select backfill from the in-situ soil.

#### 4. PIPING AND CONNECTIONS

4.1. All piping must conform to all applicable codes and standards.

#### CAUTION

*All connections to the wet well must be flexible. Provisions must be made to accommodate movement and misalignment between the piping and the wet well. Failure to do this may damage the wet well or surrounding property.*

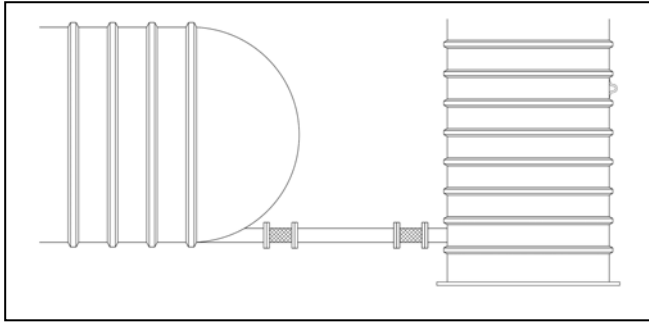

FIGURE 4-1

#### 5. OPTIONAL HYDROSTATIC TEST

- 5.1. Seal off influent and effluent piping with watertight caps or plugs.
- 5.2. Fill the wet well with water up to 3 inches into the access openings after the hole is backfilled at least 3/4 of the way up the wet well.
- 5.3. Let the water stand in the wet well for a minimum of 1 hour (or longer if required by applicable local codes).
- 5.4. If the water level drops, check to see that plugs or caps sealing off piping are tight and then add more water to fill air voids back to the standard testing level. (See Point 5.2.)
- 5.3. If water level does not stabilize, there may be a leak in the system. If damage is detected, do not attempt repairs. Contact the UST coordinator at the Xerxes plant nearest you. Telephone and fax numbers are found in Section 10 of this document.

#### 6. OPERATING GUIDELINES

- 6.1. Owner must retain the Wet Well Installation Instructions and Operating Guidelines for future reference to operating guidelines.
- 6.2. In addition to the Wet Well Installation Instructions and Operating Guidelines, follow all federal, state and local laws, regulations, codes and safety precautions that pertain to underground storage wet wells and/or their associated systems.
- 6.3. Consult the applicable limited warranty for each wet well for further operating guidelines and limitations. A copy of the limited warranty is available upon request from the UST coordinator at the Xerxes plant nearest you. (See SECTION 7.)
- 6.3. A Xerxes wet well is designed to store materials identified in the manufacturer's applicable limited warranty.

#### CAUTION

*Storing materials other than those identified in the manufacturer's applicable limited warranty will void Xerxes' obligation under the warranty and may cause wet well failure or property damage.*

6.4. Maximum temperature for storing wastewater products is 150° F.

#### CAUTION

*Storing a material in a wet well in excess of the allowable temperature may damage the wet well. Failure to follow this caution may damage the wet well and surrounding property.*

6.5. Do not allow anyone to enter the wet well unless it has been properly emptied and vented, and unless the person entering the wet well has been trained in confined-space entry procedures and applicable OSHA regulations.

#### WARNING

*Improper wet well entry could cause fire, explosion or asphyxiation and could result in death or serious injury.*

#### 7. LIMITED WARRANTIES

7.1. A copy of the relevant Xerxes limited warranty is found in the printed material that accompanies each wet well, in each applicable product brochure and on the Xerxes Web site ([www.xerxescorp.com](http://www.xerxescorp.com)). It is also available upon request from the UST coordinator at the plant nearest you.

#### 8. SUPPLEMENTAL MATERIALS

8.1. Supplemental materials, which may apply to specific installations and/or conditions, are available upon request from the UST coordinator at the Xerxes plant nearest you or from technical support at Xerxes Minneapolis (and on the Xerxes Web site at [www.xerxescorp.com](http://www.xerxescorp.com)).

#### 9. RETAINING INSTALLATION AND OPERATING GUIDELINES

9.1. After installation, wet well owner must retain the Wet Well Installation Instructions and Operating Guidelines for future reference to operating guidelines.

#### 10. CONTACTING XERXES

##### 10.1. CORPORATE OFFICE (TECHNICAL SUPPORT):

7901 Xerxes Avenue South  
Minneapolis, MN 55431-1288  
Phone: (952) 887-1890  
Fax: (952) 887-1870  
[www.xerxescorp.com](http://www.xerxescorp.com)

##### 10.2. MANUFACTURING FACILITIES:

**Anaheim, California**  
Phone: (714) 630-0012  
Fax: (714) 632-7133

**Hagerstown, Maryland**  
Phone: (301) 223-6933  
Fax: (301) 223-6836

**Seguin, Texas**  
Phone: (830) 372-0090  
Fax: (830) 372-0321

**Tipton, Iowa**  
Phone: (563) 886-6172  
Fax: (563) 886-2042