



**Rodney Hunt**  
A ZURN Company  
Rotovalve™ Cone Valve  
20 Questions

Rotovalve  
Cone Valve

20 Questions



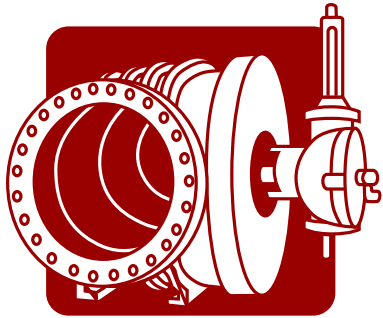

# 20

## Questions

1. What is a cone valve?
2. How does the Rotovalve cone valve operate?
3. What is the size availability for the Rotovalve?
4. What are the standard materials of construction?
5. Who makes the Rotovalve?
6. What experience and services can Rodney Hunt Company offer someone specifying a cone valve?
7. What are the chief differentiating features of the Rotovalve, and their benefit to the user?
8. Where are Rotovalves used? What media can they handle? What control functions do they meet?
9. What are the pressure, temperature, and velocity ranges for the Rotovalve?
10. What is water hammer? How can the Rotovalve help control it?
11. Why is the Rotovalve ideal for most "smaller than line size" applications?
12. What does the term "driptight" shutoff mean?
13. What does the term "skirted" mean when used in reference to the Rotovalve? What are the advantages of the fully skirted Rotovalve?
14. What is double seating? Is it necessary? Where are the two sets of seats?
15. What kind of actuation equipment can Rodney Hunt company supply with a Rotovalve?
16. What kind of valve actuation is the best?
17. Does actuation equipment need to be mounted in any particular way?
18. What accessories and special services are available?
19. What maintenance is required (or recommended) for the Rotovalve?
20. What spare parts should a user keep available?

# 1. What is a cone valve?

A cone valve is a rugged and highly dependable liquid control valve which can accurately modulate flows under extreme velocity, pressure, and temperature.

The cone valve is simple in basic configuration, and made up of three primary components (See Figure 1):

**1. Actuation Mechanism:** Serves the function of lifting and rotating the plug in the body.

**2. Plug:** Conically shaped element with a cylindrical bore (full pipe diameter).

**3. Body:** Supporting member for the plug. The body enables connection to adjacent piping or equipment, and supports the head which provides a mounting surface for the mechanism.

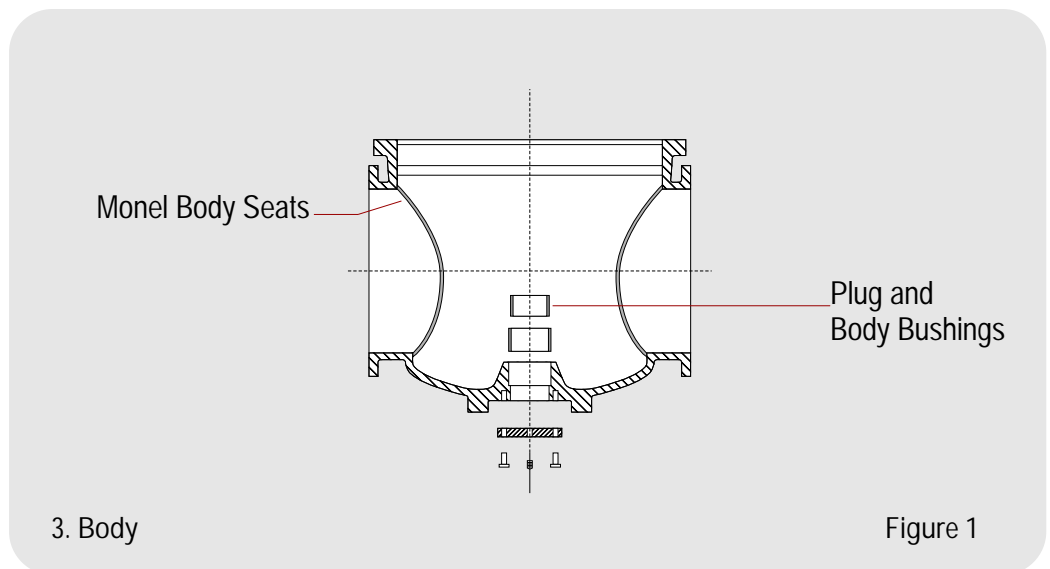
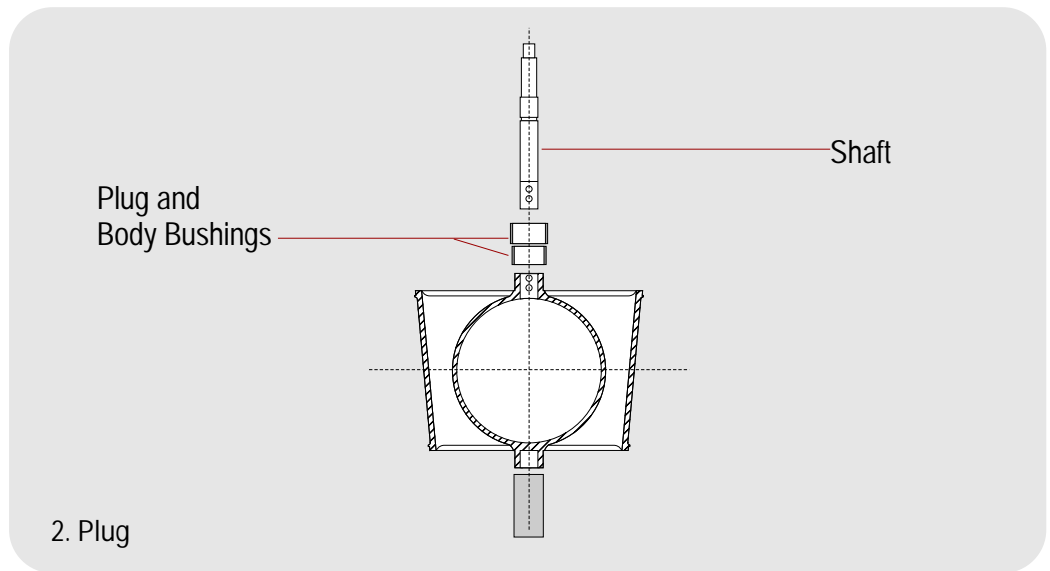
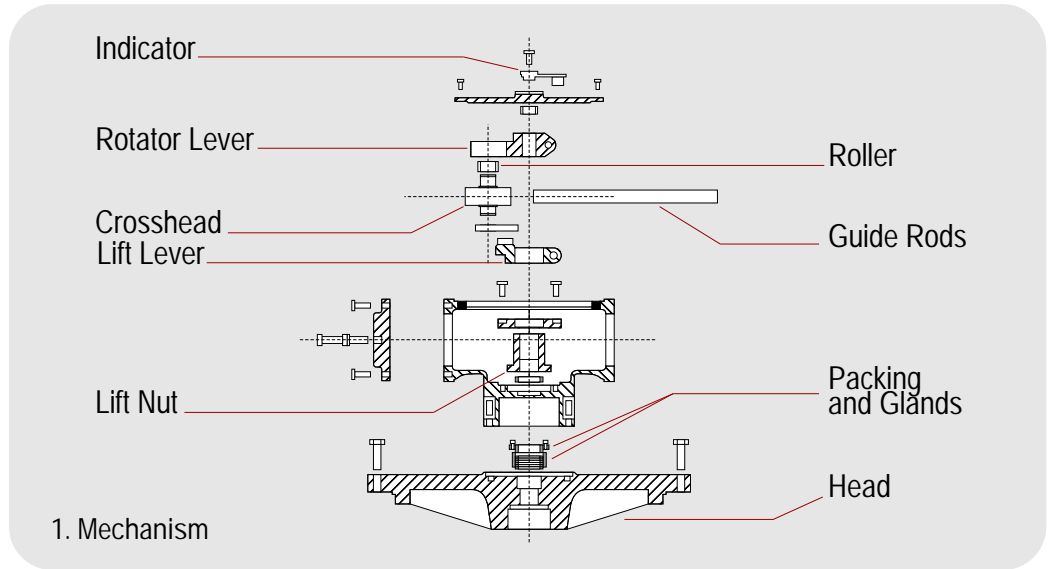

Figure 1

# 2. How does the cone valve operate?

The Rotovalve cone valve is different from other through-ported valves (like the ball valve) in its unique seating/unseating operation.

The plug is raised along the axis of the shaft to initiate opening of the valve, and lowered to complete closing of the valve (See Figure 3). This action permits the plug to rotate freely on journal bearings during the entire opening/closing sequence which reduces torque and eliminates seat wear.

**STEP 1. The closed position:** The Rotovalve seats drip-tight with the machined Monel faces on both sides of the plug seating against the machined Monel surfaces on each side of the body.

**STEP 2. Lift actuation:** The first movement of the actuator (manual, electric, or cylinder) moves the crosshead laterally toward the rotator lever. This initial lateral movement of the crosshead moves the lifter lever, which turns the lift nut and raises the plug away from the body seat. The plug has not turned.

**STEP 3. Opening:** once the crosshead contacts the rotator lever, further lateral movement of the crosshead then turns the plug.

**STEP 4. Opening:** Close-to-open, and open-to-close sequence can be adjusted for water hammer control. The two orifices of the valve (influent and effluent) drop the unbalanced pressure in two stages, reducing the potential for cavitation and vibration.

**STEP 5. Fully open:** once the plug is fully rotated, continued movement of the crosshead turns the lift nut, reseating the plug.

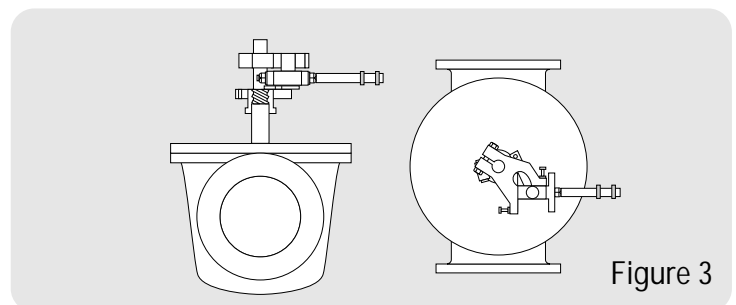
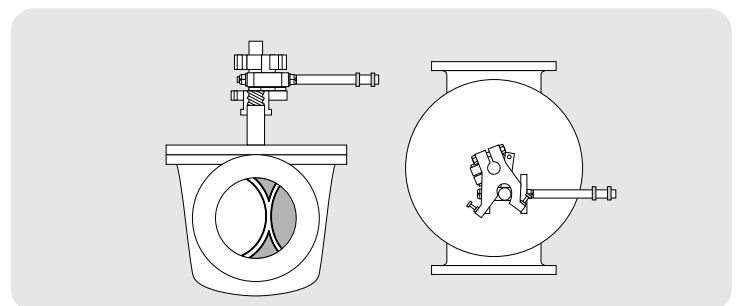
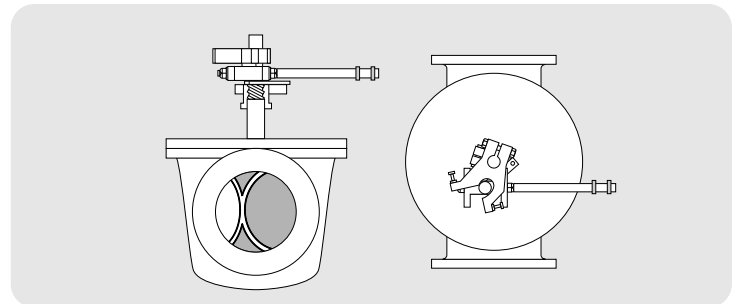
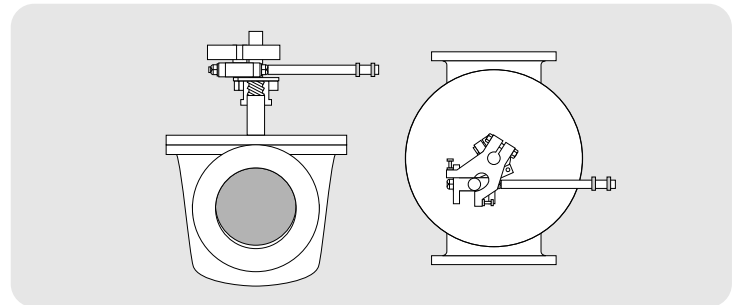
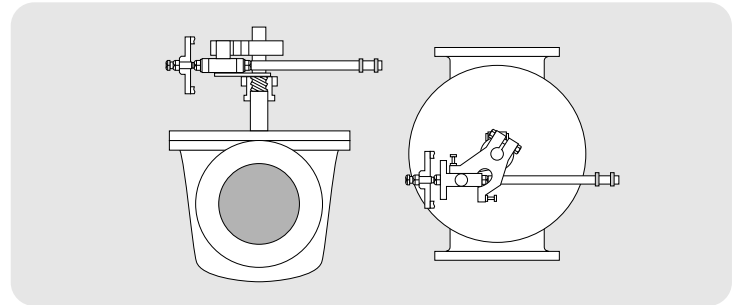

Actuator Mechanism Cross Section

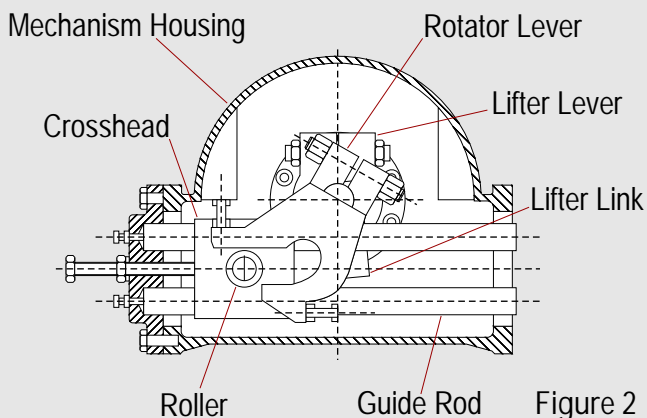

Figure 2

Figure 3

# 3. What is the size availability for the Rotovalve?



Standard sizes from 6"-48" are normally cast iron. Sizes 54" and larger are ductile iron,

cast or fabricated steel. The largest cone valve manufactured to date is 84".

# 4. What are the standard materials of construction?

Plug, Body, and Head.

Generally, the plug, body, and head materials of the Rotovalve are specified as follows:

0-150 psi	Cast Iron
150-250 psi	Ductile Iron
250-350 psi	Cast Steel

Special Applications.

Valves for special applications, larger (over 54") dimensions, and higher pressures/temperatures are either cast or fabricated steel.

Seats.

Plug and body seats are Monel. Monel has the properties necessary to handle all known applications. Monel seats are welded to the body and plug, then both the body and plug seats are machined to effect drip-tight shutoff.

Monel is a nickel/copper alloy. The high nickel content makes it the most corrosion resistant material that has all of the other characteristics required for this service. In comparison, stainless steel is a ferrous alloy, and not as corrosion resistant or weldable to cast iron.

# 5 . Who makes the Rotovalve?

---



Today, the Rotovalve cone valve is manufactured by Rodney Hunt Company, based upon designs and patterns acquired from AC Valve, Inc. The original design developed by S. Morgan Smith Company over 50 years ago was acquired by the Allis-Chalmers Corporation in 1959, and subsequently by AC Valve, Inc. (1988). In 1990, Rodney Hunt

Company acquired all product lines of AC Valve, Inc., including the Rotovalve cone valve.

The acquisition included inventory, patterns, drawings, engineering documentation, and sales records. This enables Rodney Hunt Company to supply parts and service as required for all new and existing Rotovalves.

# 6 . What experience and services can Rodney Hunt Company offer someone specifying a cone valve?

---

Rodney Hunt Company brings more than 150 years of engineering, manufacturing, and flow control experience to every project. In-house design, manufacturing, and testing capabilities include a fully equipped foundry, fabrication and machining facilities. Rodney

Hunt Company also has the ability to design and manufacture complete hydraulic operating systems for valve actuation and control, as well as providing field startup service if needed.

# 7 • What are the chief differentiating features of the Rotovalve, and their benefit to the user?

---

Feature	Benefit
Lift and Turn Operation	<ul style="list-style-type: none"> <li>■ Low torque, no seat wear.</li> </ul>
Full Circular Waterway Opening	<ul style="list-style-type: none"> <li>■ Lower pumping costs.</li> <li>■ Ability to pig.</li> </ul>
Rugged Construction, Simple Design	<ul style="list-style-type: none"> <li>■ Extremely low maintenance.</li> <li>■ Long life.</li> <li>■ Highly corrosion resistant seats.</li> </ul>
Precisely Machined Monel Body and Plug Seats	<ul style="list-style-type: none"> <li>■ Drip-tight shutoff.</li> <li>■ Long life.</li> </ul>
Fully Skirted	<ul style="list-style-type: none"> <li>■ Reduces potential for cavitation and vibration.</li> <li>■ Eliminates areas that trap sediments.</li> </ul>
Hydraulic Characteristics	<ul style="list-style-type: none"> <li>■ Precise flow control.</li> <li>■ Minimizes water hammer.</li> </ul>
Two Stage Pressure Reduction	<ul style="list-style-type: none"> <li>■ Ability to handle wide pressure ranges.</li> <li>■ Excellent for throttling applications.</li> </ul>

# 8

## • Where are Rotovalves used?

What media can they handle?

What control functions do they meet?

---

### Locations

Water Treatment and Transmission  
Wastewater Treatment  
Dams  
Steel Industry  
Process Plants  
Refineries  
Steam Power Plants  
Hydroelectric Power Plants  
Pump Stations  
Wind Tunnels  
Hydraulic Test Facilities

### Media

Water  
Wastewater  
Sludge and Slurry  
Air  
Gases  
Steam  
Oil

### Functions

Pump Check  
Stop Service  
Emergency Shutoff  
Pressure Regulation  
Level Regulation  
Pressure Modulation  
Velocity or Flow Modulation  
Turbine Control  
Vacuum Service  
Surge Control  
Energy Dissipation  
Smaller Than Line Size Service

Where precise control is required especially under extreme conditions such as high velocity, high pressure, speed of closing, or frequent operation.

# 9

## • What are the pressure, temperature, and velocity ranges for the Rotovalve?



### Pressure

"Standard" pressure classes can be summarized as follows:  
150 psi-cast iron  
250 psi-cast iron  
300 psi-cast steel

There is virtually no pressure limitation for a custom engineered Rotovalve. 10" valves have been designed and supplied to NASA that operate at 3,200 psi.

### Temperature

Recommended temperature range is minus 30°F to steam applications. Special materials can be provided to meet specific applications.

### Velocity

Essentially there is no maximum velocity. The Rotovalve can perform with long life in applications where the velocity is 50-100 feet per second.

# 10

## • What is water hammer? How can the Rotovalve help control it?

Water hammer, a phenomenon occurring in pipe lines carrying incompressible fluids, is attributed to a sudden change in the velocity change could be caused by the closing or opening of a valve, which would cause a series of pressure "pulsations" in the line. These pulsations are comparable to a bouncing spring, alternately compressing and decompressing. Unless precautions are taken, the intensity of the first wave (pulsation) can sometimes break the pipe. When designing a pipe line, the possibility of water hammer should always be taken into account.

Two of the primary causes of water hammer are as follows:

- At the discharge side of a pump, when the pump stops suddenly due to loss of power.
- When a valve closes of those fluids. Such a quickly.

Every water hammer problem is different, and must be considered on a case-by-case basis. In most situations, slowing the speed of valve closure will greatly reduce the dangers of water hammer.

Because of the Rotovalve's ability to withstand liquids moving at high velocities, and to precisely control valve opening/closing speeds, the Rotovalve is highly effective in handling these potentially dangerous water hammer conditions.

# 11 . Why is the Rotovalve ideal for most "smaller than line size" applications?

The primary reason is that the Rotovalve is a full port valve, and when fully open provides full flow-through characteristics. When a Rotovalve is installed in a Venturi type arrangement ("smaller than line size"), head loss can be kept to a minimum.

Another reason is that when a smaller valve is installed in a pipeline, higher velocities will result, allowing more precise flow control. In this situation, the Rotovalve has distinct performance advantages over other quarter-turn valves:

- The valve is fully skirted, eliminating sediment entrapment and ensuring that all flow passes through the port. Full skirting also reduces the potential for cavitation that can occur with other valves.

- The metal seating of the Rotovalve withstands high velocities, which may cause failure of resilient seats.
- There are two points of pressure reduction in the valve the inlet and the outlet orifices. This reduces the potential for vibration and cavitation and results in more precise control.

"Smaller than line size" installations provide cost savings to the user in permitting the use of a smaller (and less expensive) valve, as well as the potential for downsizing the entire facility.

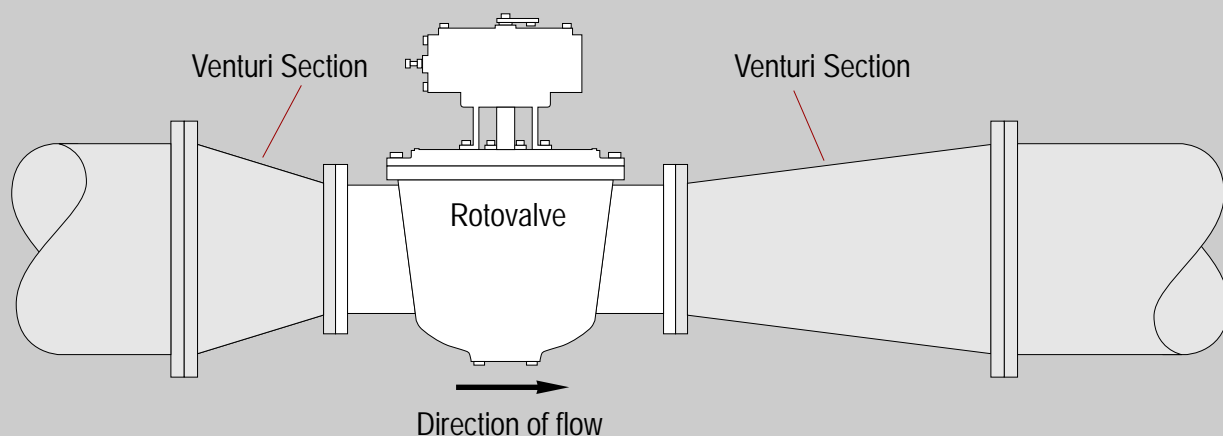

Figure 4