

Sectional View

Models EVMU(L)3 2 – EVMU(L)3 12

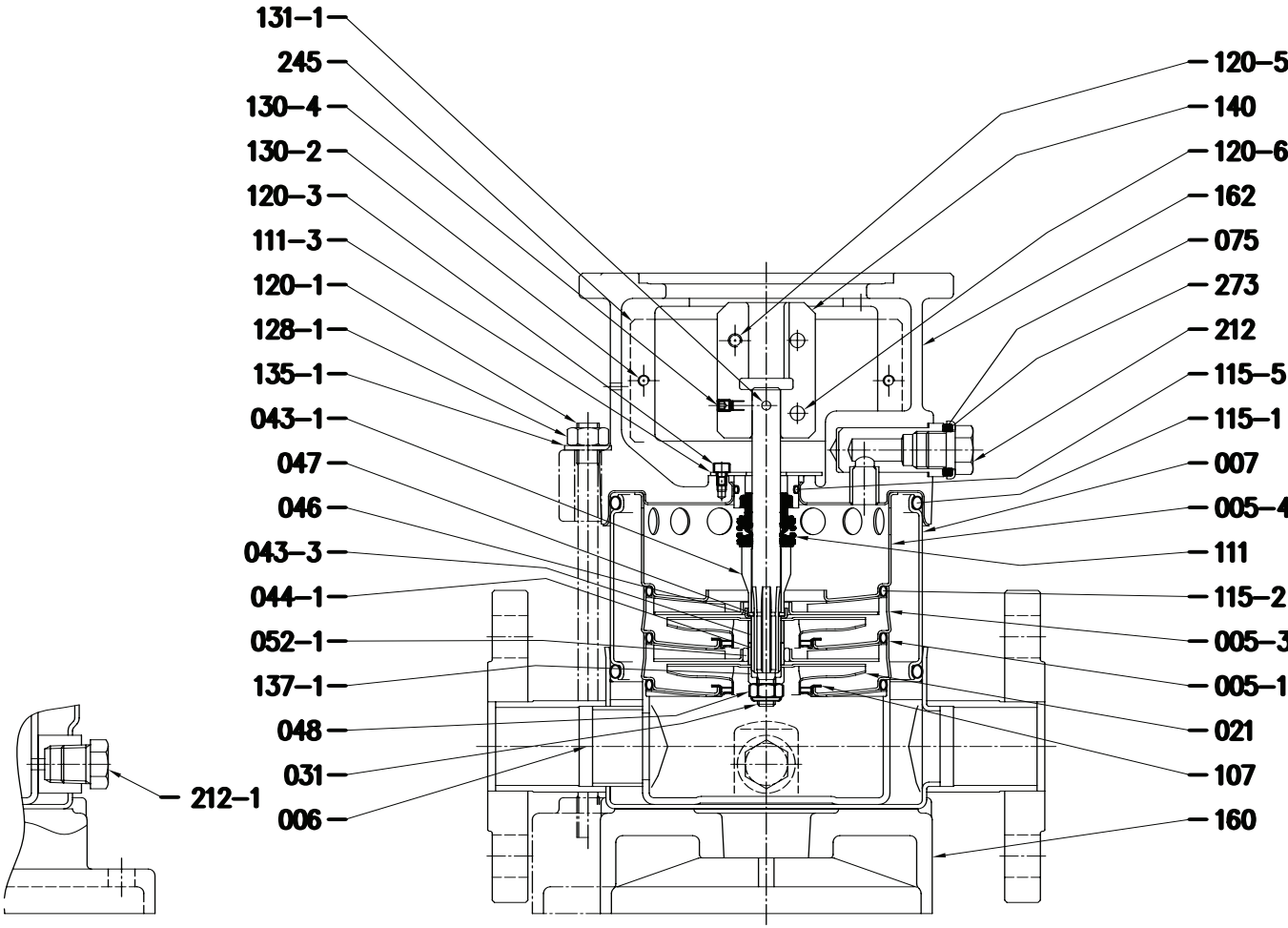

Refer to page 828 for material details.

(For reference only. See pricing for part availability.)

Sectional View

Models EVMU(L)3 13 – EVMU(L)3 18

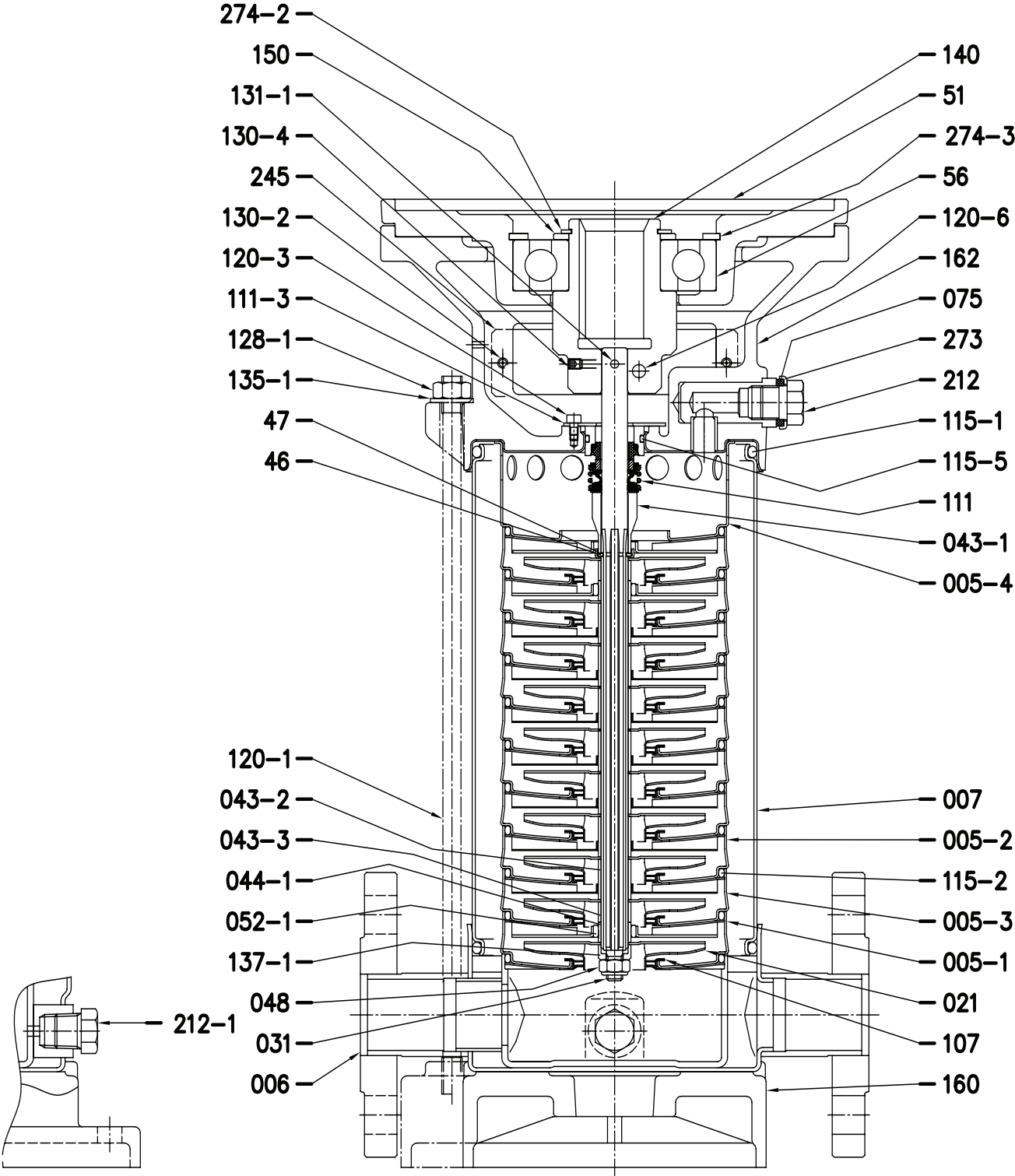

Refer to page 828 for material details.

(For reference only. See pricing for part availability.)

Sectional View

Models EVMU(L)5 2 – EVMU(L)5 6

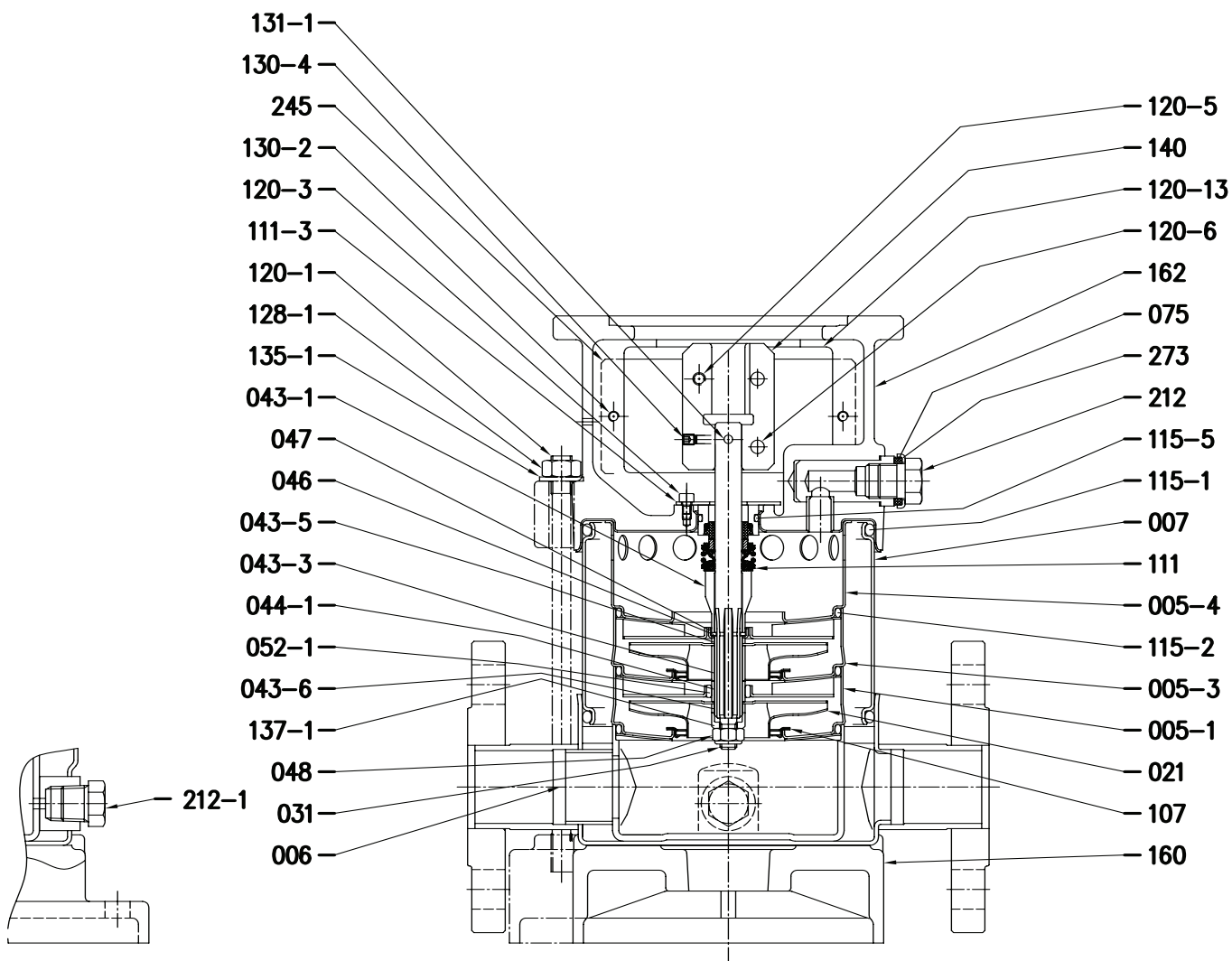

Refer to page 828 for material details.

(For reference only. See pricing for part availability.)



Sectional View

Models EVMU(L)5 7 – EVMU(L)5 16

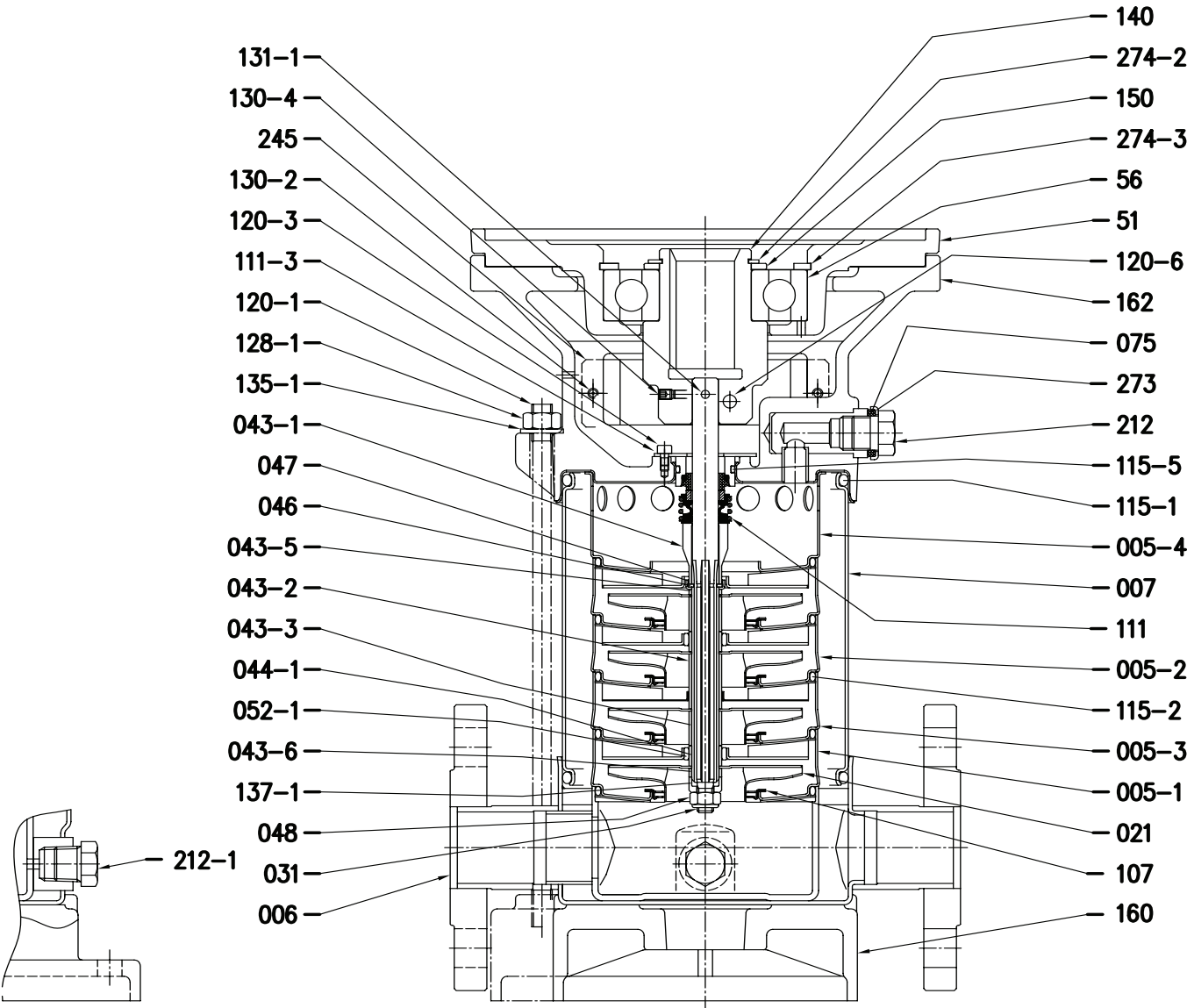

Refer to page 828 for material details.

(For reference only. See pricing for part availability.)

Sectional View – part reference
**Models EVMU(L)3
EVMU(L)5**

N°	Part name	Material	
		EVMU	EVMUL
005-1	Suction casing	EN 1.4301(AISI 304)	EN 1.4401 (AISI 316)
005-2	Intermediate casing	EN 1.4301(AISI 304)	EN 1.4401 (AISI 316)
005-3	Intermediate casing bearing	EN 1.4301(AISI 304)	EN 1.4401 (AISI 316)
005-4	Discharge casing	EN 1.4301(AISI 304)	EN 1.4401 (AISI 316)
006	Bottom casing	EN 1.4301(AISI 304)	EN 1.4401 (AISI 316)
007	Outer casing	EN 1.4301(AISI 304)	EN 1.4401 (AISI 316)
021	Impeller	EN 1.4301(AISI 304)	EN 1.4401 (AISI 316)
031	Shaft	EN 1.4401 (AISI 316)	
043-1	Shaft sleeve (mechanical seal)	EN 1.4301(AISI 304)	EN 1.4401 (AISI 316)
043-2	Shaft sleeve (intermediate)	EN 1.4301(AISI 304)	EN 1.4401 (AISI 316)
043-3	Shaft sleeve (bearing)	EN 1.4301(AISI 304)	EN 1.4401 (AISI 316)
043-5	Shaft sleeve (last stage)	EN 1.4301(AISI 304)	EN 1.4401 (AISI 316)
043-6	Shaft sleeve (adjustment)	EN 1.4301(AISI 304)	EN 1.4401 (AISI 316)
044-1	Shaft sleeve bearing	Tungsten carbide	
046	Split ring (mechanical seal)	EN 1.4301(AISI 304)	EN 1.4401 (AISI 316)
047	Ring holder	EN 1.4301(AISI 304)	EN 1.4401 (AISI 316)
048	Impeller nut	A2-70 UNI 7323 with inox insert	A4-70 UNI 7323 with inox insert
051	Motor adapter	Cast iron EN-GJL-200-EN 1561	
052-1	Bearing	Tungsten carbide	
056	Ball bearing		
070-1	Ring for bearing	EN 1.4301(AISI 304)	
075	O-ring (plug)	FPM	
075-1	O-ring (plug)	FPM	
107	Liner ring	PTFE/EN 1.4401 (AISI 316)	
111	Mechanical seal	Silicon carbide/Carbon/FPM	
111-3	Mechanical seal seat	EN 1.4301(AISI 304)	EN 1.4401 (AISI 316)
115-1	O-ring (outer casing)	FPM	
115-2	O-ring (intermediate casing)	FPM	
115-5	O-ring	FPM	

(For reference only. See pricing for part availability.)



Sectional View – part reference
**Models EVMU(L)3
EVMU(L)5**

N°	Part name	Material	
		EVMU	EVMUL
120-1	Tie rod	Zincate steel	
120-3	Screw	A2-70 UNI 7323	
120-5	Screw for coupling	Zincate steel 8.8 strength class ISO 898/1	
120-6	Screw for coupling	Zincate steel 8.8 strength class ISO 898/1	
128-1	Nut for tie rod	Zincate steel	
130-2	Screw for coupling guard	A2-70 UNI 7323	
130-4	Set-screw	Carbon steel	
131-1	Pin for shaft	Carbon steel	
135-1	Washer	Zincate steel	
135-4	Washer (bearing)	Carbon steel	
137-1	Impeller spacer	EN 1.4301(AISI 304)	EN 1.4401 (AISI 316)
140	Coupling	Brass OT 58 UNI 5705	
150	Spacer	Carbon steel	
160	Base	Cast iron EN-GJL-200-EN 1561	
162	Motor bracket	Cast iron EN-GJL-200-EN 1561+ EN 1.4301(AISI 304)	Cast iron + EN 1.4401 (AISI 316)
169	Motor adapter	Cast iron EN-GJL-200-EN 1561	
212	Plug	EN 1.4301(AISI 304)	EN 1.4401 (AISI 316)
212-1	Plug	EN 1.4301(AISI 304)	EN 1.4401 (AISI 316)
245	Coupling guard	EN 1.4301(AISI 304)	
273	Washer (plug)	EN 1.4301(AISI 304)	EN 1.4401 (AISI 316)
273-1	Washer (plug)	EN 1.4301(AISI 304)	/
274-2	C-type snap ring (coupling)	EVMU3 13, EVMU5 7 ,8	Carbon steel TC 80
		EVMU3 15, 18, EVMU5 10 to 16	
274-3	C-type snap ring (bracket)	EVMU3 13, EVMU5 7 ,8	Carbon steel TC 80
		EVMU3 15, 18, EVMU5 10 to 16	

(For reference only. See pricing for part availability.)



Sectional View

Models EVMU(L)10 2 – EVMU(L)10 3

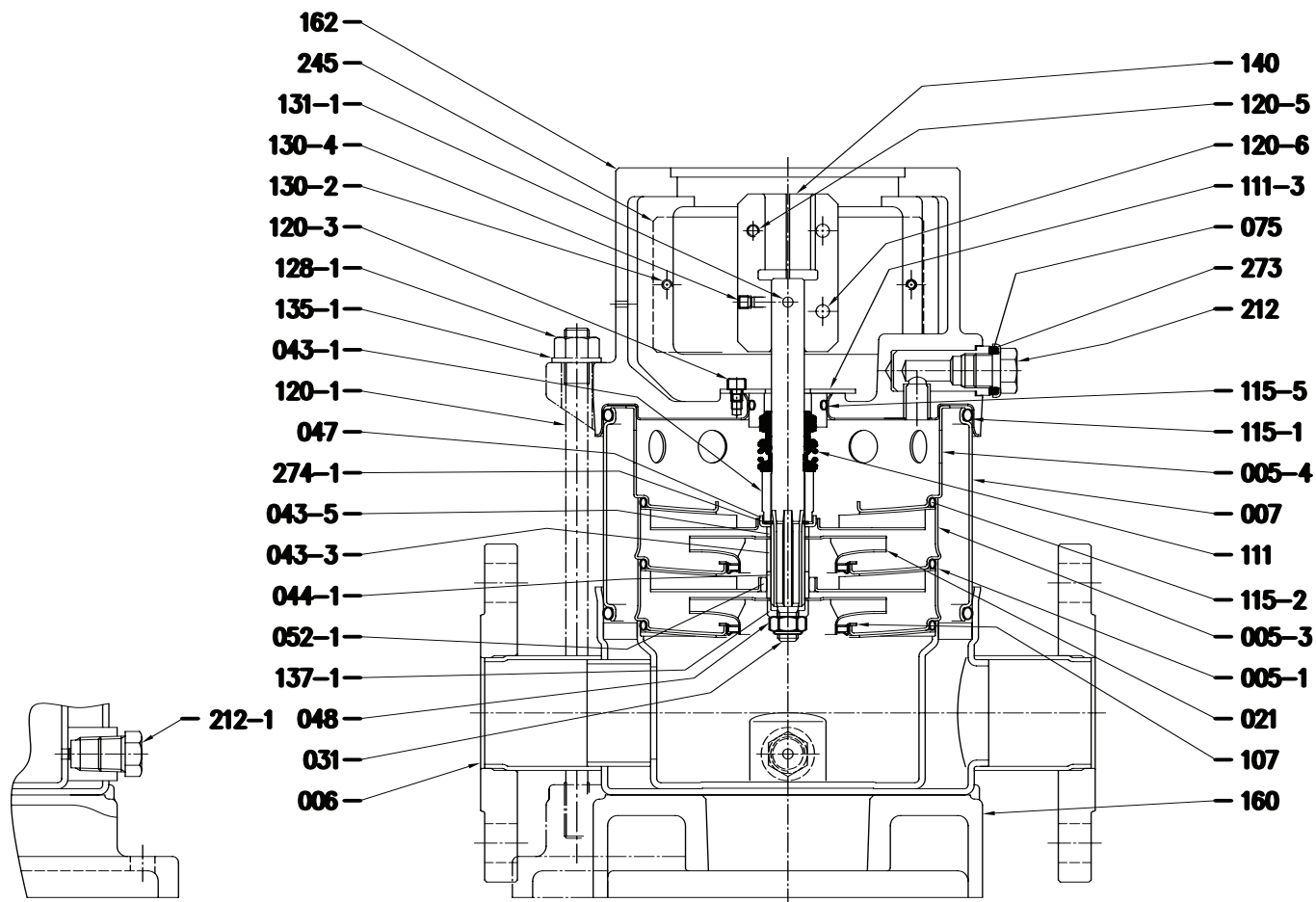

Refer to page 836 for material details.

(For reference only. See pricing for part availability.)



Sectional View

Models EVMU(L)10 4 – EVMU(L)10 12

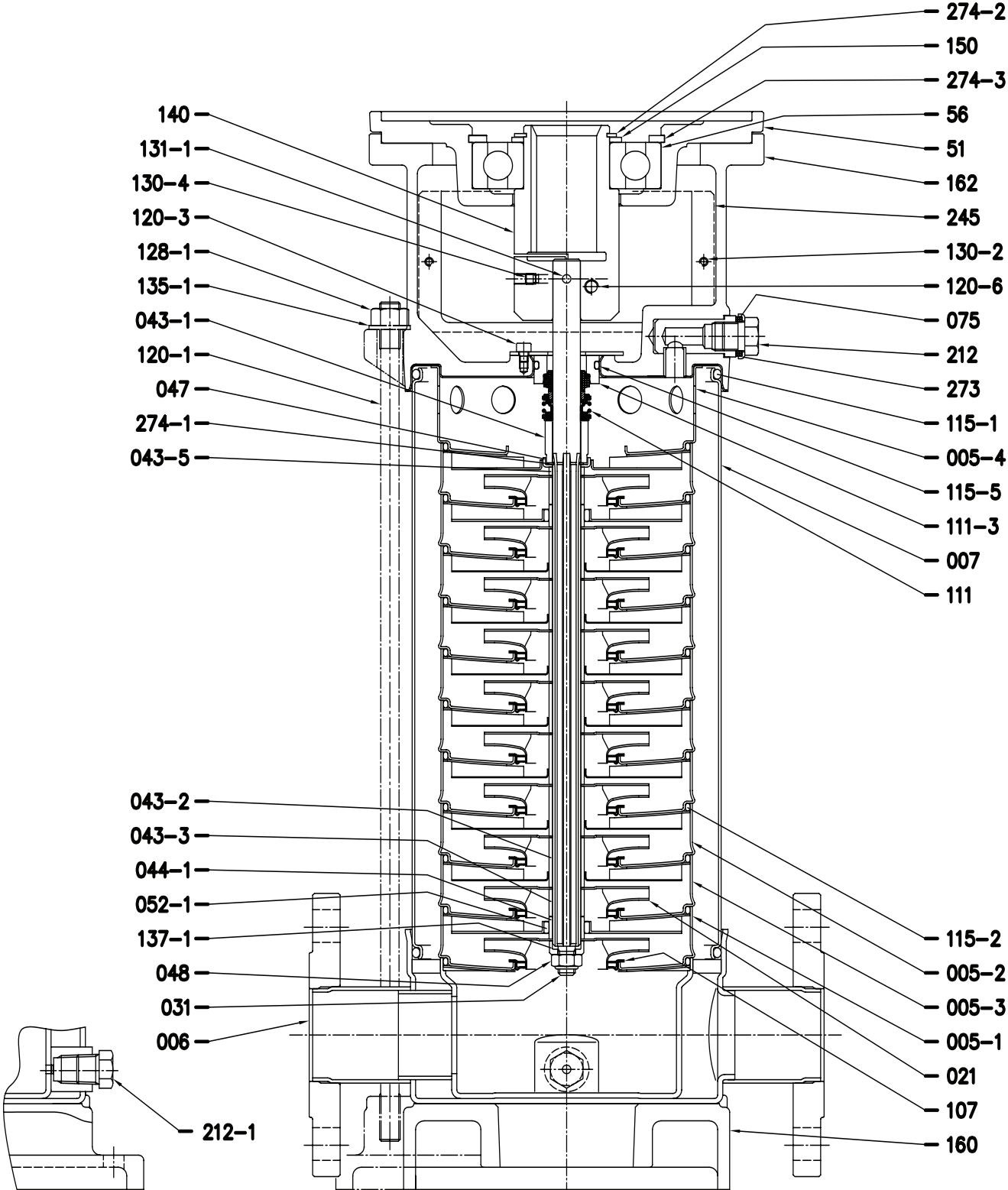

Refer to page 836 for material details.

(For reference only. See pricing for part availability.)

Sectional View

Models EVMU(L)10 14 – EVMU(L)10 16

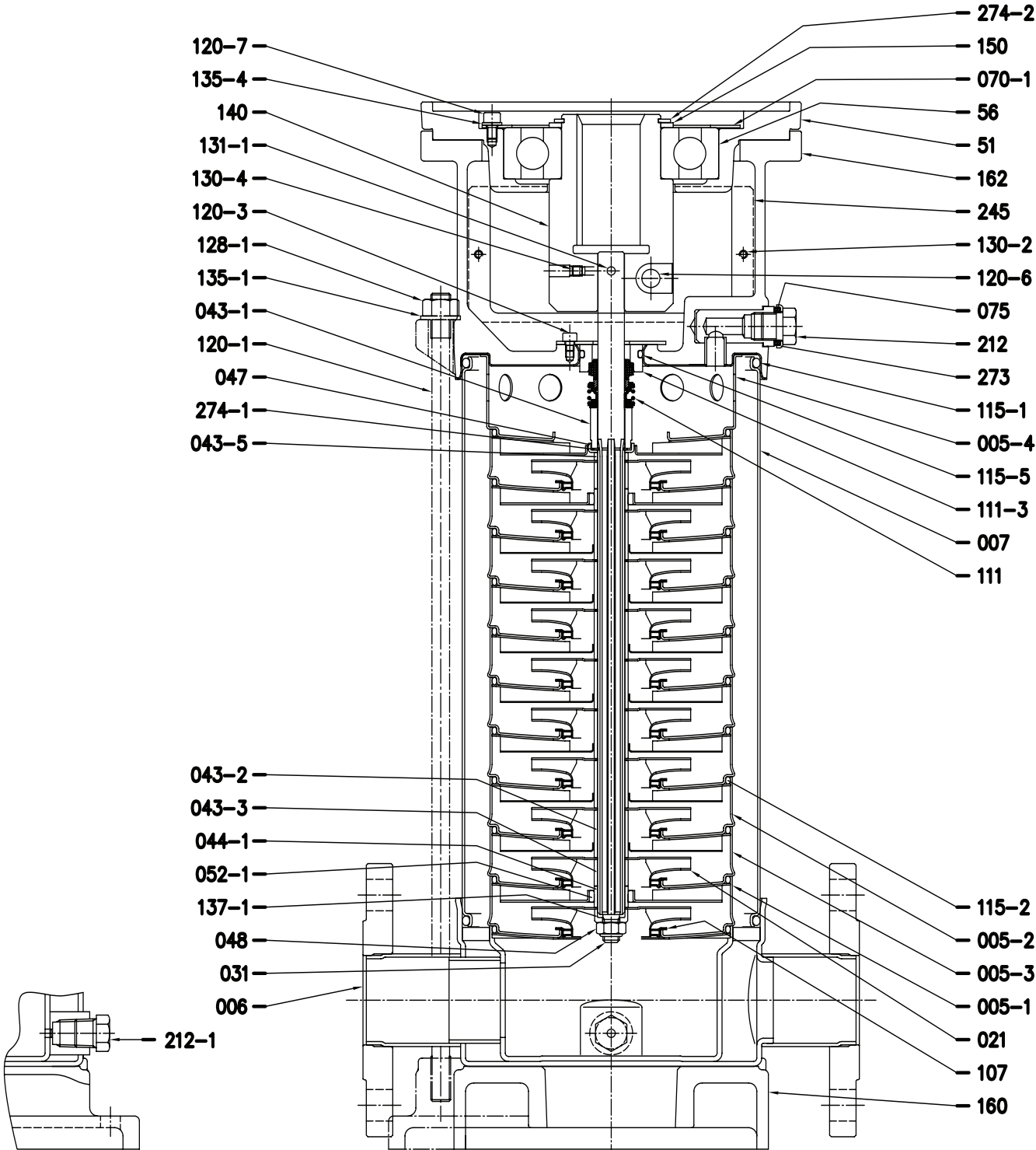

Refer to page 836 for material details.

(For reference only. See pricing for part availability.)

Sectional View

Models EVMU(L)18 2

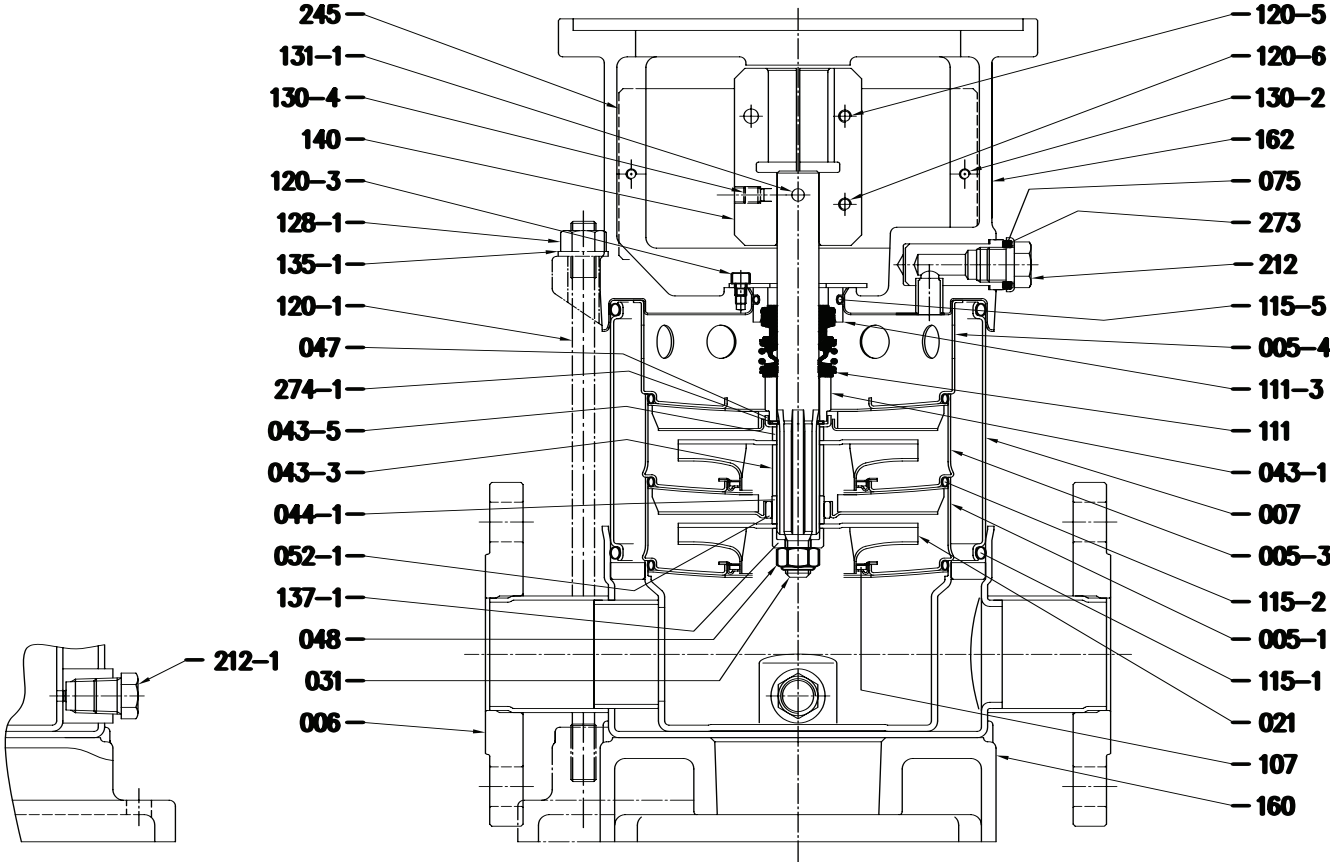

Refer to page 838 for material details.

(For reference only. See pricing for part availability.)

Sectional View

Models EVMU(L)18 3 – EVMU(L)18 5

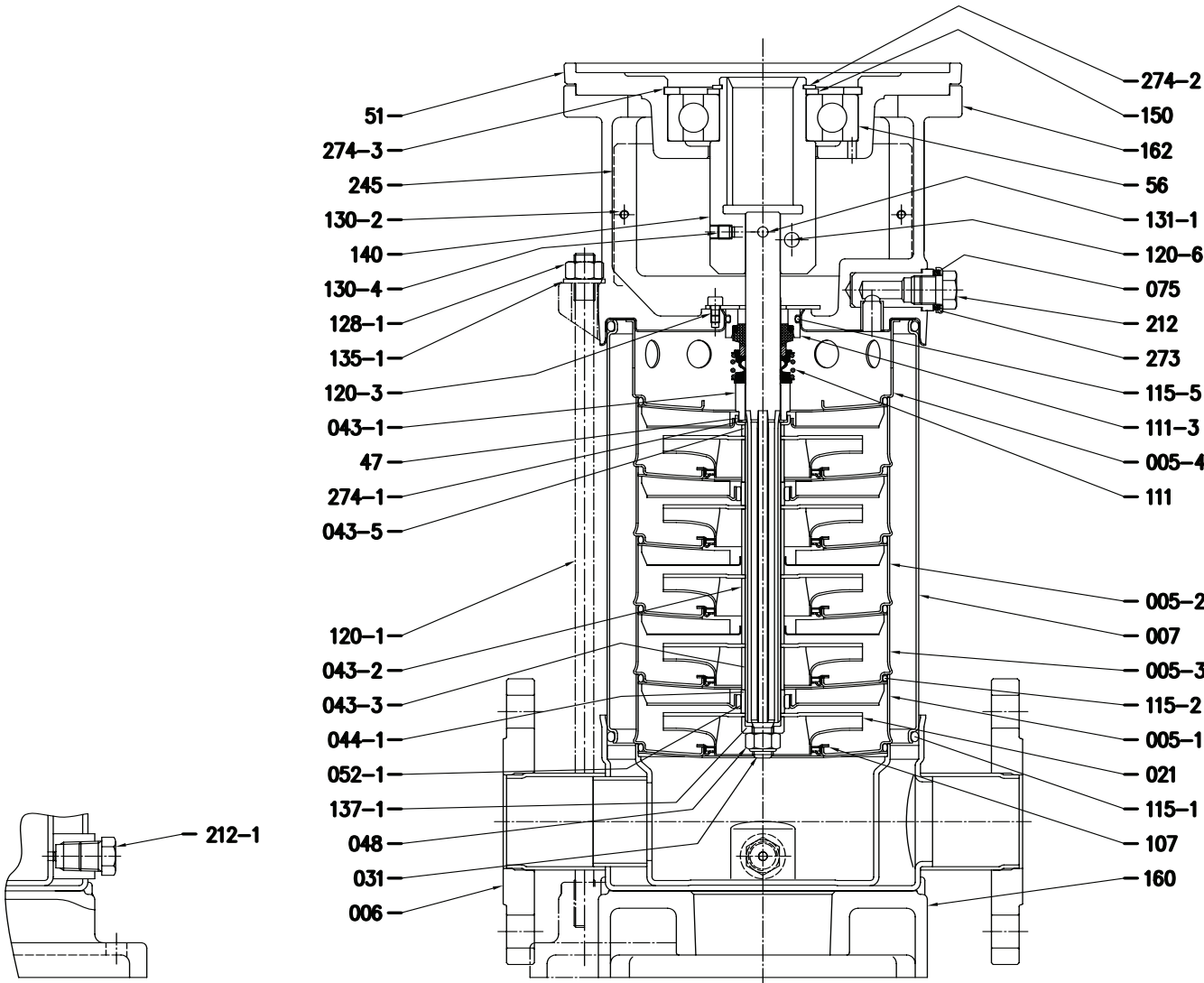

Refer to page 838 for material details.

(For reference only. See pricing for part availability.)

Sectional View

Models EVMU(L)18 6 – EVMU(L)18 11

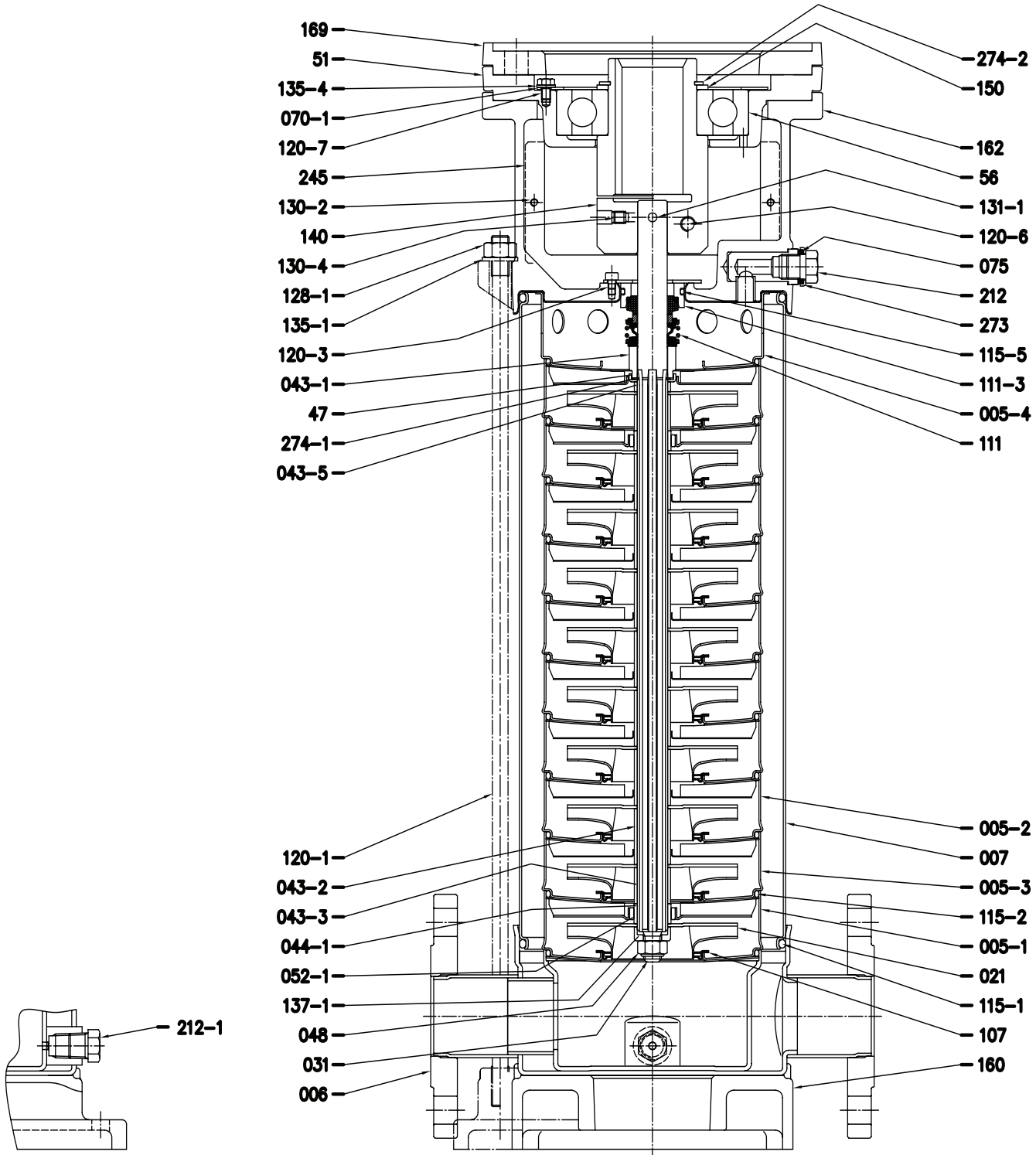

Refer to page 838 for material details.

(For reference only. See pricing for part availability.)

N°	Part name	Material	
		EVMU	EVML
005-1	Suction casing	EN 1.4301(AISI 304)	EN 1.4401 (AISI 316)
005-2	Intermediate casing	EN 1.4301(AISI 304)	EN 1.4401 (AISI 316)
005-3	Intermediate casing bearing	EN 1.4301(AISI 304)	EN 1.4401 (AISI 316)
005-4	Discharge casing	EN 1.4301(AISI 304)	EN 1.4401 (AISI 316)
006	Bottom casing	EN 1.4301(AISI 304)	EN 1.4401 (AISI 316)
007	Outer casing	EN 1.4301(AISI 304)	EN 1.4401 (AISI 316)
021	Impeller	EN 1.4301(AISI 304)	EN 1.4401 (AISI 316)
031	Shaft	EN 1.4401 (AISI 316)	
043-1	Shaft sleeve (mechanical seal)	EN 1.4301(AISI 304)	EN 1.4401 (AISI 316)
043-2	Shaft sleeve (intermediate)	EN 1.4301(AISI 304)	EN 1.4401 (AISI 316)
043-3	Shaft sleeve (bearing)	EN 1.4301(AISI 304)	EN 1.4401 (AISI 316)
043-5	Shaft sleeve (last stage)	EN 1.4301(AISI 304)	EN 1.4401 (AISI 316)
043-6	Shaft sleeve (adjustment)	EN 1.4301(AISI 304)	EN 1.4401 (AISI 316)
044-1	Shaft sleeve bearing	Tungsten carbide	
046	Split ring (mechanical seal)	EN 1.4301(AISI 304)	EN 1.4401 (AISI 316)
047	Ring holder	EN 1.4301(AISI 304)	EN 1.4401 (AISI 316)
048	Impeller nut	A2-70 UNI 7323 with inox insert	A4-70 UNI 7323 with inox insert
051	Motor adapter	Cast iron EN-GJL-200-EN 1561	
052-1	Bearing	Tungsten carbide	
056	Ball bearing	See table pag. 500	
070-1	Ring for bearing	EN 1.4301(AISI 304)	
075	O-ring (plug)	FPM	
075-1	O-ring (plug)	FPM	/
107	Liner ring	PTFE/EN 1.4401 (AISI 316)	
111	Mechanical seal	Silicon carbide/Carbon/FPM	
111-3	Mechanical seal seat	EN 1.4301(AISI 304)	EN 1.4401 (AISI 316)
115-1	O-ring (outer casing)	FPM	
115-2	O-ring (intermediate casing)	FPM	
115-5	O-ring	FPM	

(For reference only. See pricing for part availability.)



N°	Part name	Material	
		EVMU	EVML
120-1	Tie rod	Zincate steel	
120-3	Screw	A2-70 UNI 7323	
120-5	Screw for coupling	Zincate steel 8.8 strength class ISO 898/1	
120-6	Screw for coupling	EVMU10 2, EVMU10 3	
		EVMU10 4 to12	
		EVMU10 14 to16	
120-7	Screw (bearing)	Zincate steel 8.8 strength class ISO 898/1	
128-1	Nut for tie rod	Zincate steel	
130-2	Screw for coupling guard	A2-70 UNI 7323	
130-4	Set-screw	Carbon steel	
131-1	Pin for shaft	Carbon steel	
135-1	Washer	Zincate steel	
135-4	Washer (bearing)	Carbon steel	
137-1	Impeller spacer	EN 1.4301(AISI 304)	EN 1.4401 (AISI 316)
140	Coupling	Brass OT 58 UNI 5705	
150	Spacer	Carbon steel	
160	Base	/	Cast iron EN-GJL-200-EN 1561
162	Motor bracket	Cast iron EN-GJL-200-EN 1561+ EN 1.4301(AISI 304)	Cast iron + EN 1.4401 (AISI 316)
169	Motor adapter	Cast iron EN-GJL-200-EN 1561	
212	Plug	EN 1.4301(AISI 304)	EN 1.4401 (AISI 316)
212-1	Plug	EN 1.4301(AISI 304)	EN 1.4401 (AISI 316)
245	Coupling guard	EN 1.4301(AISI 304)	
273	Washer (plug)	EN 1.4301(AISI 304)	EN 1.4401 (AISI 316)
273-1	Washer (plug)	EN 1.4301(AISI 304)	/
274-1	C-type snap ring (coupling)	EN 1.4301(AISI 304)	EN 1.4401 (AISI 316)
274-2	C-type snap ring (coupling)	EVMU10 4	
		EVMU10 5 to 8	
		EVMU10 10 to 12	
		EVMU10 14 to16	
274-3	C-type snap ring (bracket)	EVMU10 4	
		EVMU10 5 to 8	
		EVMU10 10 to 12	

(For reference only. See pricing for part availability.)



N°	Part name	Material	
		EVMU	EVML
005-1	Suction casing	EN 1.4301(AISI 304)	EN 1.4401 (AISI 316)
005-2	Intermediate casing	EN 1.4301(AISI 304)	EN 1.4401 (AISI 316)
005-3	Intermediate casing bearing	EN 1.4301(AISI 304)	EN 1.4401 (AISI 316)
005-4	Discharge casing	EN 1.4301(AISI 304)	EN 1.4401 (AISI 316)
006	Bottom casing	EN 1.4301(AISI 304)	EN 1.4401 (AISI 316)
007	Outer casing	EN 1.4301(AISI 304)	EN 1.4401 (AISI 316)
021	Impeller	EN 1.4301(AISI 304)	EN 1.4401 (AISI 316)
031	Shaft	EN 1.4401 (AISI 316)	
043-1	Shaft sleeve (mechanical seal)	EN 1.4301(AISI 304)	EN 1.4401 (AISI 316)
043-2	Shaft sleeve (intermediate)	EN 1.4301(AISI 304)	EN 1.4401 (AISI 316)
043-3	Shaft sleeve (bearing)	EN 1.4301(AISI 304)	EN 1.4401 (AISI 316)
043-5	Shaft sleeve (last stage)	EN 1.4301(AISI 304)	EN 1.4401 (AISI 316)
043-6	Shaft sleeve (adjustment)	EN 1.4301(AISI 304)	EN 1.4401 (AISI 316)
044-1	Shaft sleeve bearing	Tungsten carbide	
046	Split ring (mechanical seal)	EN 1.4301(AISI 304)	EN 1.4401 (AISI 316)
047	Ring holder	EN 1.4301(AISI 304)	EN 1.4401 (AISI 316)
048	Impeller nut	A2-70 UNI 7323 with inox insert	A4-70 UNI 7323 with inox insert
051	Motor adapter	Cast iron EN-GJL-200-EN 1561	
052-1	Bearing	Tungsten carbide	
056	Ball bearing	See table pag. 500	
070-1	Ring for bearing	EN 1.4301(AISI 304)	
075	O-ring (plug)	FPM	
075-1	O-ring (plug)	FPM	/
107	Liner ring	PTFE/EN 1.4401 (AISI 316)	
111	Mechanical seal	Silicon carbide/Carbon/FPM	
111-3	Mechanical seal seat	EN 1.4301(AISI 304)	EN 1.4401 (AISI 316)
115-1	O-ring (outer casing)	FPM	
115-2	O-ring (intermediate casing)	FPM	
115-5	O-ring	FPM	

(For reference only. See pricing for part availability.)



N°	Part name	Material	
		EVMU	EVML
120-1	Tie rod	Zincate steel	
120-3	Screw	A2-70 UNI 7323	
120-5	Screw for coupling	Zincate steel 8.8 strength class ISO 898/1	
120-6	Screw for coupling	EVMU18 2	
		EVMU18 3 to 5	
		EVMU18 6 to 11	
120-7	Screw (bearing)	Zincate steel 8.8 strength class ISO 898/1	
128-1	Nut for tie rod	Zincate steel	
130-2	Screw for coupling guard	A2-70 UNI 7323	
130-4	Set-screw	Carbon steel	
131-1	Pin for shaft	Carbon steel	
135-1	Washer	Zincate steel	
135-4	Washer (bearing)	Carbon steel	
137-1	Impeller spacer	EN 1.4301(AISI 304)	EN 1.4401 (AISI 316)
140	Coupling	Brass OT 58 UNI 5705	
150	Spacer	Carbon steel	
160	Base	Cast iron EN-GJL-200-EN 1561	
162	Motor bracket	Cast iron EN-GJL-200-EN 1561+ EN 1.4301(AISI 304)	Cast iron + EN 1.4401 (AISI 316)
169	Motor adapter	Cast iron EN-GJL-200-EN 1561	
212	Plug	EN 1.4301(AISI 304)	EN 1.4401 (AISI 316)
212-1	Plug	EN 1.4301(AISI 304)	EN 1.4401 (AISI 316)
245	Coupling guard	EN 1.4301(AISI 304)	
273	Washer (plug)	EN 1.4301(AISI 304)	EN 1.4401 (AISI 316)
273-1	Washer (plug)	EN 1.4301(AISI 304)	/
274-1	C-type snap ring (coupling)	EN 1.4301(AISI 304)	EN 1.4401 (AISI 316)
274-2	C-type snap ring (coupling)	EVMU18 3 to 4	
		EVMU18 5	
		EVMU18 6 to 10	
		EVMU18 11	
274-3	C-type snap ring (bracket)	EVMU18 3 to 4	
		EVMU18 5	

(For reference only. See pricing for part availability.)



Model EVMUG / EVMUL
Sectional View

EBARA Stainless Steel Vertical Multistage

Model EVMUG32
EVMUL32

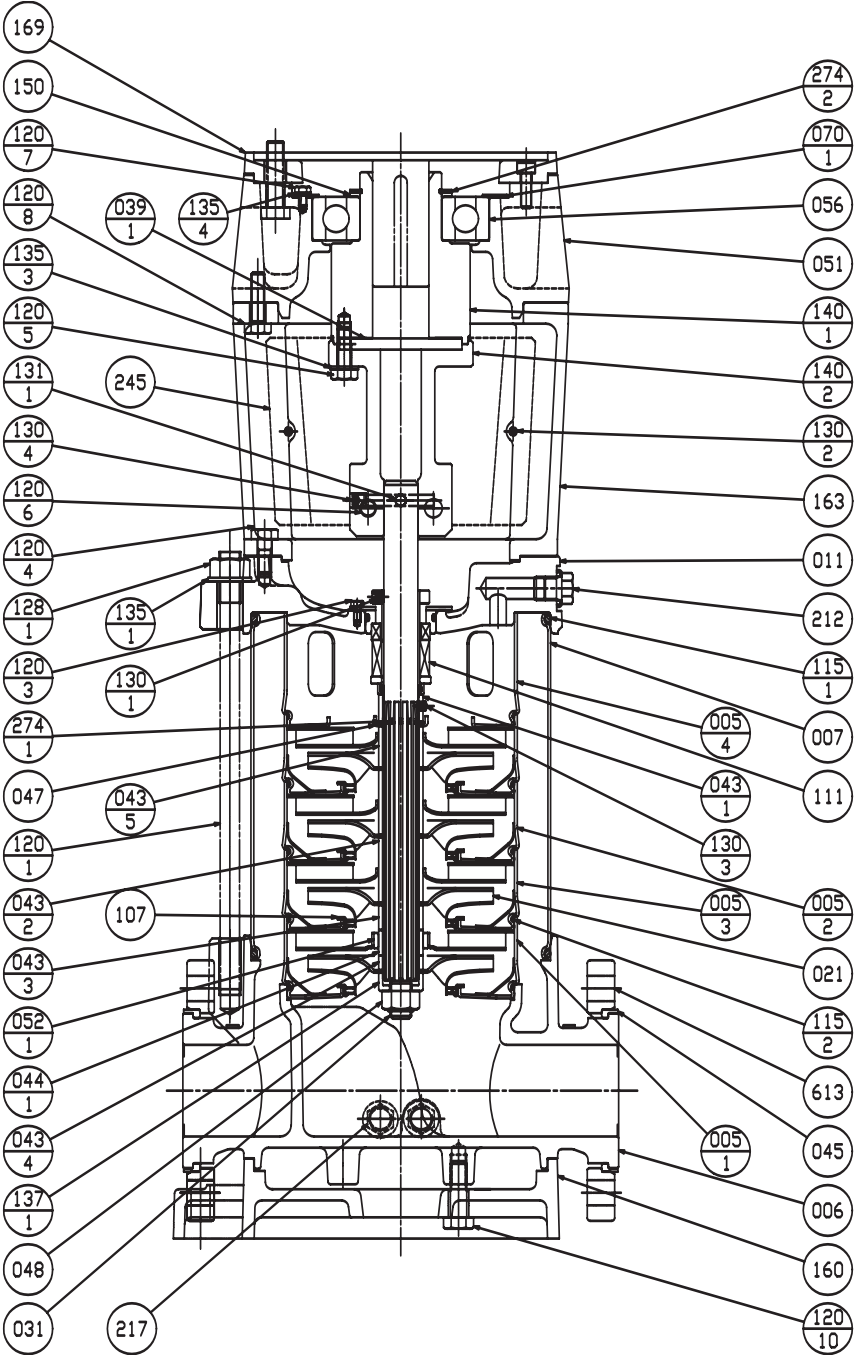
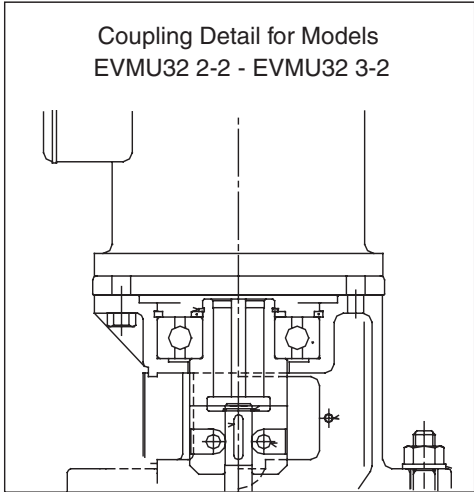
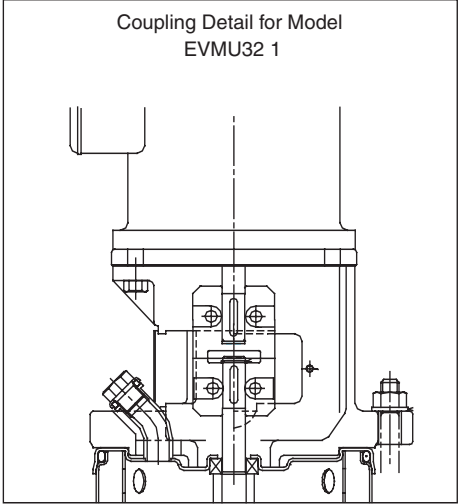

Refer to page 841 for material details.

(For reference only. See pricing for part availability.)

Model EVMUG / EVMUL

EBARA Stainless Steel Vertical Multistage

Sectional View – part reference

Model EVMUG32
EVMUL32

NO.	PART NAME	MATERIAL	
		EVMUG	EVMUL
005-1	Stage casing (suction)	AISI304	AISI316
005-2	Stage casing	AISI304	AISI316
005-3	Stage casing (bearing)	AISI304	AISI316
005-4	Stage casing (Top)	AISI304	AISI316
006	Bottom casing	Cast iron EN-GJL-250	Cast AISI316 (G-X6CrNiMo18 0)
007	Outer sleeve	AISI304	AISI316
011	Casing cover	Cast iron EN-GJS-400-15	Cast iron EN-GJS-400-15+AISI304
021	Impeller	AISI304	AISI316
031	Shaft	AISI316	
039-1	Key (coupling)	C45	
043-1	Shaft sleeve (mechanical seal)	AISI304	AISI316
043-2	Shaft sleeve (stage)	AISI304	AISI316
043-3	Shaft sleeve (bearing/upper)	AISI304	AISI316
043-4	Shaft sleeve (bearing/lower)	AISI304	AISI316
043-5	Shaft sleeve (top)	AISI304	AISI316
044-1	Bearing sleeve (stage)	Tungsten carbide	
045	Adjusting ring	C40	
047	Split ring retainer	AISI304	AISI316
048	Friction nut	AISI304	AISI316
051	Bearing housing	Cast iron EN-GJL-200	
052-1	Bearing (stage)	Tungsten carbide	
056	Ball bearing	-	
070-1	Bearing holder	AISI304	
107	Wear ring	AISI316+PTFE	
111	Mechanical seal Cartridge ass'y	SiC/Carbon/FPM/316	
115-1	O-ring (outer)	FPM	
115-2	O-ring (stage)	FPM	
120-1	Tie-rod bolt	Zincate steel with 6.8 strength class ISO 898/1	
120-3	Bolt (mechanical seal)	Stainless steel A2-70 ISO3506	
120-4	Bolt (casing cover)	Stainless steel A2-70 ISO3506	
120-5	Bolt (coupling M-side)	Zincate steel with 8.8 strength class ISO 898/1	
120-6	Bolt (coupling P-side)	Zincate steel with 8.8 strength class ISO 898/1	
120-7	Bolt (bearing)	Zincate steel with 8.8 strength class ISO 898/1	
120-8	Bolt (bearing housing)	Zincate steel with 8.8 strength class ISO 898/1	
120-10	Bolt (base plate)	Zincate steel with 8.8 strength class ISO 898/1	
128-1	Nut (tie-rod bolt)	Zincate steel with 6S strength class ISO 898/2	
130-1	Screw (mechanical seal)	Stainless steel A2-70 ISO3506	
130-2	Screw (coupling guard)	Stainless steel A2-70 ISO3506	
130-3	Screw (mechanical seal)	Stainless steel A2-70 ISO3506	
130-4	Screw (coupling pin)	Strength class 45H ISO898/5	
131-1	Pin (shaft)	CF35SMnPb10	
135-1	Washer (tie-rod bolt)	Zincate steel	
135-3	Spring washer (coupling bolt M-side)	Zincate steel	
135-4	Spring washer (bearing)	Zincate steel	
137-1	Shaft end sleeve	AISI304	AISI316
140-1	Coupling upper half	Steel (36SMnPb14)	
140-2	Coupling lower half	Steel (36SMnPb14)	
150	Spacer (coupling)	C45	
160	Base plate	Cast iron EN-GJL-200	
163	Motor stool	Cast iron EN-GJL-200	
169	Motor liner	Cast iron EN-GJL-200	
212	Vent plug (with seal ring)	AISI304/FPM	AISI316/FPM
217	Plug (with seal ring)	AISI304/FPM	AISI316/FPM
245	Coupling guard	AISI304	
274-1	C-ring (top)	AISI304	AISI316
274-2	C-ring (coupling)	Carbon tool steel (TC80)	
613	Pump flange	C40	

(For reference only. See pricing for part availability.)



Model EVMUG / EVMUL
Sectional View

EBARA Stainless Steel Vertical Multistage

Models EVMUG45
EVMUG64
EVMUL45
EVMUL64

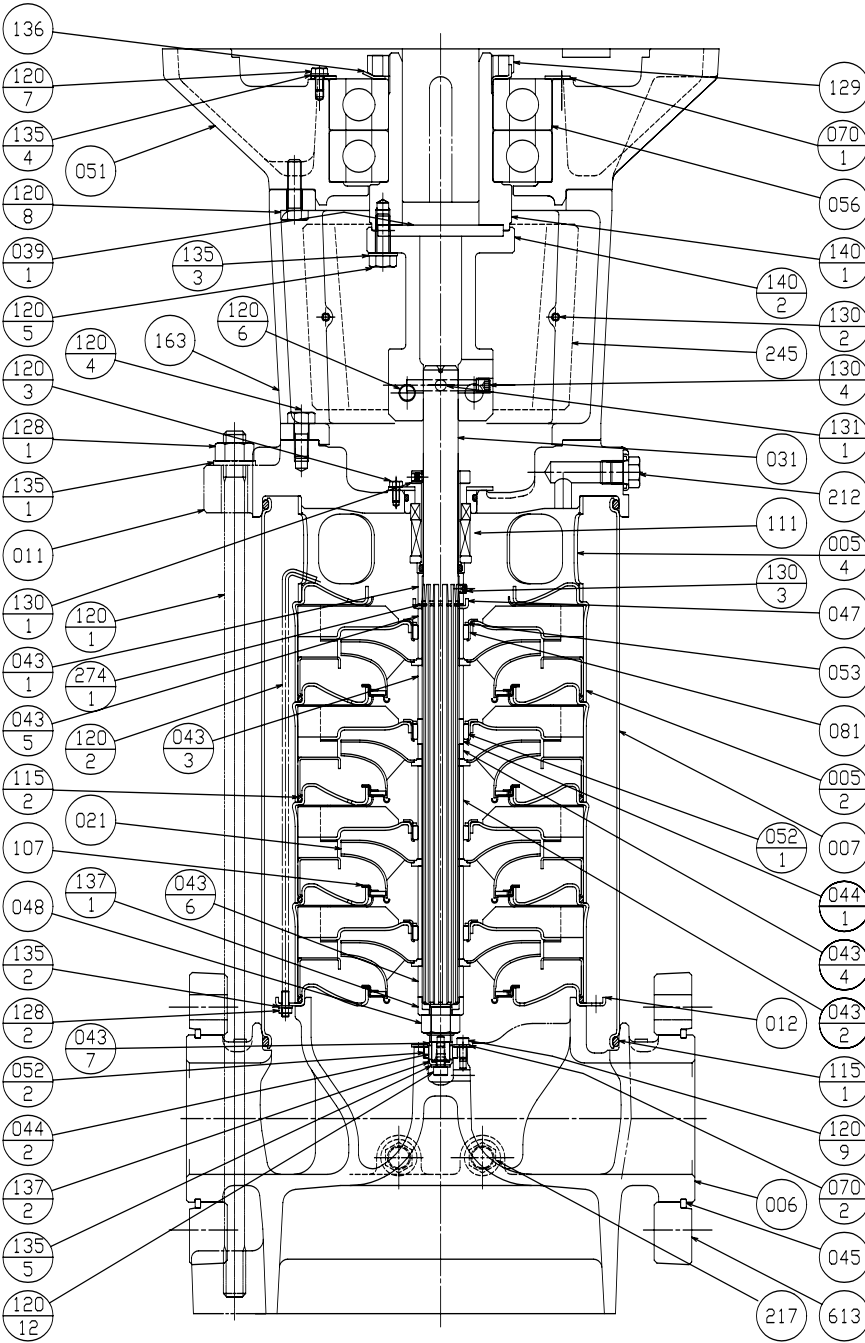
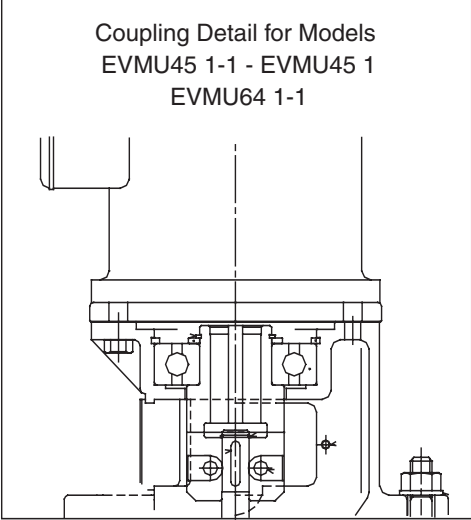

Refer to page 843 for material details.

(For reference only. See pricing for part availability.)

Model EVMUG / EVMUL

EBARA Stainless Steel Vertical Multistage

Sectional View – part reference

(See pricing for part availability.)

Model EVMUG45 EVMUG64 EVMUL45 EVMUL64

NO.	PART NAME	MATERIAL	
		EVMUG	EVMUL
005-2	Stage casing	AISI304	AISI316
005-4	Top casing	AISI304	AISI316
006	Bottom casing	16bar:Cast iron EN-GJL-250	Cast AISI316 (G-X6CrNiMo18 0)
		25bar:Cast iron EN-GJS-400-15	
007	Outer sleeve	AISI304	AISI316
011	Casing cover	Cast iron EN-GJS-400-15	Cast iron EN-GJS-400-15+AISI316
012	Suction cover	AISI304	AISI316
021	Impeller	AISI304	AISI316
031	Shaft	AISI316	
039-1	Key (coupling)	C45	
043-1	Shaft sleeve (mechanical seal)	AISI304	AISI316
043-2	Shaft sleeve (stage)	AISI304	AISI316
043-3	Shaft sleeve (bearing/upper)	AISI304	AISI316
043-4	Shaft sleeve (bearing/lower)	AISI304	AISI316
043-5	Shaft sleeve (top)	AISI304	AISI316
043-6	Shaft sleeve (suction)	AISI304	AISI316
043-7	Shaft sleeve (bottom bearing)	AISI304	AISI316
044-1	Bearing sleeve (stage)	Tungsten carbide	
044-2	Bearing sleeve (bottom bearing)	Tungsten carbide	
045	Adjusting ring	C40	
047	Split ring retainer	AISI304	AISI316
048	Friction nut	AISI304	AISI316
051	Bearing housing	Cast iron EN-GJL-200	
052-1	Bearing (stage)	Tungsten carbide	
052-2	Bearing (bottom)	Tungsten carbide	
053	Bush holder	AISI304	AISI316
056	Ball bearing	-	
070-1	Bearing holder	AISI304	
070-2	Bearing holder (bottom bearing)	AISI304	AISI316
081	Bush	PTFE(ally)	
107	Wear ring	AISI316+PTFE	
111	Mechanical seal Cartridge assy	SiC/Carbon/FPM/316	
115-1	O-ring (outer)	FPM	
115-2	O-ring (stage)	FPM	
120-1	Tie-rod bolt	Zincate steel with 6.8 strength class ISO 898/1	
120-2	Stack bolt	AISI304	AISI316
120-3	Bolt (mechanical seal)	Stainless steel A2-70 ISO3506	
120-4	Bolt (casing cover)	Stainless steel A2-70 ISO3506	
120-5	Bolt (coupling M-side)	Zincate steel with 8.8 strength class ISO 898/1	
120-6	Bolt (coupling P-side)	Zincate steel with 8.8 strength class ISO 898/1	
120-7	Bolt (bearing)	Zincate steel with 8.8 strength class ISO 898/1	
120-8	Bolt (bearing housing)	Zincate steel with 8.8 strength class ISO 898/1	
120-9	Bolt (bottom bearing)	Stainless steel A2-70 ISO3506	
120-12	Bolt (shaft end)	Stainless steel A2-70 ISO3506	
128-1	Nut (tie-rod bolt)	Zincate steel with 6S strength class ISO 898/2	
128-2	Nut (Stack bolt)	AISI304	
129	Bearing nut (coupling)	Carbon steel	
130-1	Screw (mechanical seal)	Stainless steel A2-70 ISO3506	
130-2	Screw (coupling guard)	Stainless steel A2-70 ISO3506	
130-3	Screw (mechanical seal)	Stainless steel A2-70 ISO3506	
130-4	Screw (coupling pin)	Strength class 45H ISO898/5	
131-1	Pin (shaft)	CF35SMnPb10	
135-1	Washer (tie-rod bolt)	Zincate steel	
135-2	Spring washer (Stack bolt)	AISI304	AISI316
135-3	Spring washer (coupling bolt M-side)	Zincate steel	
135-4	Spring washer (bearing)	Zincate steel	
135-5	Spring washer (shaft end)	AISI304	AISI316
136	Bearing washer (coupling)	Carbon steel	
137-1	Shaft end sleeve	AISI304	AISI316
137-2	Shaft end sleeve	AISI304	AISI316
140-1	Coupling upper half	Steel (36SMnPb14)	
140-2	Coupling lower half	Steel (36SMnPb14)	
163	Motor stool	Cast iron EN-GJL-200	
212	Vent plug (with seal ring)	AISI304/FPM	AISI316/FPM
217	Plug (with seal ring)	AISI304/FPM	AISI316/FPM
245	Coupling guard	AISI304	
274-1	C-ring (top)	AISI304	AISI316
613	Pump flange	C40	

(For reference only. See pricing for part availability.)

