

Contents

Model

- 50DVSHU6.4
- 50DVSHU6.75
- 50DVSHU61.5
- 80DVSHU6.75
- 80DVSHU61.5
- 80DVSU62.2
- 80DVSHU62.2
- 80DVSU63.7
- 80DVSHU63.7

Section	Page
Specifications	1-173
Selection Chart	1-173.1, 174.1
Performance Curves	1-177
Outline Drawings	1-181
Sectional View	1-187
QDC Information	1-189
Technical Information	1-195
material specification	
impeller description	
motor protection	
cable entry	
paint specifications	
mechanical seal	
general	
Motor Data	1-212.1
motor electrical specifications	
cable data	
wiring diagrams	
motor electrical data	

Model Designation

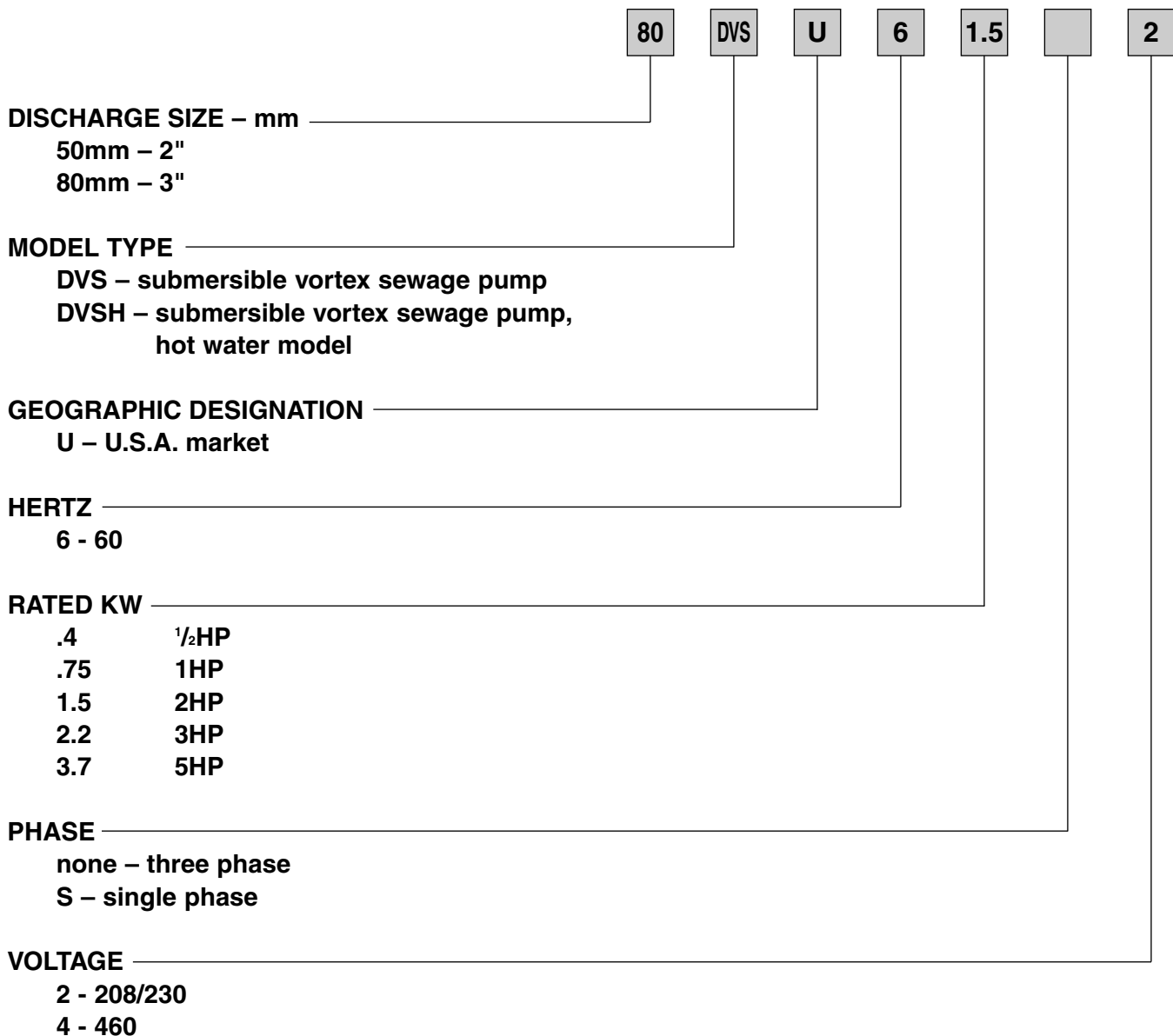

Specification

Model DVSU Specifications

	Standard	Optional
Size	3 inch	
Range of HP Range of Performance	3 HP to 5 HP Capacity 29 to 240 GPM Head 20 to 80 feet	
Limitation Maximum Water Temperature	122°F (50°C)	
Synchronous Speed	3600 RPM	
Materials Casing Impeller Shaft Motor Frame Fastener	Cast Iron Cast Iron 403 Stainless Steel Cast Iron 304 Stainless Steel	
Mechanical Seal Material – Upper Side Material – Lower Side Impeller Type Bearing Motor Three Phase Service Factor Motor Protection Submersible cable Accessories	Double Mechanical Seal Carbon/Ceramic Silicon Carbide/Silicon Carbide Recessed Semi-vortex Prelubricated Ball Bearing Air-filled, Insulation Class F 208/230, 460V 1.15 Built-in Auto Cut - overload, out of phase, single phasing protection 33 ft. Cast iron discharge elbow	66 ft. QDC System



Selection chart

Model DVSU
Three Phase

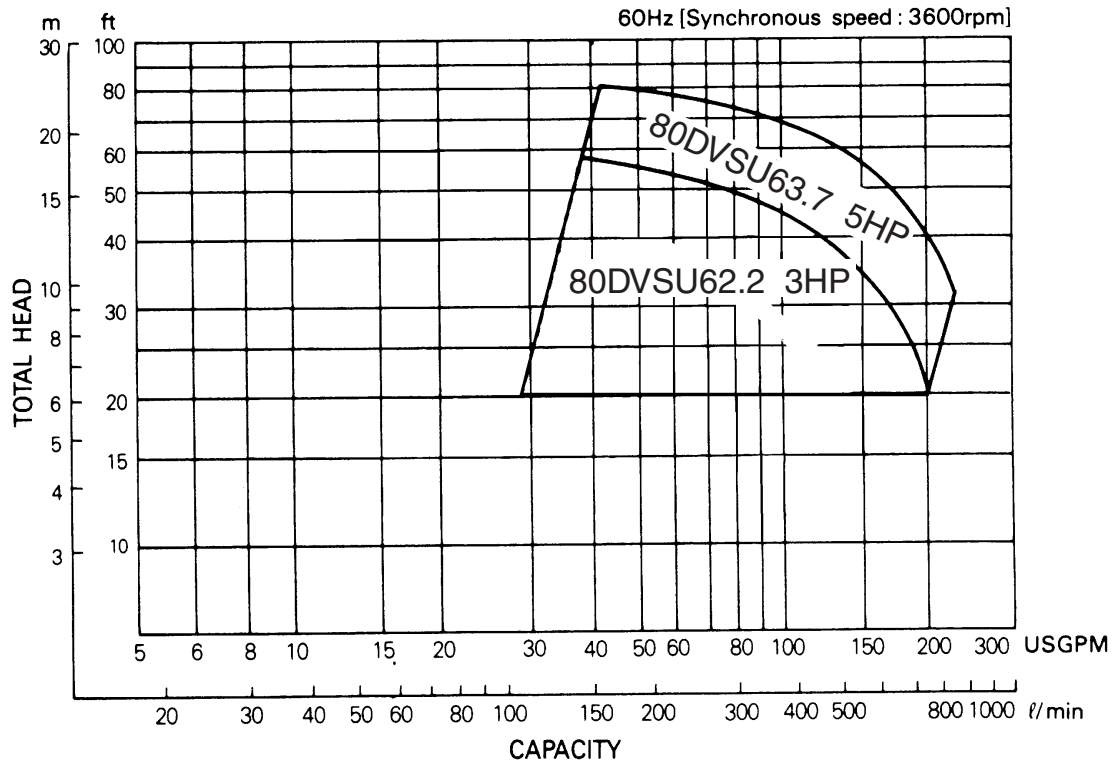

Specifications

Model DVSHU – Hot Water Pumps Specifications

	Standard	Optional
Size	2, 3 inch	
Range of HP Range of Performance	1/2 HP to 5 HP Capacity 5 to 240 GPM Head 10 to 75 feet	
Limitation Maximum Water Temperature	158°F (70°C) 1/2 , 1 HP 176°F (80°C) 2 to 5 HP 200°F (93°C) Operation is limited to 10 minutes	
Synchronous Speed	3600 RPM	
Materials Casing Impeller Shaft Motor Frame Fastener	Cast Iron Cast Iron 403 Stainless Steel Cast Iron 304 Stainless Steel	
Mechanical Seal Material – Upper Side Material – Lower Side Impeller Type Bearing Motor Three Phase Service Factor Motor Protection Submersible cable Accessories	Double Mechanical Seal Silicon Carbide/Silicon Carbide Silicon Carbide/Silicon Carbide Recessed Semi-vortex Prelubricated Ball Bearing Air-filled, Insulation Class H, F 208/230V, 460V 1.15 Built-in Overload Protection 33 ft. – 3, 5HP Cast iron companion flange with NPT thread (2", 1/2 to 2HP) Cast iron discharge elbow (3", 1 to 5HP)	66 ft. QDC System

Selection chart

Model DVSHU – Hot Water Pumps
Three Phase

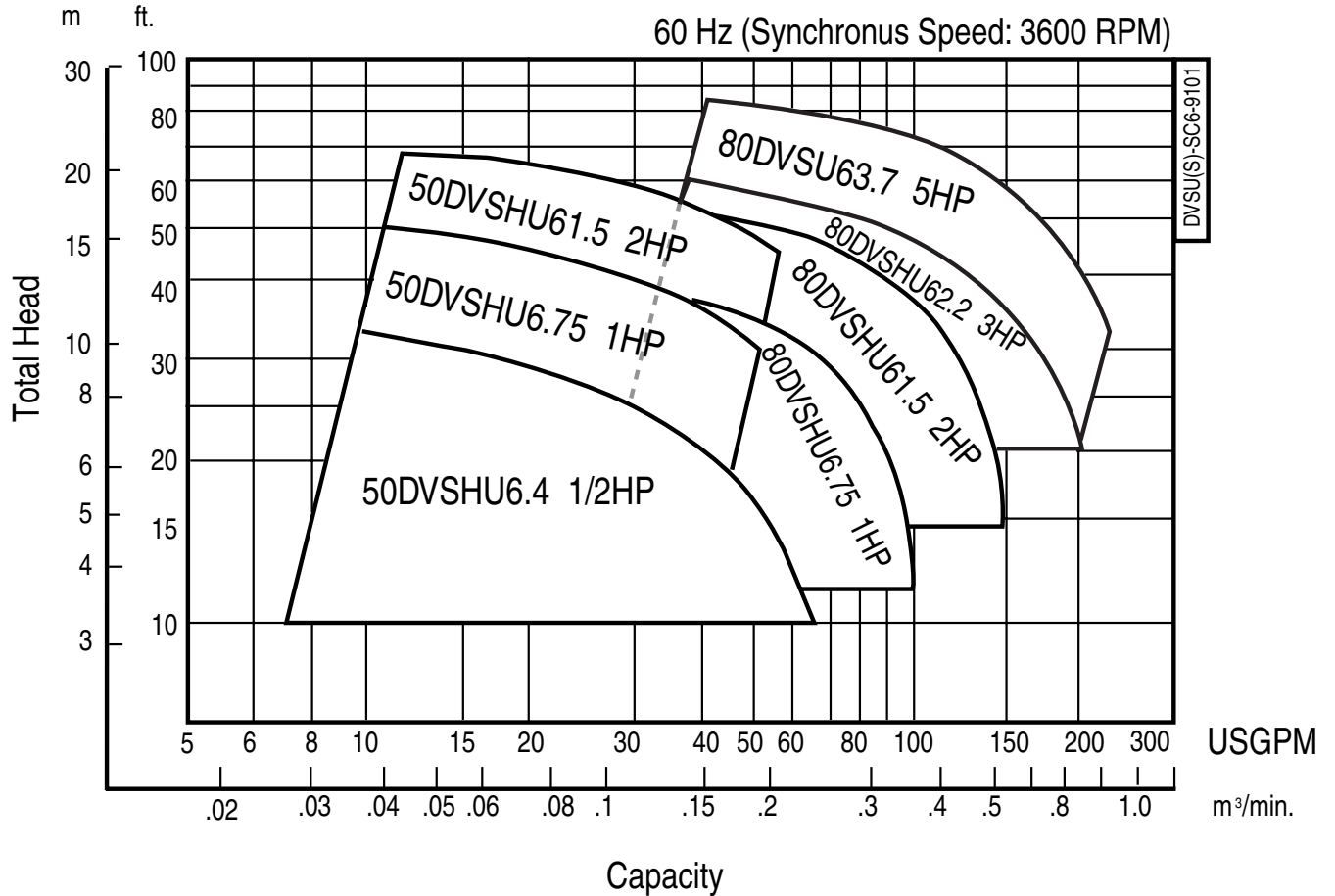

Specifications

A. General:

Provide submersible vortex sewage/drainage pumps suitable for continuous duty operation underwater without loss of watertight integrity to a depth of 65 feet. If mounted on a guide rail system, design shall be such that the pump will be automatically connected to the discharge piping when lowered into place on the discharge connection. The pump shall be easily removable for inspection or service, requiring no bolts, nuts, or other fasteners to be disconnected, or the need for personnel to enter the wet well. The motor and pump shall be designed, manufactured, and assembled by the same manufacturer.

B. Manufacturer:

Ebara International Corporation

C. Pump Characteristics:

Pumps shall conform to the following requirements:

Number of units	
Design flow (gpm)	
Design TDH (ft)	
Minimum shut off head (ft)	
RPM	3600
Maximum HP	
Minimum efficiency at design (%)	
Minimum power factor at design (%)	
Voltage/HZ	208/230V, 460V / 60
Phase	3

D. Pump Construction:

All major parts of the pumping unit(s) including casing, impeller, motor frame and discharge elbow shall be manufactured from gray cast iron, ASTM A-48 Class 30. Castings shall have smooth surfaces devoid of blow holes or other casting irregularities. Casing design shall be centerline discharge with a large radius on the cut water to prevent clogging. Units with 2" discharge sizes shall be furnished with a female NPT connection. Units with 3" and larger discharge ports shall be furnished with a discharge elbow and 125 lb. flat face ANSI flange. All exposed bolts and nuts shall be 304 stainless steel. All mating surfaces of major components shall be machined and fitted with NBR O-rings where watertight sealing is required. Machining and fitting shall be such that sealing is accomplished by automatic compression of O-rings in two planes and O-ring contact is made on four surfaces without the requirement of specific torque limits. Internal and external surfaces are prepared to SPPC-VISI-SP-3-63 then coated with a zinc-chromate primer. The external surfaces are then coated with a chlorinated rubber paint.

Impeller design shall be a recessed, semi-vortex, multi-vane design, direct connected to the motor shaft with a slip fit, key driven, and secured with an impeller nut. The inlet edge of the impeller vanes shall be angled toward the impeller periphery so as to facilitate the release of objects that might otherwise clog the pump.

Double mechanical seals operating in an oil bath shall be provided on all units. The oil filled seal chamber shall be designed to prevent over-filling and include an anti-vortexing vane to insure proper lubrication of both seal faces. For applications under 122°F; lower face materials shall be silicon carbide, upper faces carbon vs ceramic, NBR elastomers, and 304SS hardware. Applications greater than 122°F shall include silicon carbide face materials for both upper and lower seals, and viton elastomers. Seal system shall not rely on pumping medium for lubrication.

Specifications

E. Motor Construction:

The pump motor shall be an air filled induction type with a squirrel cage rotor, shell type design, built to NEMA MG-1, Design B specifications. Stator windings shall be copper, insulated with moisture resistant Class F insulation, rated for 311°F. The stator shall be dipped and baked three times in Class F (Class H for DVSH ½, 1, and 2 HP models) varnish and heat shrunk fitted into the stator housing. Rotor bars and short circuit rings shall be manufactured of cast aluminum. Motor shaft shall be one piece 403SS AISI403 material, rotating on two permanently lubricated ball bearings designed for a minimum B-10 life of 60,000 hours. Model DVSU motors shall be designed for continuous duty pumping at a maximum sump temperature of 122°F and capable of up to 20 starts per hour. Model DVSHU motors shall be designed for up to 20 starts per hour continuous duty pumping at a maximum sump temperature of 158°F for ½ and 1 HP units, and 176°F for 2 to 5 HP units. Motor service factor shall be 1.15. Voltage and frequency tolerances shall be a maximum 10% / 5% respectively. Junction area shall include a terminal board for power connections eliminating the need for wire nuts. Motor protection shall be provided by an auto-cut device located directly over the windings to provide protection from single phasing, low voltage, phase imbalance, locked rotor, and no load or run dry conditions. Motor shall be non-overloading over the entire performance curve and be able to operate at full load intermittently while unsubmerged without damage to the unit.

Power cable jacket shall be manufactured of an oil resistant chloroprene rubber material, designed for submerged applications. Cable shall be watertight to a depth of at least 65'. Cable entry shall be composed of a one piece, vulcanized, three way mechanical sealing system with a thick molded shoulder with increasing cable diameters to resist fatigue from bending forces. The molded shoulder, acts as the primary and secondary sealing points. This system shall also prevent leakage into the motor housing due to capillary action through the insulation if the cable is damaged or cut. Units ½ to 5 HP shall utilize a metallic plate to clamp the entry system to the motor housing. Strain relief on these sizes shall be accomplished by clamping and attaching the cable with chain to the motor housing.

F. Guide Rail system:

Design shall include two (2) 304SS schedule 40 guide rails sized to mount directly to the quick discharge connector, QDC, at the floor of the wetwell and to a guide rail bracket at the top of the wetwell below the hatch opening, (refer to project drawings).

Units below one (1) HP shall utilize a single angle iron rail in lieu of two (2) Guide pipes. Intermediate guide brackets shall be supplied for rail lengths over 20 feet.

Guide rails are not part of the pump package and shall be supplied by others.

The QDC shall be manufactured of cast iron, A48 Class 30. It shall be designed to adequately support the guide rails, discharge piping, and pumping unit under both static and dynamic loading conditions with support legs that are suitable for anchoring it to the wetwell floor. The face of the inlet QDC flange shall be perpendicular to the floor of the wetwell.

The pump design shall include an integral self-aligning sliding bracket. Sealing of the pumping unit to the QDC shall be accomplished by a single, linear, downward motion of the pump. The entire weight of the pump unit shall be guided to and wedged tightly against the inlet flange of the QDC, making metal to metal contact with the pump discharge forming a seal without the use of bolts, gaskets or O-rings.

Lifting chain, either galvanized or stainless steel, suitable for removing and installing the pump unit shall be provided.



Performance Curves

Project: _____ GPM: _____ TDH: _____ EFF: _____ HP: _____ Chk'd: _____ Date: _____

50DVSH6.4 (1/2HP) Synchronous Speed: 3600 RPM

2 inch Discharge

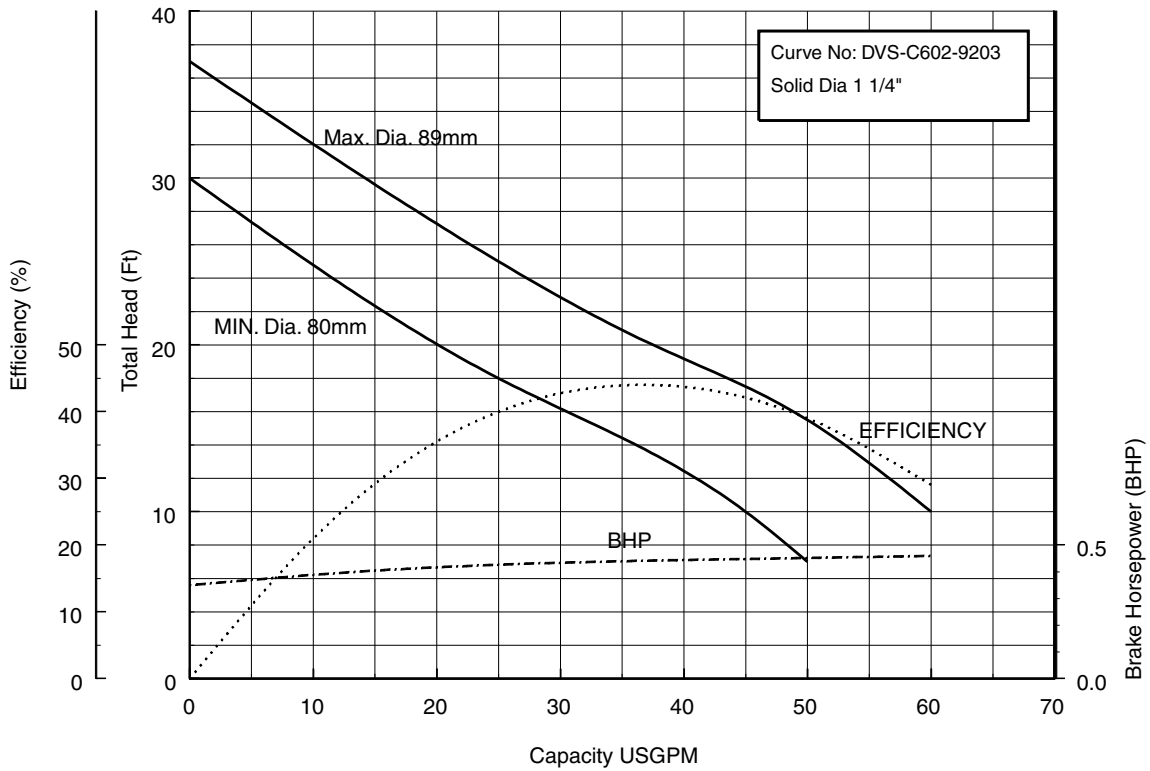

50DVSH6.75 (1HP) Synchronous Speed: 3600 RPM

2 inch Discharge

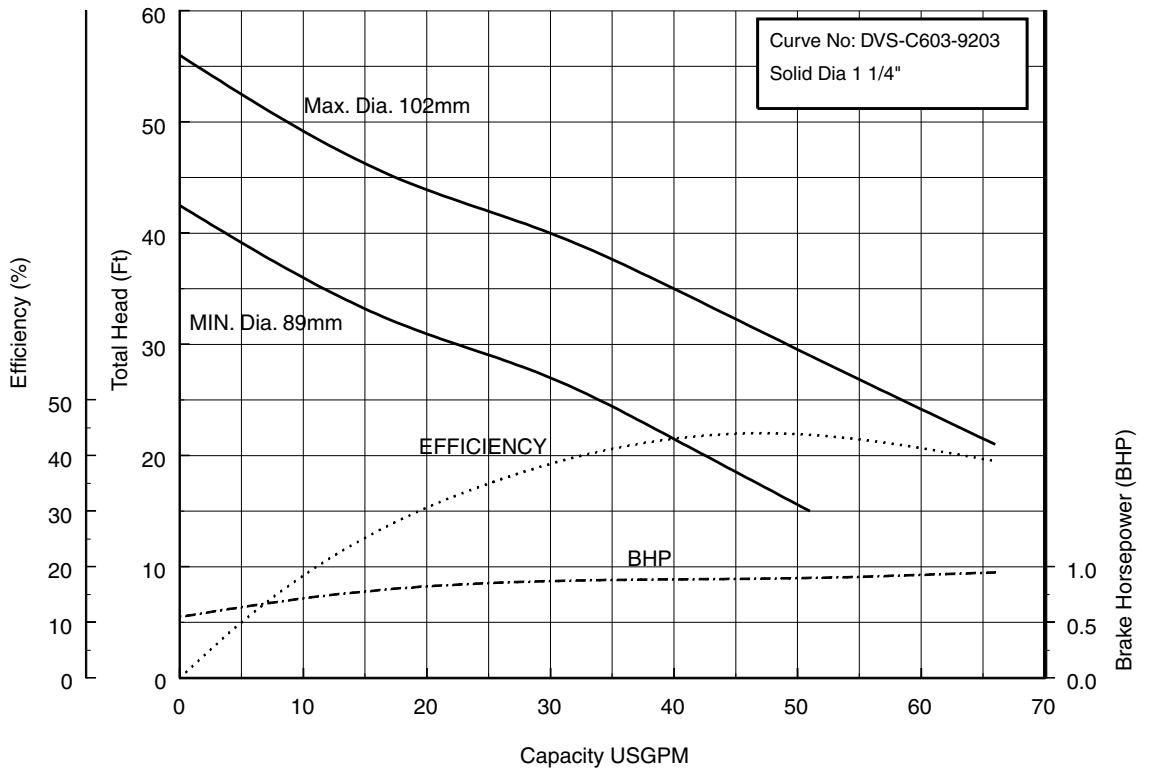

Performance Curves

Project: _____ GPM: _____ TDH: _____ EFF: _____ HP: _____ Chk'd: _____ Date: _____

50DVSH61.5 (2HP) Synchronous Speed: 3600 RPM

2 inch Discharge

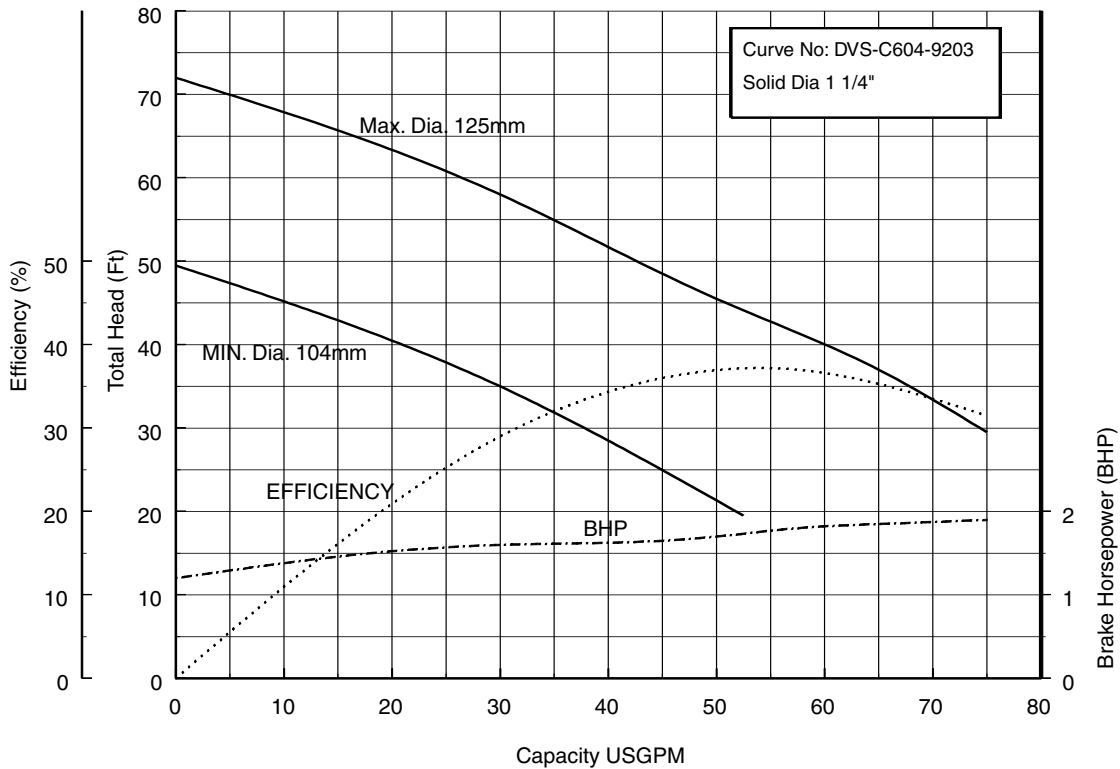

80DVSH6.75 (1HP) Synchronous Speed: 3600 RPM

3 inch Discharge

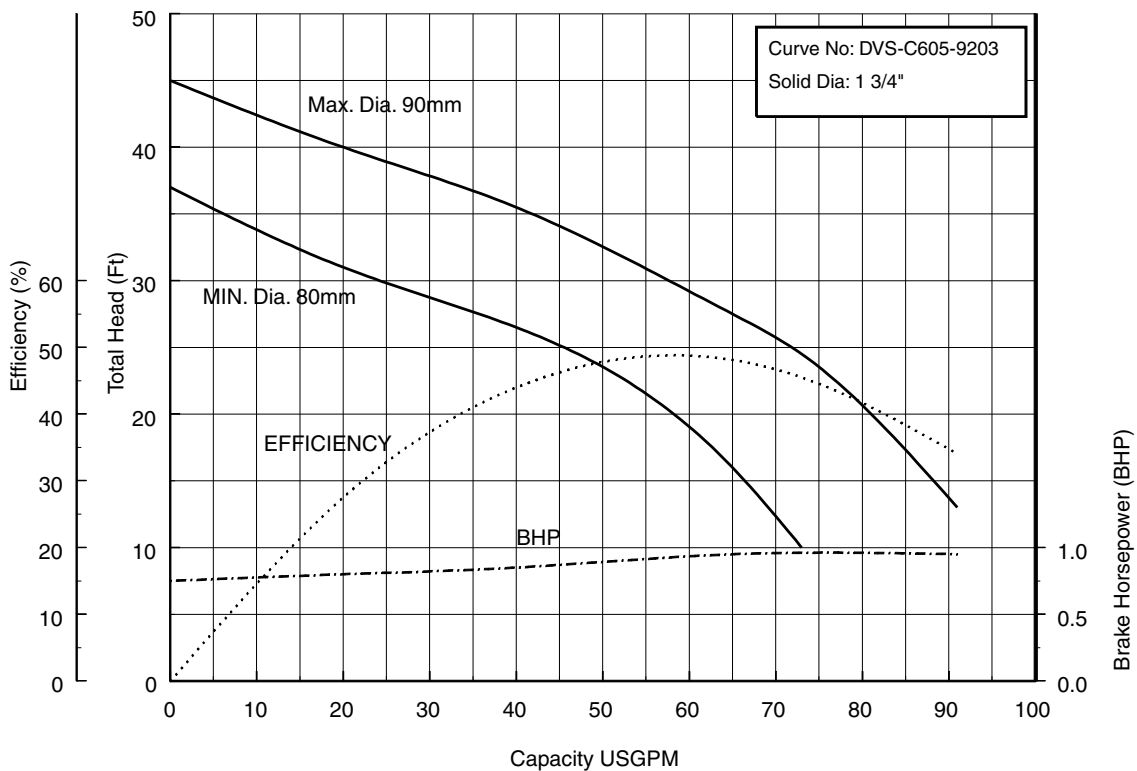

Performance Curves

Project: _____ GPM: _____ TDH: _____ EFF: _____ HP: _____ Chk'd: _____ Date: _____

80DVSH61.5 (2HP) Synchronous Speed: 3600 RPM

3 inch Discharge

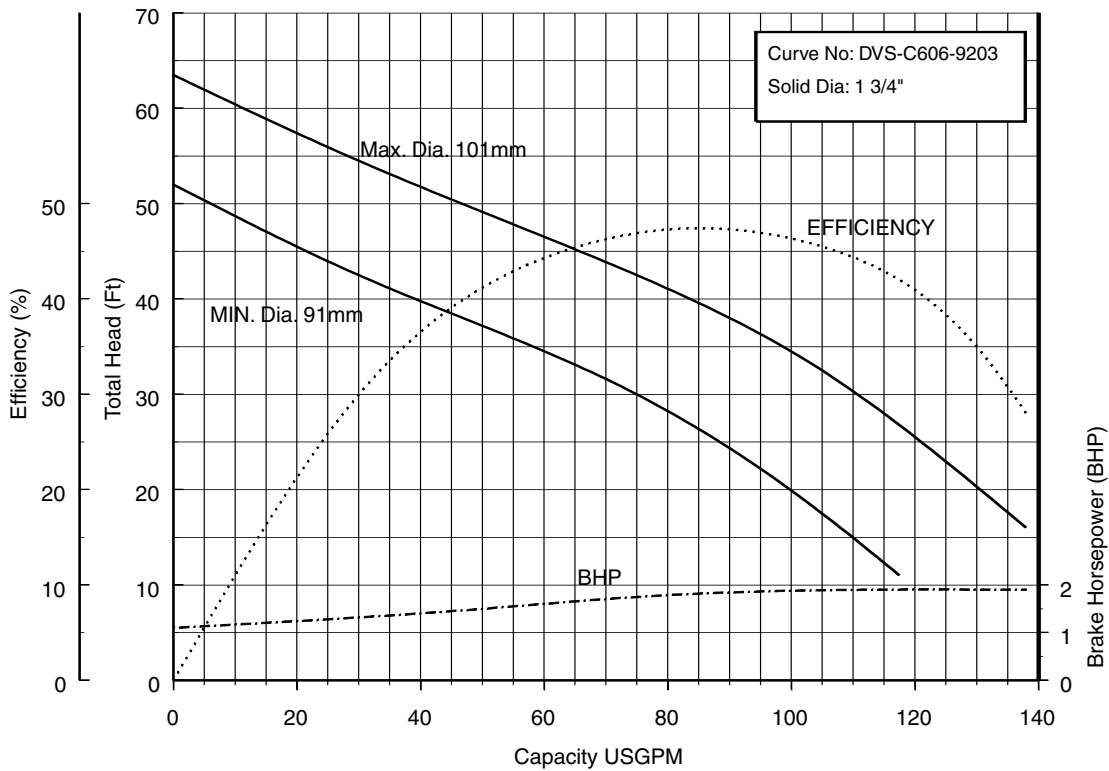

80DVS62.2 80DVSH62.2 (3HP) Synchronous Speed: 3600 RPM

3 inch Discharge

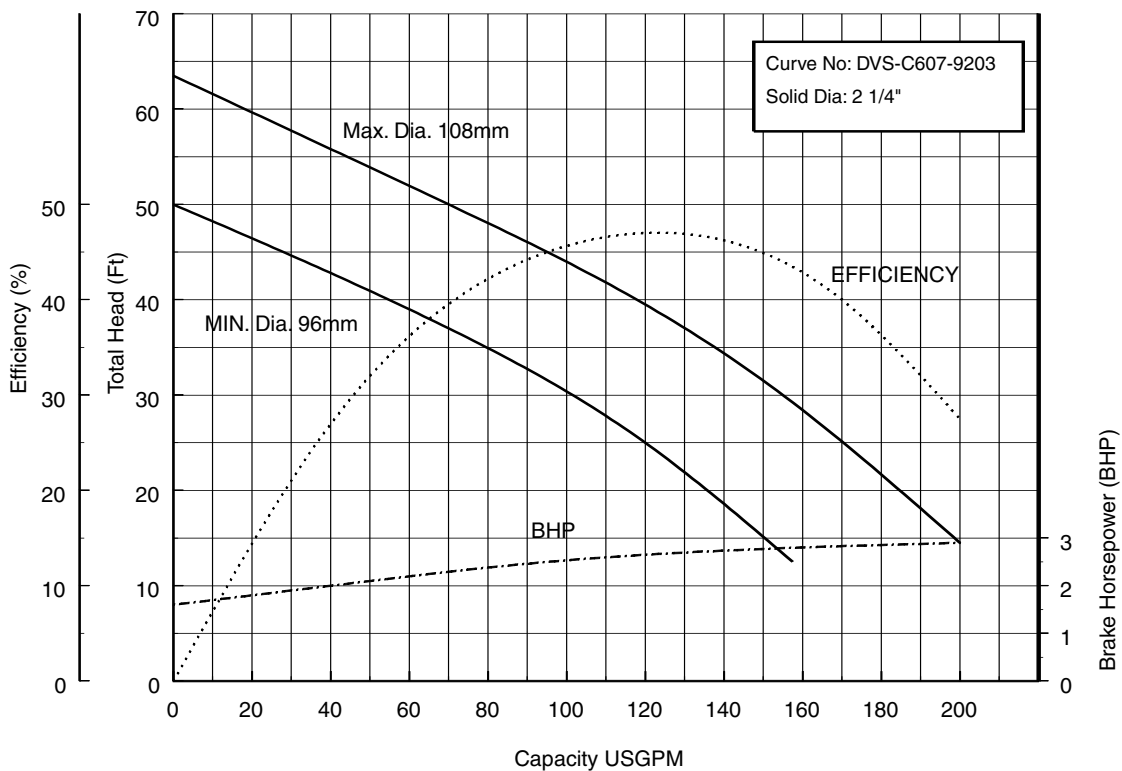

Performance Curves

Project: _____ GPM: _____ TDH: _____ EFF: _____ HP: _____ Chk'd: _____ Date: _____

80DVS63.7 80DVSH63.7 (5HP) Synchronous Speed: 3600 RPM 3 inch Discharge

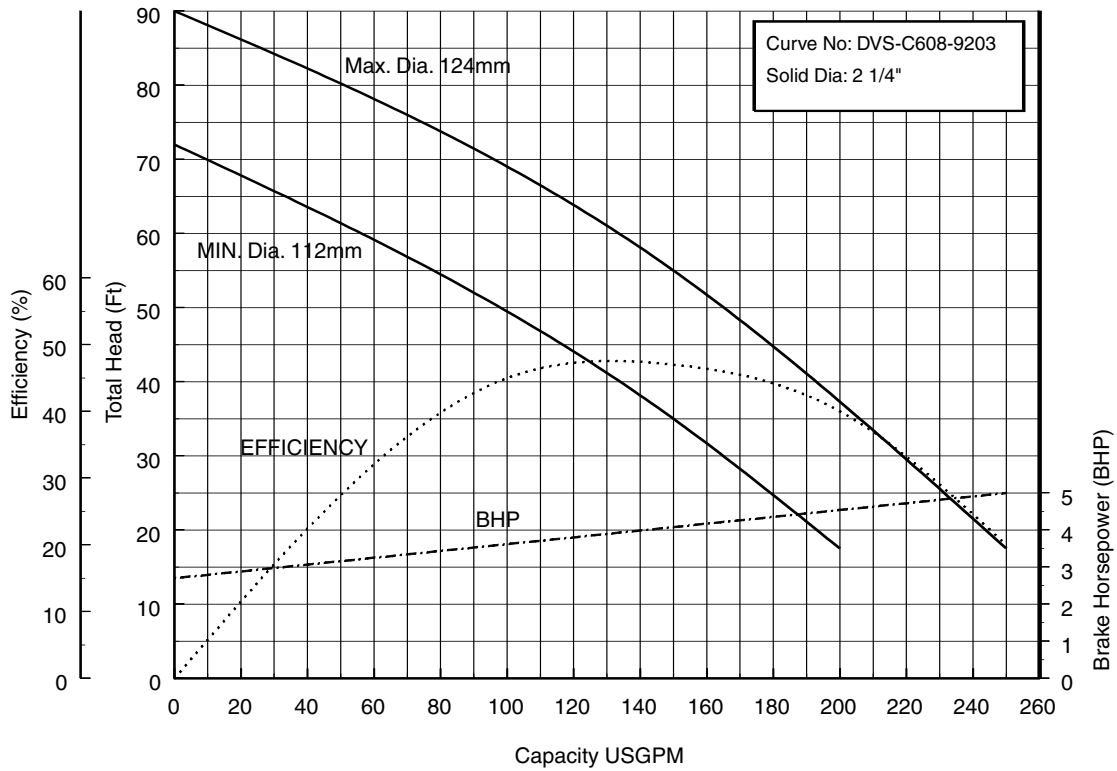

Dimensions

Project: _____ Model: _____ Chk'd: _____ Date: _____

Model DVSHU
 Hot Water Pumps
 50DVSHU, 1/2 to 2HP

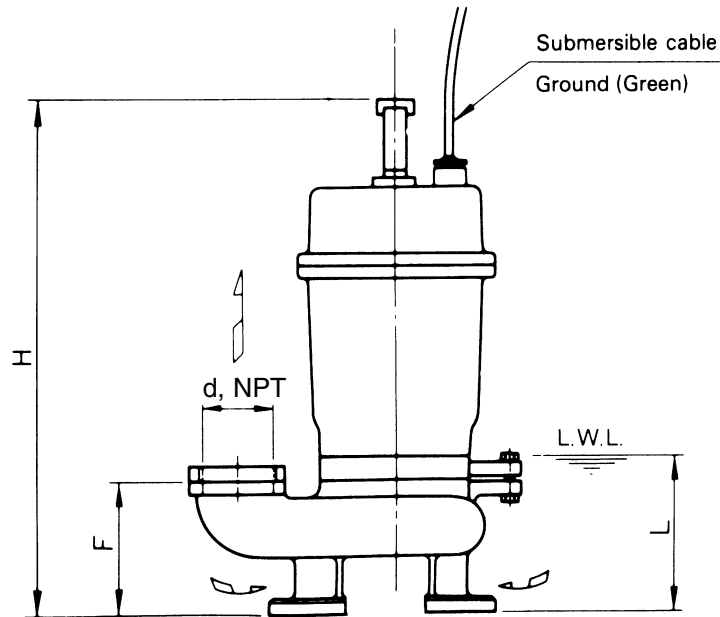
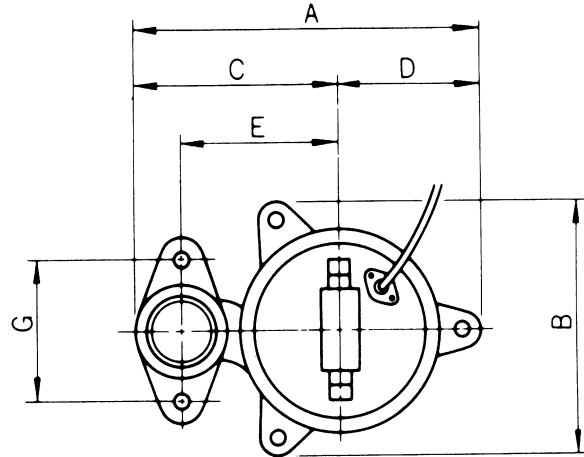

Dimensions: inch

PHASE	SIZE _d	MODEL	OUTPUT		PUMP & MOTOR									WEIGHT Lb
			kW	HP	A	B	C	D	E	F	G	H	L	
THREE	2	50DVSHU6.4	0.4	1/2	9 ⁷ / ₁₆	6 ⁵ / ₁₆	5 ¹³ / ₁₆	3 ⁹ / ₁₆	4 ⁵ / ₁₆	3 ¹ / ₄	3 ³ / ₄	15 ⁷ / ₁₆	4 ¹ / ₈	31
		50DVSHU6.75	0.75	1	9 ¹³ / ₁₆	6 ³ / ₄	6 ⁷ / ₁₆	3 ³ / ₈	4 ¹⁵ / ₁₆	3 ¹ / ₄	3 ³ / ₄	15 ⁵ / ₈	4 ¹ / ₈	42
		50DVSHU61.5	1.5	2	9 ¹³ / ₁₆	6 ³ / ₄	6 ⁷ / ₁₆	3 ³ / ₈	4 ¹⁵ / ₁₆	3 ¹ / ₄	3 ³ / ₄	17 ⁵ / ₁₆	4 ¹ / ₈	60

Dimensions: mm

PHASE	SIZE _d	MODEL	OUTPUT		PUMP & MOTOR									WEIGHT kg
			kW	HP	A	B	C	D	E	F	G	H	L	
THREE	50	50DVSHU6.4	0.4	1/2	239	160	148	91	110	83	96	392	105	14
		50DVSHU6.75	0.75	1	249	171	163	86	125	83	96	391	105	19
		50DVSHU61.5	1.5	2	249	171	163	86	125	83	96	440	105	27

Dimensions

Project: _____ Model: _____ Chk'd: _____ Date: _____

Model DVSHU
 Hot Water Pumps
 80DVSHU, 1 to 5 HP

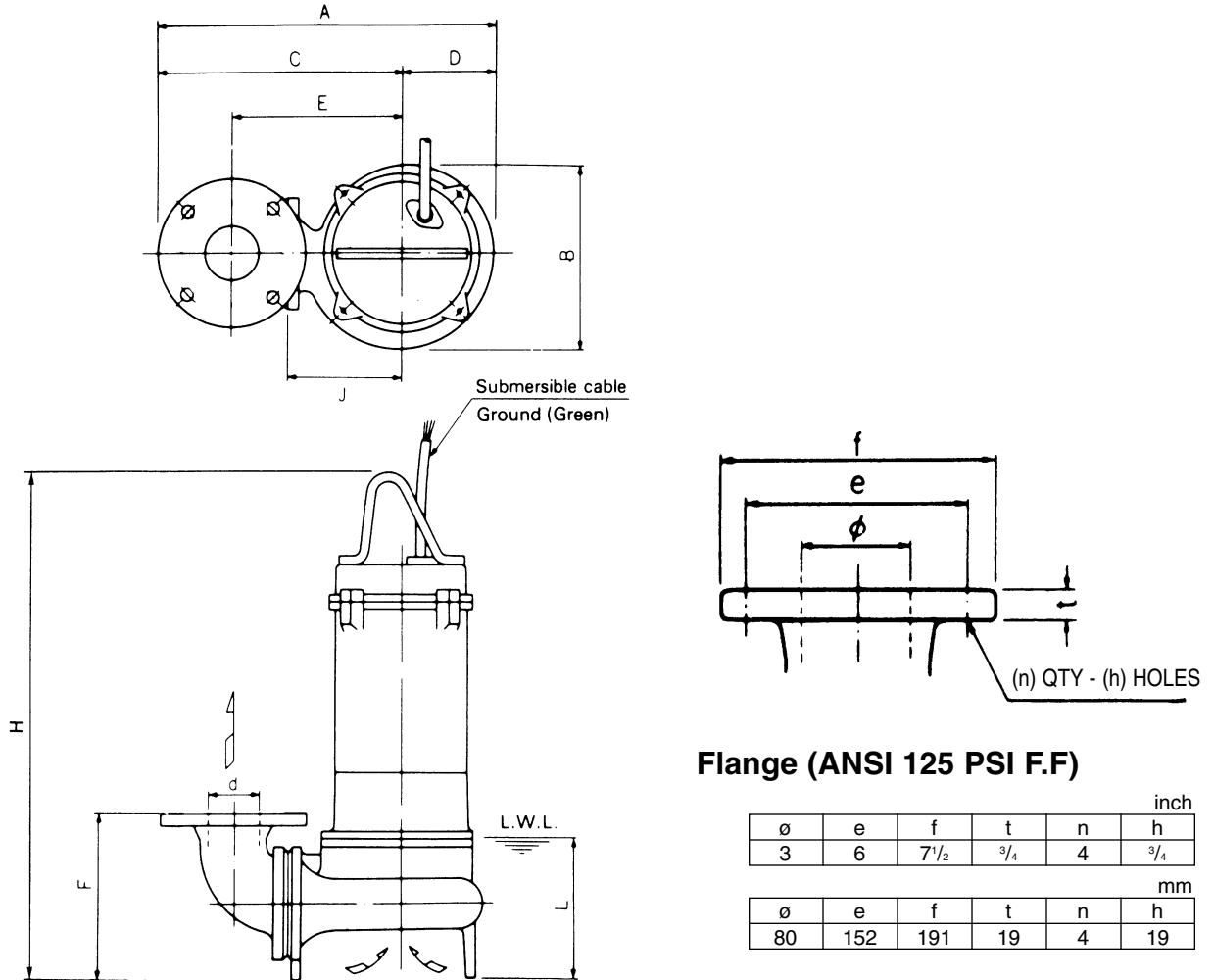

Dimensions: inch

PHASE	SIZE d	MODEL	OUTPUT		PUMP & MOTOR									WEIGHT Lb
			kW	HP	A	B	C	D	E	F	H	J	L	
THREE	3	80DVSHU6.75	0.75	1	16 ³ / ₁₆	8	12 ⁵ / ₁₆	3 ⁷ / ₈	8 ¹¹ / ₁₆	7 ³ / ₁₆	18 ³ / ₈	5 ¹ / ₁₆	4 ¹⁵ / ₁₆	57
		80DVSHU61.5	1.5	2	16 ³ / ₁₆	8	12 ⁵ / ₁₆	3 ⁷ / ₈	8 ¹¹ / ₁₆	7 ³ / ₁₆	20 ⁷ / ₁₆	5 ¹ / ₁₆	4 ¹⁵ / ₁₆	77
		80DVSHU62.2	2.2	3	17 ³ / ₈	12 ¹⁵ / ₁₆	12 ¹⁵ / ₁₆	4 ¹ / ₂	9 ¹ / ₄	8 ¹ / ₈	25 ⁷ / ₈	6 ⁵ / ₁₆	6 ¹ / ₈	112
		80DVSHU63.7	3.7	5	17 ³ / ₈	12 ¹⁵ / ₁₆	12 ¹⁵ / ₁₆	4 ¹ / ₂	9 ¹ / ₄	8 ¹ / ₈	27 ³ / ₁₆	6 ⁵ / ₁₆	6 ¹ / ₈	132

Dimensions: mm

PHASE	SIZE d	MODEL	OUTPUT		PUMP & MOTOR									WEIGHT kg
			kW	HP	A	B	C	D	E	F	H	J	L	
THREE	80	80DVSHU6.75	0.75	1	411	203	313	98	220	183	467	145	125	26
		80DVSHU61.5	1.5	2	411	203	313	98	220	183	519	145	125	35
		80DVSHU62.2	2.2	3	442	328	328	114	235	206	658	160	155	51
		80DVSHU63.7	3.7	5	442	328	328	114	235	206	691	160	155	60

Dimensions

Project: _____ Model: _____ Chk'd: _____ Date: _____

Model DVSU
80DVSU, 3 to 5 HP

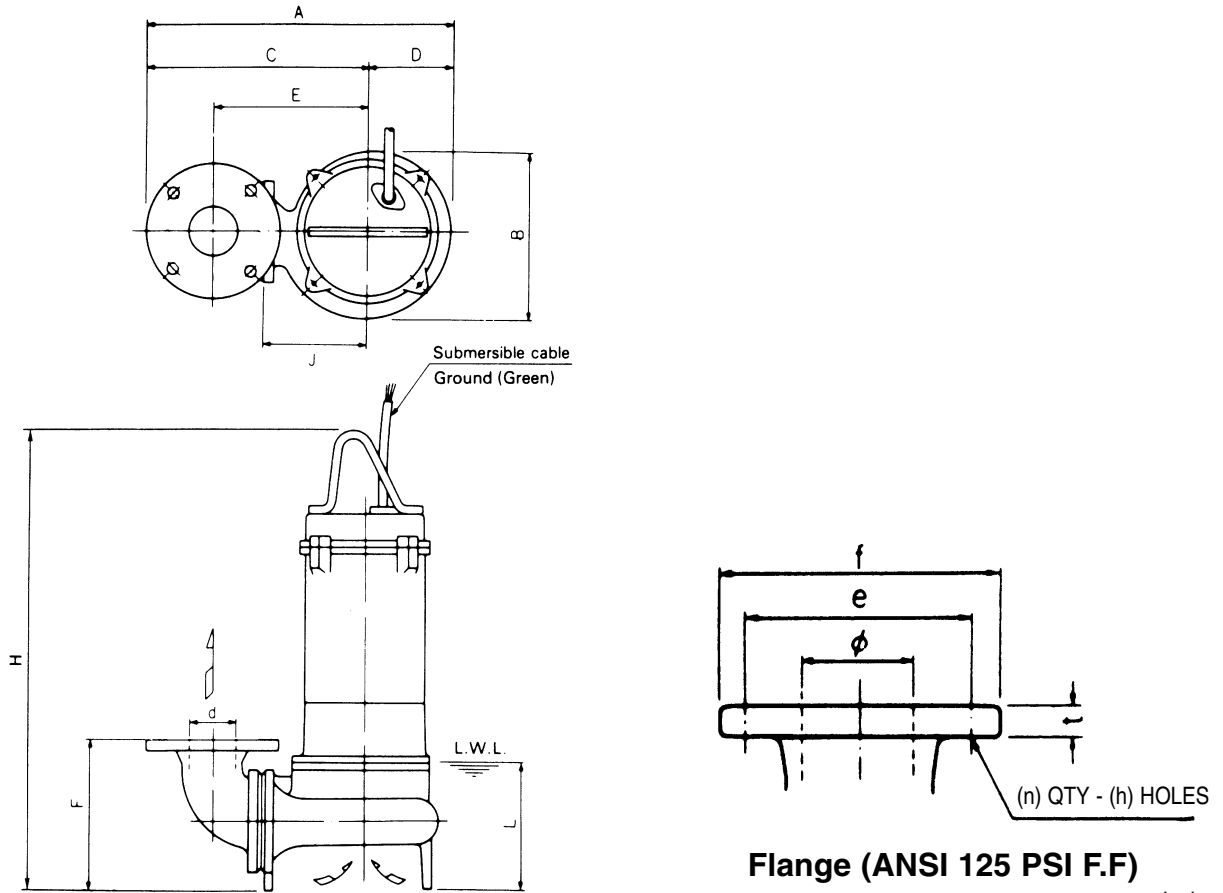

Flange (ANSI 125 PSI F.F)

inch					
ø	e	f	t	n	h
3	6	7 1/2	3/4	4	3/4
mm					
ø	e	f	t	n	h
80	152	191	19	4	19

Dimensions: inch

PHASE	SIZE d	MODEL	OUTPUT		PUMP & MOTOR									WEIGHT Lb
			kW	HP	A	B	C	D	E	F	H	J	L	
THREE	3	80DVSU62.2	2.2	3	17 3/8	12 15/16	12 15/16	4 1/2	9 1/4	8 1/8	28 5/8	6 5/16	6 1/8	112
		80DVSU63.7	3.7	5	17 3/8	12 15/16	12 15/16	4 1/2	9 1/4	8 1/8	28 5/8	6 5/16	6 1/8	132

Dimensions: mm

PHASE	SIZE d	MODEL	OUTPUT		PUMP & MOTOR									WEIGHT kg
			kW	HP	A	B	C	D	E	F	H	J	L	
THREE	80	80DVSU62.2	2.2	3	442	328	328	114	235	206	727	160	155	51
		80DVSU63.7	3.7	5	442	328	328	114	235	206	727	160	155	60

Dimensions

Project: _____ Model: _____ Chk'd: _____ Date: _____

Model DVSHU

Hot Water Pumps with Quick Discharge Connector
50DVSHU, 1/2 to 5 HP

Minimum dimensions of manhole
15 3/4 (400)

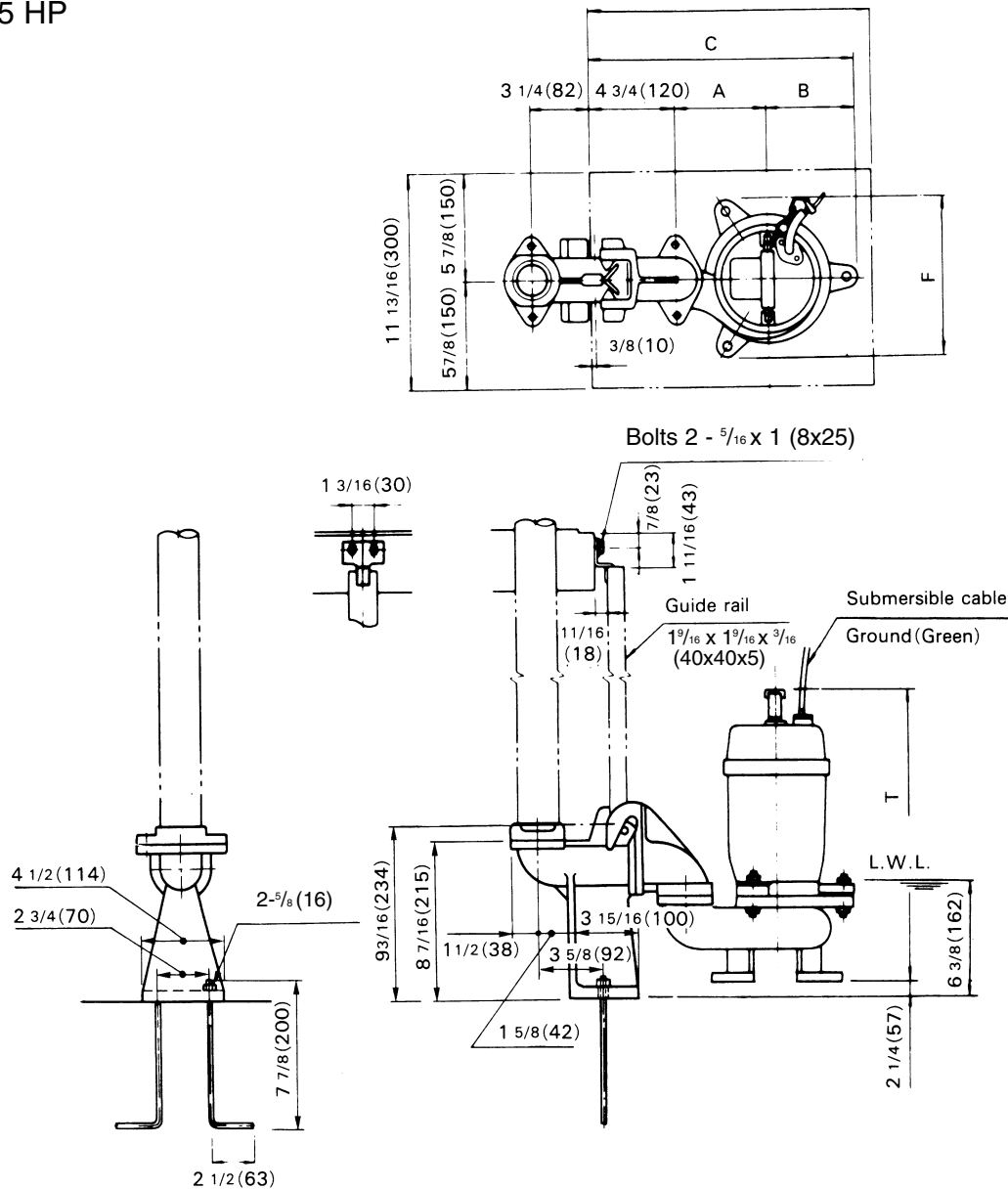

Dimensions: inch

PHASE	SIZE ø	PUMP MODEL	OUTPUT		Q.D.C. MODEL	PUMP & MOTOR					WEIGHT Lb	
			kW	HP		A	B	C	F	T	PUMP	Q.D.C.
THREE	2	50DVSHU6.4	0.4	1/2	LS50	4 5/16	3 9/16	12 5/8	6 5/16	15 7/16	31	20
		50DVSHU6.75	0.75	1	LS50	4 15/16	3 3/8	13 1/16	6 3/4	15 3/8	42	20
		50DVSHU61.5	1.5	2	LS50	4 15/16	3 3/8	13 1/16	6 3/4	17 5/16	60	20

Dimensions: mm

PHASE	SIZE ø	PUMP MODEL	OUTPUT		Q.D.C. MODEL	PUMP & MOTOR					WEIGHT kg	
			kW	HP		A	B	C	F	T	PUMP	Q.D.C.
THREE	50	50DVSHU6.4	0.4	1/2	LS50	110	91	321	160	392	14	9
		50DVSHU6.75	0.75	1	LS50	125	86	331	171	391	19	9
		50DVSHU61.5	1.5	2	LS50	125	86	331	171	440	27	9

Dimensions

Project: _____ Model: _____ Chk'd: _____ Date: _____

Model DVSHU

Hot Water Pumps with Quick Discharge Connector
80DVSHU, 1 to 5 HP

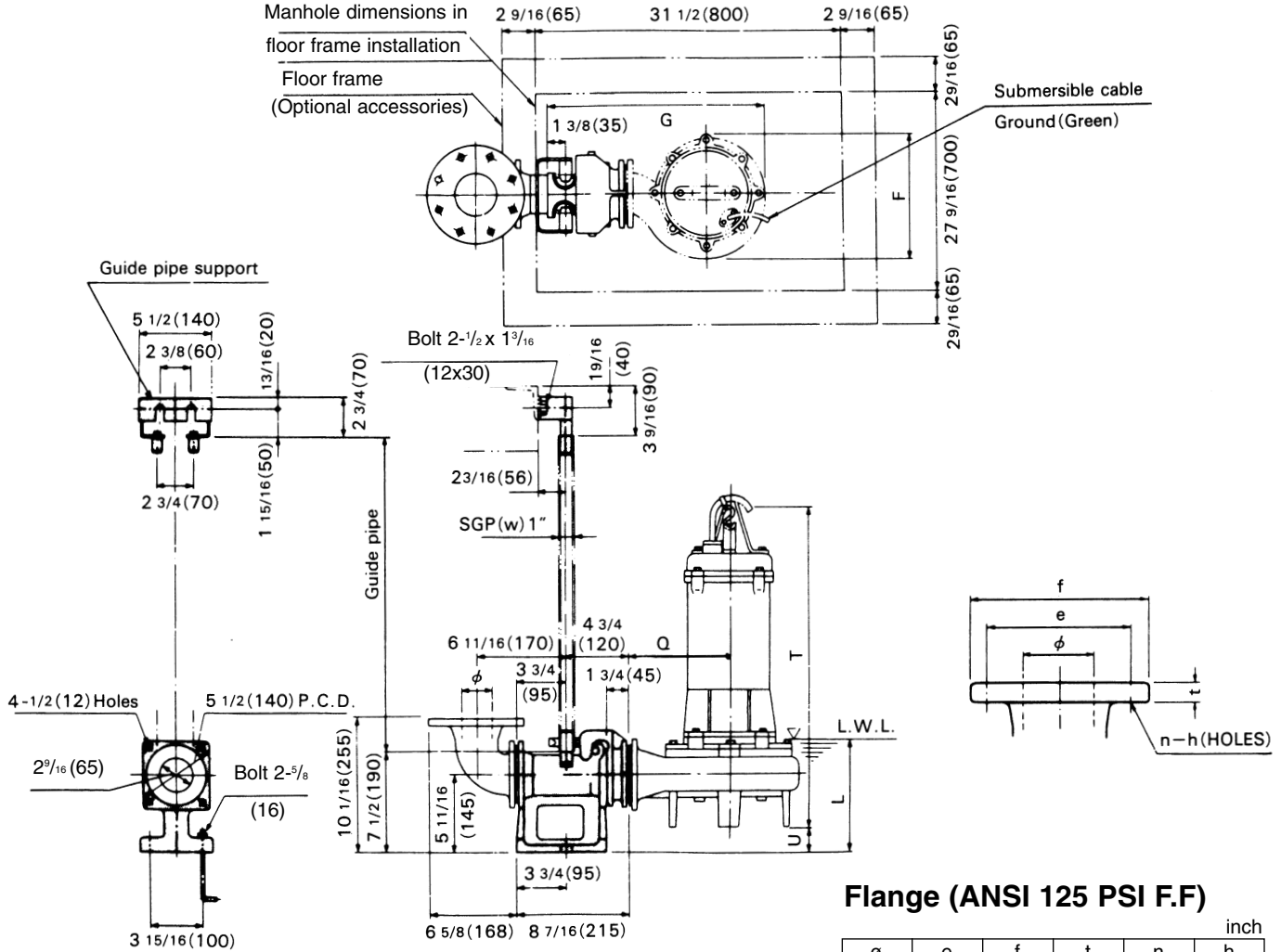

Dimensions: inch

PHASE	SIZE ø	PUMP MODEL	OUTPUT		Q.D.C. MODEL	PUMP & MOTOR						WEIGHT Lb	
			kW	HP		F	G	L	Q	T	U	PUMP	Q.D.C.
THREE	3	80DVSHU6.75	0.75	1	LM65	8	15 ¹¹ / ₁₆	7 ³ / ₄	5 ¹¹ / ₁₆	18 ³ / ₈	2 ¹³ / ₁₆	57	31
		80DVSHU61.5	1.5	2	LM65	8	15 ¹¹ / ₁₆	7 ³ / ₄	5 ¹¹ / ₁₆	20 ⁷ / ₁₆	2 ¹³ / ₁₆	77	31
		80DVSHU62.2	2.2	3	LM65	12 ¹⁵ / ₁₆	16 ⁷ / ₈	8 ¹ / ₄	6 ⁵ / ₁₆	25 ⁷ / ₈	1 ¹⁵ / ₁₆	112	31
		80DVSHU63.7	3.7	5	LM65	12 ¹⁵ / ₁₆	16 ⁷ / ₈	8 ¹ / ₄	6 ⁵ / ₁₆	27 ³ / ₁₆	1 ¹⁵ / ₁₆	132	31

Dimensions: mm

PHASE	SIZE ø	PUMP MODEL	OUTPUT		Q.D.C. MODEL	PUMP & MOTOR						WEIGHT kg	
			kW	HP		F	G	L	Q	T	U	PUMP	Q.D.C.
THREE	80	80DVSHU6.75	0.75	1	LM65	203	398	197	145	467	72	26	14
		80DVSHU61.5	1.5	2	LM65	203	398	197	145	519	72	35	14
		80DVSHU62.2	2.2	3	LM65	328	429	204	160	658	49	51	14
		80DVSHU63.7	3.7	5	LM65	328	429	204	160	691	49	60	14

Dimensions

Project: _____ Model: _____ Chk'd: _____ Date: _____

Model DVSU
with Quick Discharge Connector
80DVSU, 3 to 5 HP

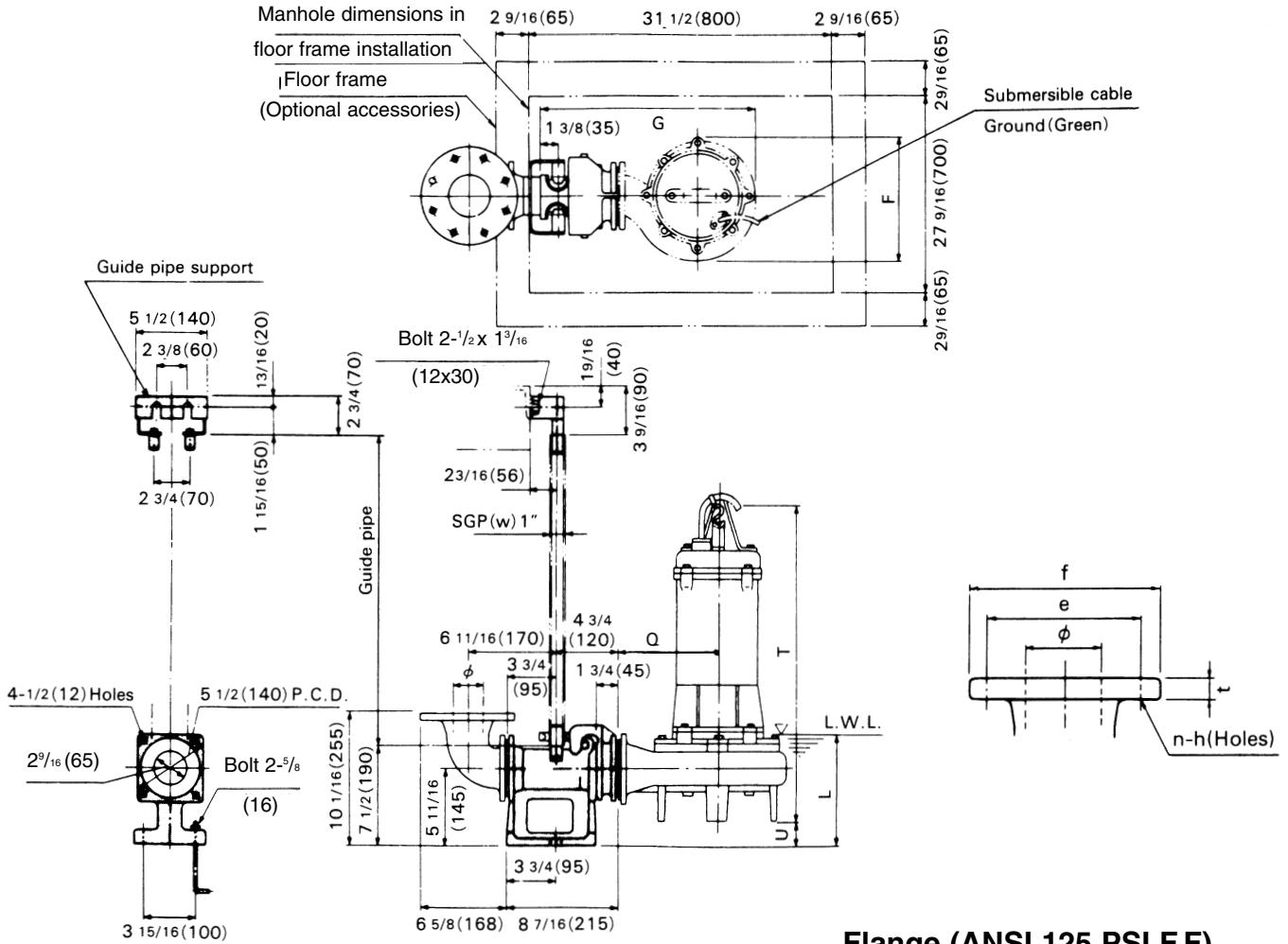

Flange (ANSI 125 PSI F.F)

inch					
ø	e	f	t	n	h
3	6	7 1/2	3/4	4	3/4
mm					
ø	e	f	t	n	h
80	152	191	19	4	19

Dimensions: inch

PHASE	SIZE ø	PUMP MODEL	OUTPUT		Q.D.C. MODEL	PUMP & MOTOR					WEIGHT Lb		
			kW	HP		F	G	L	Q	T	U	PUMP	Q.D.C.
THREE	3	80DVSU62.2	2.2	3	LM65	12 15/16	16 7/8	8 1/16	6 5/16	28 5/8	1 15/16	112	31
		80DVSU63.7	3.7	5	LM65	12 15/16	16 7/8	8 1/16	6 5/16	28 5/8	1 15/16	132	31

Dimensions: mm

PHASE	SIZE ø	PUMP MODEL	OUTPUT		Q.D.C. MODEL	PUMP & MOTOR					WEIGHT kg		
			kW	HP		F	G	L	Q	T	U	PUMP	Q.D.C.
THREE	80	80DVSU62.2	2.2	3	LM65	328	429	204	160	727	49	51	14
		80DVSU63.7	3.7	5	LM65	328	429	204	160	727	49	60	14

Sectional View

Project: _____ Model: _____ Chk'd: _____ Date: _____

Model DVSHU
Hot Water Pumps
1/2 to 5 HP

50DVSU, DVSHU

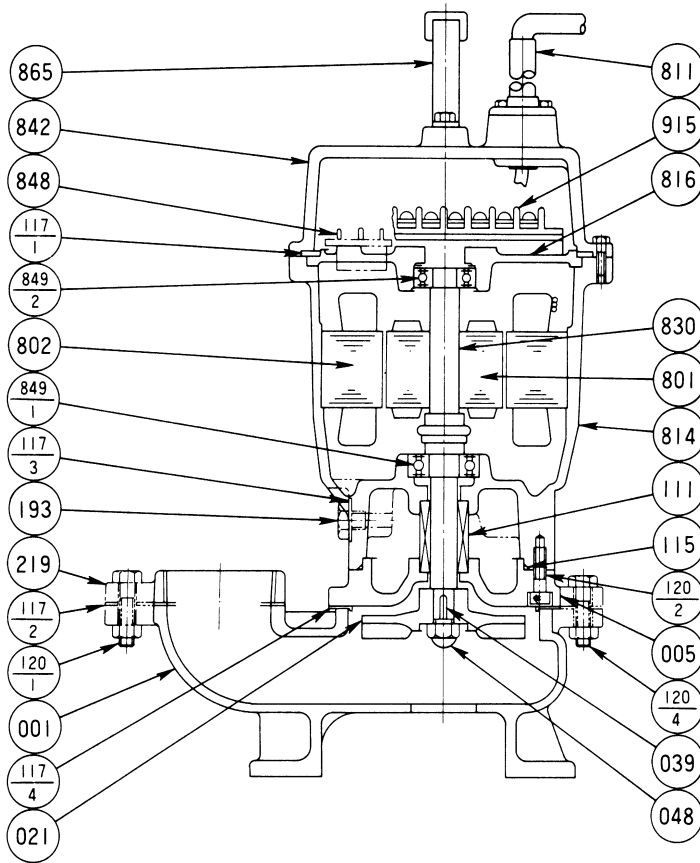

80DVSU, DVSHU

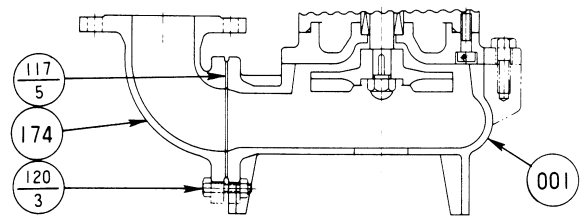

PART NO.	PART NAME	MATERIAL	ASTM, AISI CODE	NO. FOR 1 UNIT
001	CASING	CAST IRON	A48 Class 30	1
005	INTERMEDIATE CASING	CAST IRON	A48 Class 30	1
021	IMPELLER	CAST IRON	A48 Class 30	1
039	KEY	420 STAINLESS	AISI420	1
048	IMPELLER NUT	STEEL	A283 Grade D	1
†111	MECHANICAL SEAL	—		1
†115	O-RING	RUBBER (NBR)		1
†117-1	GASKET	RUBBER (NBR)		1
†117-2	GASKET	RUBBER (CR or NBR)		1
†117-3	GASKET			1
†117-4	GASKET	RUBBER (NR)		1
†117-5	GASKET			1
120-1	BOLT	304 STAINLESS	AISI304	2
120-2	BOLT	304 STAINLESS	AISI304	3 or 4
120-3	BOLT	304 STAINLESS	AISI304	4
120-4	BOLT	304 STAINLESS	AISI304	3 or 4

PART NO.	PART NAME	MATERIAL	ASTM, AISI CODE	NO. FOR 1 UNIT
174	DISCHARGE ELBOW	CAST IRON	A48 Class 30	1
193	OIL PLUG	316 STAINLESS	AISI 304	1
219	COMPANION FLANGE	CAST IRON	A48 Class 30	1
801	ROTOR	—		1
802	STATOR	—		1
811	SUBMERSIBLE CABLE	—		1
814	MOTOR FRAME	CAST IRON	A48 Class 30	1
816	BRACKET	CAST IRON	A48 Class 30	1
830	SHAFT	403 STAINLESS	AISI403	1
842	MOTOR COVER	CAST IRON	A48 Class 30	1
848	MOTOR PROTECTOR	—		1
†849-1	BALL BEARING	—		1
†849-2	BALL BEARING	—		1
865	HANDLE	304 STAINLESS	AISI304	1
915	EXTERNAL TERMINAL	—		1

Motors are purchased as a complete unit.
Parts No. 915 is not installed for DVSHU.

Sectional View

Project: _____ Model: _____ Chk'd: _____ Date: _____

Model DVSU, DVSHU
 Hot Water Pumps
 3 to 5 HP

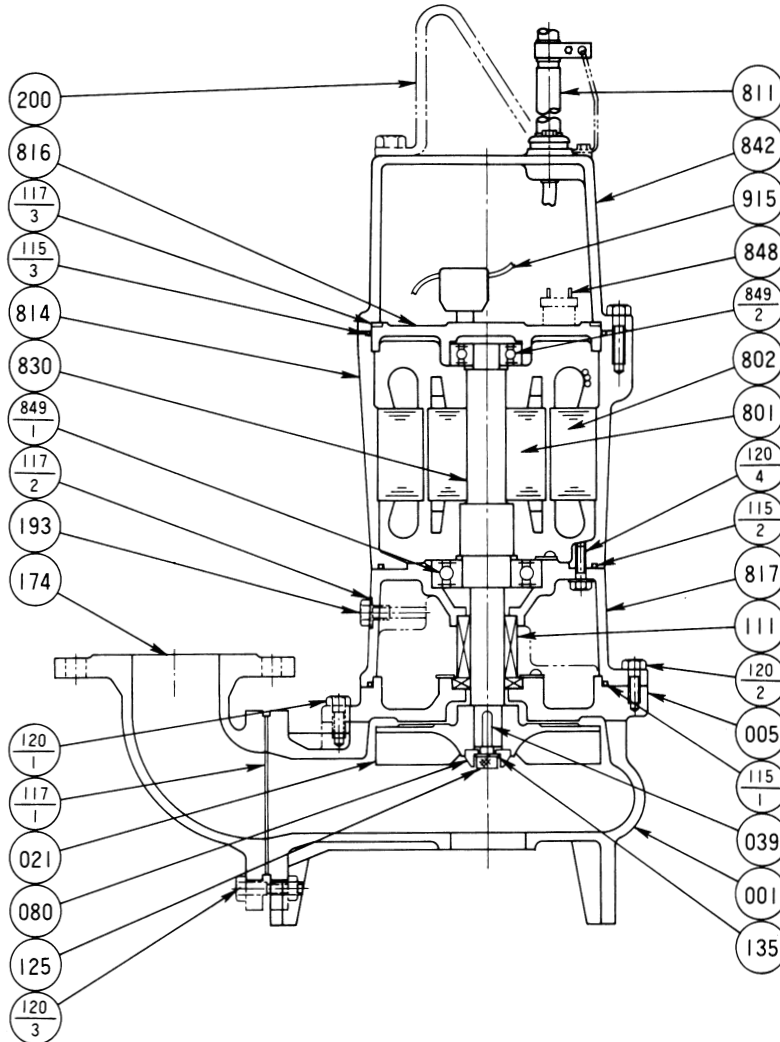

Motors are purchased as a complete unit.
 Parts No. 915 is not installed for DVSHU.

PART NO.	PART NAME	MATERIAL	ASTM, AISI CODE	NO. FOR 1 UNIT	PART NO.	PART NAME	MATERIAL	ASTM, AISI CODE	NO. FOR 1 UNIT
001	CASING	CAST IRON	A48 Class 30	1	135	WASHER	304 STAINLESS	AISI304	1
005	INTERMEDIATE CASING	CAST IRON	A48 Class 30	1	174	DISCHARGE ELBOW	CAST IRON	A48 Class 30	1
021	IMPELLER	CAST IRON	A48 Class 30	1	193	OIL PLUG	316 STAINLESS	AISI316	1
039	KEY	420 STAINLESS	AISI420	1	200	LIFTING HANGER	STEEL	A283 Grade D	1
080	BUSHING	STEEL	A283 Grade D	1	801	ROTOR	—	—	1
†111	MECHANICAL SEAL	—	—	1	802	STATOR	—	—	1
†115-1	O-RING	RUBBER (NBR)	—	1	811	SUBMERSIBLE CABLE	—	—	1
†115-2	O-RING	RUBBER (NBR)	—	1	814	MOTOR FRAME	CAST IRON	A48 Class 30	1
†115-3	O-RING	RUBBER (NBR)	—	2	816	BRACKET	CAST IRON	A48 Class 30	1
†117-1	GASKET	—	—	1	817	BRACKET	CAST IRON	A48 Class 30	1
†117-2	GASKET	—	—	1	830	SHAFT	403 STAINLESS	AISI403	1
†117-3	GASKET	RUBBER (NBR)	—	1	842	MOTOR COVER	CAST IRON	A48 Class 30	1
120-1	BOLT	304 STAINLESS	AISI304	4	848	MOTOR PROTECTOR	—	—	1
120-2	BOLT	304 STAINLESS	AISI304	4	†849-1	BALL BEARING	—	—	1
120-3	BOLT	304 STAINLESS	AISI304	4	†849-2	BALL BEARING	—	—	1
120-4	BOLT	304 STAINLESS	AISI304	4	915	EXTERNAL TERMINAL	—	—	1
125	BOLT	304 STAINLESS	AISI304	1					

†: Recommended spare parts.