

**Technical Data – Contents**

<b>Section</b>	<b>Page</b>
Motor Protection	3-238
Thrust Bearing Thermal Protection	3-239
Leakage Detector	3-240
Cable Entry	3-241
Cable Connector	3-241.1
Mechanical Seal Sectional DWG	3-242
Mechanical Seal Lubricating Oil Qty DSC3/DSC3A	3-243
Mechanical Seal Lubricating Oil Qty DSZ3	3-245
Mechanical Seal & Bearing Specifications	3-246
Bearing Lubrication	3-248
Paint Specifications	3-248
Special Tool List	3-249
Hydraulic Data	3-250

**Technical Data**

Project: \_\_\_\_\_ Model: \_\_\_\_\_ Chk'd: \_\_\_\_\_ Date: \_\_\_\_\_

**Thermal Protection**

The motor shall be equipped with a protector such as automatic cut-off device and thermal protector. The motors described below shall incorporate Miniature Thermal Protectors (MTP) which are embedded in the windings.

When temperature of the winding raises and reaches the MTP acting point, the motor protection circuit is activated to protect motor from over heat.

**1. Applicable model**

Model: DSC/DSCA, DSZ

**2. MTP Specifications:**

Model	KLIXON 9700K-66-215
Type of Contact	b (Normal-contact Acting-open)
Acting Temperature	140±5°C (284±9°F)
Re-setting Temperature	85±10°C (185±18°F)
Capacity of Contact	

Voltage (V)	DC 24	AC 115	AC 230	AC 460
Amperage (A)	18	18	13	5.5

**3. Installation:**

MTP shall be embedded in the stator windings as shown at right—

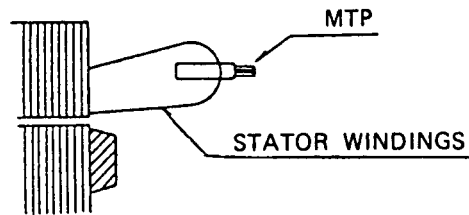

**4. Construction:**

Construction of the MTP is as shown below:

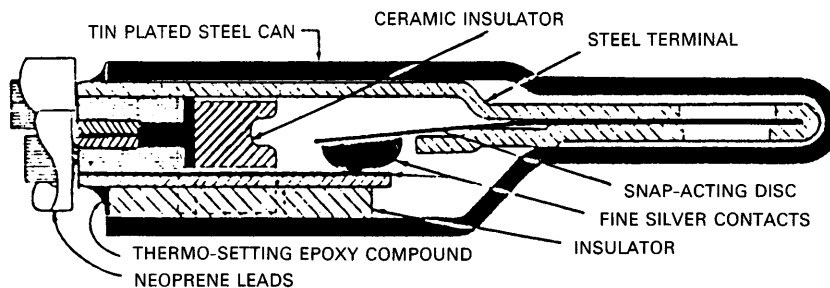

Technical Data

Project: \_\_\_\_\_ Model: \_\_\_\_\_ Chk'd: \_\_\_\_\_ Date: \_\_\_\_\_

Thermal Detector for Thrust Bearing

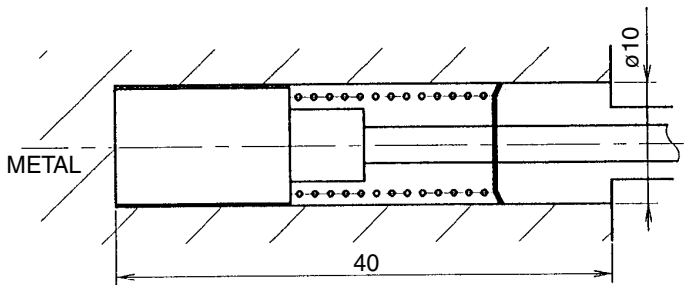
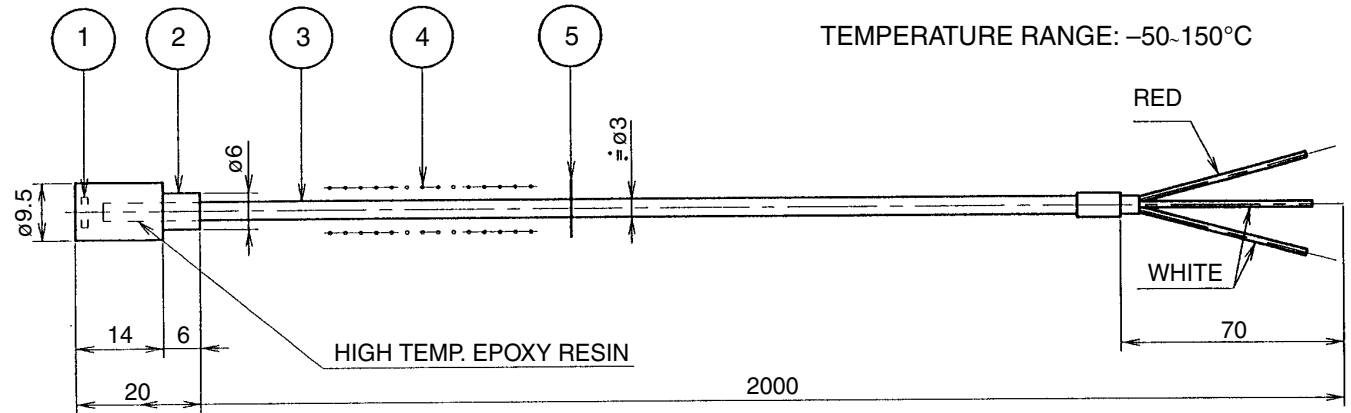

FIG. 5-5 R.T.D.

UNIT : mm

ASSEMBLY OF BEARING  
TYPE TEMP. DETECTOR

No.	Parts	Material	Remarks
1	Resistance Bulb	—	Pt 100 ohm at 0°C Max. current: 5 mA
2	Cap	Stainless Steel	
3	Lead Wires	—	7/ø0.16 Teflon-Teflon
4	Spring	Stainless Steel	
5	Self Lock Retaining Ring	Spring Steel	

Recommended bearing high temp. trip setting: 85°C (185°F)

**Technical Data**

Project: \_\_\_\_\_ Model: \_\_\_\_\_ Chk'd: \_\_\_\_\_ Date: \_\_\_\_\_

**Leakage Detector**

A built-in float type leakage detector with an encapsulated dry reed switch within the stem is fitted to sense leaking of pumping water and/or seal oil into the motor as a result of failure of the mechanical seal.

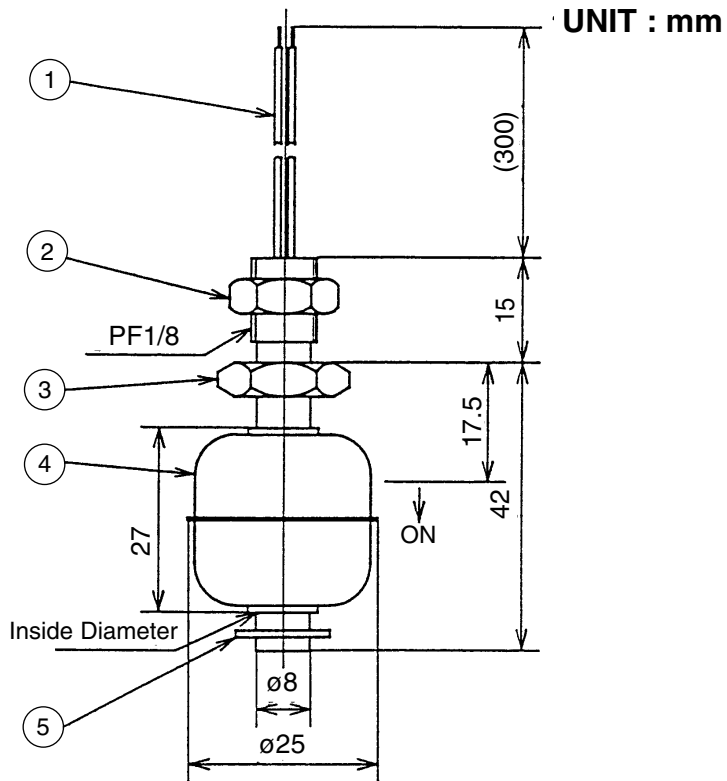

Part No.	Part Name	Part Material	ASTM, AISI Code	No. for 1 Unit
5	Stopper	316 S. Steel	AISI 316	1
4	Float	316 S. Steel	AISI 316	1
3	Housing	316 S. Steel	AISI 316	1
2	Nut	316 S. Steel	AISI 316	1
1	Lead Wire	Heatproof Polyvinyl Chloride Wire (UL1430, AWG22)		2

**SWITCH RATING**

CONTACT RATING : Breaking capacity : AC50VA/DC50W  
 Max. breaking current: AC0.5A/DC0.5A  
 Max. operating voltage : AC300V/DC300V

CONTACT TYPE : B - CONTACT (NORMALLY CLOSED)

**Technical Data**

Project: \_\_\_\_\_ Model: \_\_\_\_\_ Chk'd: \_\_\_\_\_ Date: \_\_\_\_\_

**Cable Seal – (Standard Supply)**

EBARA submersible pump model DSZ3 employs a highly reliable cable entry system with a single piece construction that provides easy maintenance.

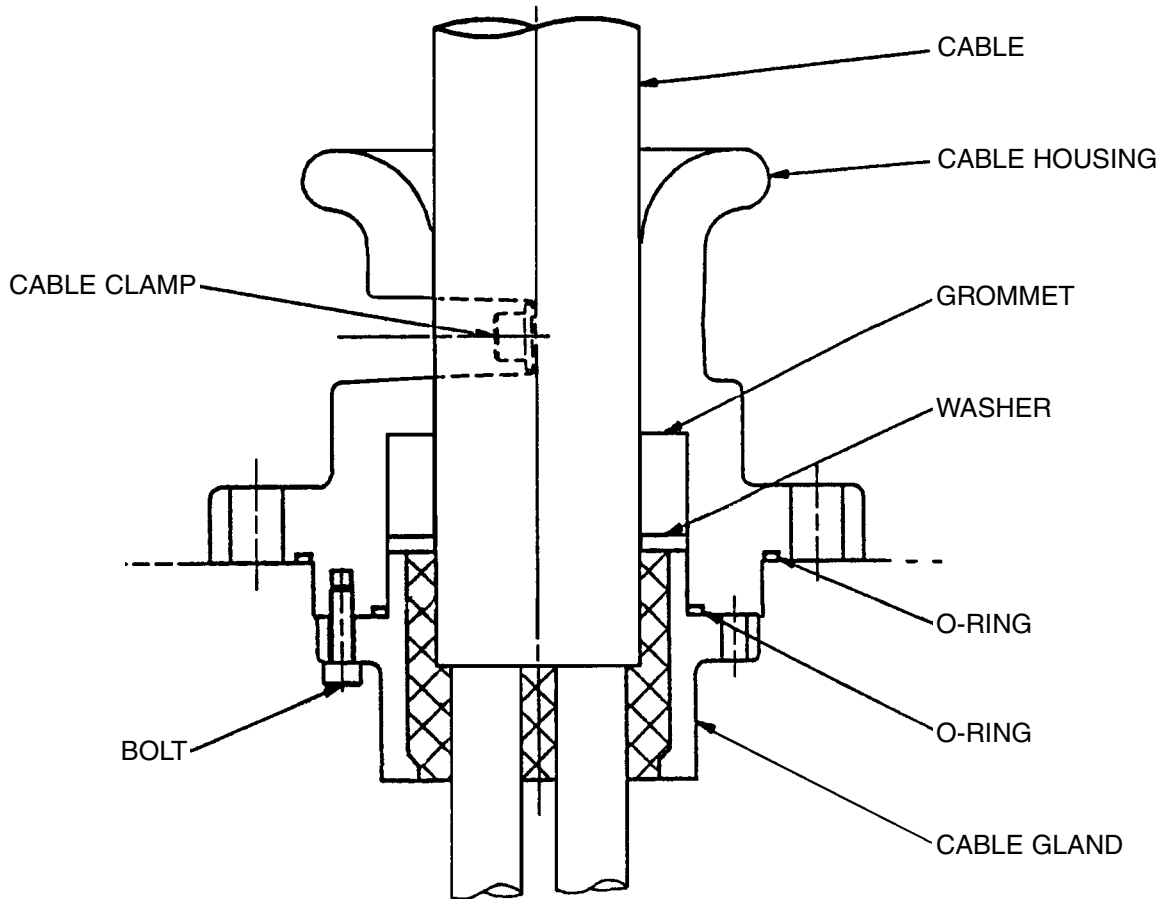

**Technical Data**

Project:

Model:

Chk'd:

Date:

**Cable Connect System**

When a pump is shipped out, a specially prepared cap will be provided in place to cover the cable connection opening; the pump and cable are shipped separately.

**Features:**

- The cable connect system allows for ease in the shipping and handling of larger pumps
  - Decreases the risk of any damage to the heavy cables that can occur during the shipping of larger (50-800 HP) pumps.
- Easy cable connection and disconnection at installation sites
  - During installation or regular maintenance checks, cables can be disconnected from the pump and motor rather than the electrical panel. The pump and motor can then be moved easier or worked on separately from the heavy cable, further eliminating the possibility of damage to the cable.

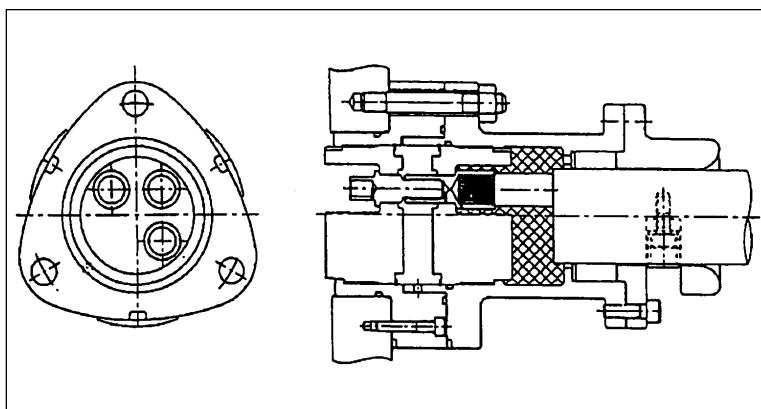

- Functionality of connecting and sealing cables in one system
  - Typically, cable connection occurs at a terminal board inside the motor with sealing at the cable entry point. The Ebara cable connection system functions as the terminal board and cable entry, therefore eliminating the possibility of water entering the motor through the cable.
- Features a triangle connector that eliminates the possibility of erroneous connection that can occur during maintenance.
  - This is a fail-safe system available only with Ebara H-series pumps.
- FMRC approved and is available for both FM explosion proof and non-explosion proof motors on Ebara's H-series pump models.

**Technical Data**

Project: \_\_\_\_\_ Model: \_\_\_\_\_ Chk'd: \_\_\_\_\_ Date: \_\_\_\_\_

**Mechanical Seal – (Standard Supply)**

Ebara DSZ3 pumps employ the cartridge type, duplex mechanical seals in tandem arrangement.

Cartridge type mechanical seal provides

- Easy maintenance because it is handled as one unit
- High reliability due to assembly and adjustment separate from the bowl unit

Duplex mechanical seals in tandem arrangement provide

- High reliability because of dual seals construction
- Long life operation with oil lubrication

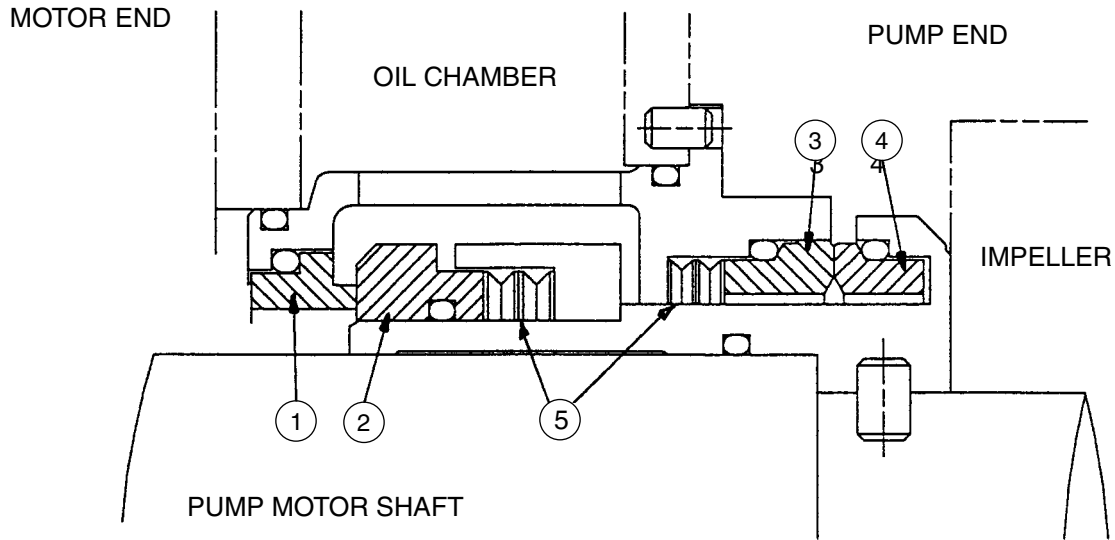

Part No.	Part Name	Material
5	Independent Springs	Stainless Steel
4	Seal Ring (L)	Silicon Carbide
3	Stationary Ring (L)	Silicon Carbide
2	Seal Ring (U)	Ceramic & Stainless Steel
1	Stationary Ring (U)	Carbon

**Lubricating Oil for Mechanical Seal**

Project: \_\_\_\_\_ Model: \_\_\_\_\_ Chk'd: \_\_\_\_\_ Date: \_\_\_\_\_

**Model DSC3/DSCA3**

Curve No.	Pole	KW (HP)	Lubricating Oil (CC)
C1103-1760	4	37 (50)	3700
		45 (60)	3600
		55 (75)	3600
C1203-1770	4	55 (75)	4000
		75 (100)	4000
		90 (120)	5300
C1463-1170	6	45 (60)	5800
		55 (75)	5800
		75 (100)	6500
C1583-1175	6	75 (100)	7500
		90 (120)	7500
		110 (145)	7500
C1583-880	8	30 (40)	5800
		37 (50)	5800
		45 (60)	7900
C1793-885	8	55 (75)	9700
		75 (100)	9400
		75 (100)	11300
C1943-885	8	90 (120)	12200
		110 (145)	12200
		132 (175)	12200
		37 (50)	11700
C1943-710	10	45 (60)	11600
		55 (75)	11600
		75 (100)	12200
		110 (145)	16300
C2113-885	8	132 (175)	16300
		150 (200)	16300
		160 (215)	16300
		185 (245)	16800
		55 (75)	12000
C2113-710	10	75 (100)	16300
		90 (120)	16300
		37 (50)	Contact Ebara
45 (60)			
55 (75)			
C2373-710	10	110 (145)	18800
		132 (175)	18400
		150 (200)	18400
		160 (215)	18400

Curve No.	Pole	KW (HP)	Lubricating Oil (CC)
C2373-593	12	55 (75)	Contact Ebara
		75 (100)	
		90 (120)	
		110 (145)	
C2573-710	10	150 (200)	20400
		160 (215)	20400
		185 (245)	20400
		200 (265)	20400
		220 (295)	20200
		250 (335)	20200
C2573-593	12	90 (120)	Contact Ebara
		110 (145)	
		132 (175)	
C2953-593	12	185 (245)	Contact Ebara
		200 (265)	
		220 (295)	
		250 (335)	
D0852-1760	4	15 (20)	Contact Ebara
		22 (30)	
D0922-1760	4	18.5 (25)	Contact Ebara
		22 (30)	
		30 (40)	
D1002-1760	4	30 (40)	Contact Ebara
		37 (50)	
D1262-1770	4	90 (120)	3300
		110 (145)	5700
		132 (175)	5700
		110 (145)	7500
D1553-1175	6	132 (175)	9200
		150 (200)	9200
		160 (215)	9200
		250 (335)	19800
D2503-710	10	280 (375)	Contact Ebara
		315 (422)	
		355 (475)	
		18.5 (25)	
22 (30)			
30 (40)			



**Lubricating Oil for Mechanical Seal**

Project: \_\_\_\_\_ Model: \_\_\_\_\_ Chk'd: \_\_\_\_\_ Date: \_\_\_\_\_

**Model DSC3/DSCA3**

Curve No.	Pole	KW (HP)	Lubricating Oil (CC)
E0952-1760	4	30 (40)	Contact Ebara
		37 (50)	3800
		45 (60)	3700
		55 (75)	3700
E1052-1760	4	55 (75)	3700
		75 (100)	3700
E1152-1770	4	90 (120)	5700
		110 (145)	570
E1262-1780	4	132 (175)	9100
		150 (200)	9100
		160 (215)	9100
		185 (245)	9100
		200 (265)	12200
		250 (335)	18200
E1543-1180	6	150 (200)	12200
		160 (215)	12000
		185 (245)	12000
		200 (265)	12000
		220 (295)	18200
		250 (335)	18200
E2244-885	8	185 (245)	18200
		200 (265)	18200
		220 (295)	18000
		250 (335)	18000
		280 (375)	18000
E2424-885	8	280 (375)	Contact Ebara
		315 (422)	
		355 (475)	
		400 (535)	
		450 (600)	
F0852-1760	4	30 (40)	Contact Ebara
		37 (50)	3900
		45 (60)	3800
F1102-1780	4	90 (120)	6700
		110 (145)	6700
		132 (175)	6700
		150 (200)	7700
		160 (215)	7700

Curve No.	Pole	KW (HP)	Lubricating Oil (CC)
F1302-1780	4	200 (265)	9300
		220 (295)	9300
		250 (335)	9100
		280 (375)	9100
		315 (422)	Contact Ebara
355 (475)			
F1593-1180	6	400 (535)	Contact Ebara
		220 (295)	
		250 (335)	
		280 (395)	
G0852-1760	4	315 (422)	Contact Ebara
		355 (475)	
		400 (535)	
		37 (50)	
G0932-1770	4	45 (60)	4300
		55 (75)	4200
		75 (100)	4200
G1012-1770	4	75 (100)	4400
		90 (120)	4400
		110 (145)	6400
G1102-1780	4	132 (175)	6400
		150 (200)	7900
		160 (215)	7900
		185 (245)	7900
		200 (265)	7900
G1232-1780	4	220 (295)	7900
		250 (335)	12200
		280 (375)	12000
		315 (422)	Contact Ebara
		355 (475)	



**Lubricating Oil for Mechanical Seal**

Project:

Model:

Chk'd:

Date:

**DSZ3**

Curve No.	Pole	KW (HP)	Lubricating Oil (CC)
A0553-880	8	7.5 (10)	Contact Ebara
		11 (15)	
		15 (20)	
		18.5 (25)	3000
A 713-710	10	18.5 (25)	4700
		22 (30)	4700
		30 (40)	4700
		37 (50)	4700
A0843-710	10	37 (50)	6900
		45 (60)	6900
		55 (75)	6900
		75 (100)	6700
A1003-593	12	55 (75)	Contact Ebara
		75 (100)	
		90 (120)	
C1125-1760	4	22 (30)	Contact Ebara
		30 (40)	
		37 (50)	2700
C1455-1170	6	22 (30)	Contact Ebara
		30 (40)	3400
		37 (50)	3400
		45 (60)	3200
C1605-1170	6	45 (60)	4500
		55 (75)	4500
		75 (100)	4200
C2185-885	8	75 (100)	7100
		90 (120)	7700
		110 (145)	7700
		132 (175)	7600
C2905-710	10	150 (200)	10500
		160 (215)	10500
		185 (245)	10500
		200 (265)	10500
		220 (295)	10400
		250 (335)	10400
V0494-1170	6	18.5 (25)	Contact Ebara
		22 (30)	
		30 (40)	2600
		37 (50)	2600

Curve No.	Pole	KW (HP)	Lubricating Oil (CC)
V0494-880	8	7.5 (10)	Contact Ebara
		11 (15)	
		15 (20)	
V0554-1170	6	37 (50)	2800
		45 (60)	2700
		55 (75)	2700
V0554-880	8	15 (20)	Contact Ebara
		18.5 (25)	2800
		22 (30)	2800
V0754-885	8	30 (40)	2700
		75 (100)	5400
		90 (120)	5700
V0754-710	10	110 (145)	5700
		132 (175)	5600
		37 (50)	5800
V0754-710	10	45 (60)	5800
		55 (75)	5800
		75 (100)	5700
		75 (100)	5700
V0854-710	10	75 (100)	5700
		90 (120)	5700
		110 (145)	5400
V0974-710	10	132 (175)	8800
		150 (200)	8800
		160 (215)	8800
		185 (245)	8800
V1154-593	12	200 (265)	8800
		250 (335)	8800
		150 (200)	Contact Ebara
		160 (215)	
		185 (245)	
		200 (265)	
220 (295)			
250 (335)			
V1154-593	12	280 (375)	Contact Ebara
		315 (442)	



**Mechanical Seal and Ball Bearing Specifications**

Project:

Model:

Chk'd:

Date:

Poles	kW (Hp)	Frame No.	Mechanical Seal Size (Dia. mm)	Ball Bearing Size		
				Lower-Thrust	Thrust BRG Type	Upper-Radial
4	7.5 (10)	Contact EBARA				
	11 (15)					
	15 (20)					
	18.5 (25)					
	22 (30)					
	30 (40)					
	37 (50)	292	63	7220BDB	Double Row	6212ZZ
	45 (60)	292	75	7220BDB	Double Row	6212ZZ
	55 (75)	292	75	7220BDB	Double Row	6212ZZ
	75 (100)	292	75	7220BDB	Double Row	6212ZZ
	90 (120)	380	100	7222BDB	Double Row	6216ZZ
	110 (145)	380	100	7222BDB	Double Row	6216ZZ
	132 (175)	380	100	7222BDB	Double Row	6216ZZ
	150 (200)	480	100	7226B+QJ	Double Row	6218ZZ
	160 (215)	480	100	7226B+QJ	Double Row	6218ZZ
	185 (245)	480	100	7226B+QJ	Double Row	6218ZZ
	200 (265)	480	100	7226B+QJ	Double Row	6218ZZ
	220 (295)	480	100	7226B+QJ	Double Row	6218ZZ
	250 (335)	590	120	7226BDT+QJ	Triple Row	6220ZZ
	280 (375)	590	120	7226BDT+QJ	Triple Row	6220ZZ
315 (422)	Contact EBARA					
355 (475)						
6	7.5 (10)	Contact EBARA				
	11 (15)					
	15 (20)					
	18.5 (25)					
	22 (30)					
	30 (40)					
	37 (50)	292	63	7214B+QJ	Double Row	6212ZZ
	45 (60)	292	75	7220B+QJ	Double Row	6212ZZ
	55 (75)	292	75	7220B+QJ	Double Row	6212ZZ
	75 (100)	380	100	7222B+QJ	Double Row	6216ZZ
	90 (120)	380	100	7222B+QJ	Double Row	6216ZZ
	110 (145)	380	100	7222B+QJ	Double Row	6216ZZ
	132 (175)	480	100	7222BDT+QJ	Triple Row	6218ZZ
	150 (200)	480	100	7226B+QJ	Double Row	6218ZZ
	160 (215)	480	100	7226B+QJ	Double Row	6218ZZ
	185 (245)	480	120	7226BDT+QJ	Triple Row	6218ZZ
	200 (265)	480	120	7226BDT+QJ	Triple Row	6218ZZ
	220 (295)	590	120	7230BDT+QJ	Triple Row	6220ZZ
	250 (335)	590	120	7230BDT+QJ	Triple Row	6220ZZ
	280 (375)	Contact EBARA				
315 (422)						
355 (475)						



**Mechanical Seal and Ball Bearing Specifications**

Project:

Model:

Chk'd:

Date:

Poles	kW (Hp)	Frame No.	Mechanical Seal Size (Dia. mm)	Ball Bearing Size			
				Lower-Thrust	Thrust BRG Type	Upper-Radial	
8	7.5 (10)			Contact EBARA			
	11 (15)						
	15 (20)						
	18.5 (25)						
	22 (30)	292	63	7214BDB	Double Row	6212ZZ	
	30 (40)	292	75	7220BDB	Double Row	6212ZZ	
	37 (50)	292	75	7220BDB	Double Row	6212ZZ	
	45 (60)	380	63	7216B+QJ	Double Row	6216ZZ	
	55 (75)	380	75	7216B+QJ	Double Row	6216ZZ	
	75 (100)	380	100	7222B+QJ	Double Row	6216ZZ	
	90 (120)	480	100	7222B+QJ	Double Row	6218ZZ	
	110 (145)	480	100	7222B+QJ	Double Row	6218ZZ	
	132 (175)	480	100	7226B+QJ	Double Row	6218ZZ	
	150 (200)	480	100	7226B+QJ	Double Row	6218ZZ	
	160 (215)	480	100	7226BDT+QJ	Triple Row	6218ZZ	
	185 (245)	590	120	7226BDT+QJ	Triple Row	6220ZZ	
	200 (265)	590	120	7226BDT+QJ	Triple Row	6220ZZ	
	220 (295)	590	120	7230BDT+QJ	Triple Row	6220ZZ	
	250 (335)	590	120	7230BDT+QJ	Triple Row	6220ZZ	
	280 (375)	590	135	7230BDT+QJ	Triple Row	6220ZZ	
315 (422)	Contact EBARA						
355 (475)							
400 (535)							
10	15 (20)	380	63	7216DBD	Double Row	6216ZZ	
	18.5 (25)	380	63	7216BDB	Double Row	6216ZZ	
	22 (30)	380	63	7216BDB	Double Row	6216ZZ	
	30 (40)	380	63	7216BDB	Double Row	6216ZZ	
	37 (50)	380	63	7216B+QJ	Double Row	6216ZZ	
	45 (60)	380	75	7216B+QJ	Double Row	6216ZZ	
	55 (75)	380	75	7216B+QJ	Double Row	6216ZZ	
	75 (100)	480	100	7222B+QJ	Double Row	6218ZZ	
	90 (120)	480	100	7222B+QJ	Double Row	6218ZZ	
	110 (145)	480	120	7226B+QJ	Double Row	6218ZZ	
	132 (175)	590	120	7226BDT+QJ	Triple Row	6220ZZ	
	150 (200)	590	120	7226BDT+QJ	Triple Row	6220ZZ	
	160 (215)	590	120	7226BDT+QJ	Triple Row	6220ZZ	
	185 (245)	590	120	7230BDT+QJ	Triple Row	6220ZZ	
	200 (265)	590	120	7230BDT+QJ	Triple Row	6220ZZ	
	220 (295)	590	135	7230BDT+QJ	Triple Row	6220ZZ	
250 (335)	590	135	7230BDT+QJ	Triple Row	6220ZZ		
280 (375)	Contact EBARA						
315 (422)							
12	22 (30)	380	63	7216BDB	Double Row	6216ZZ	
	30 (40)	380	63	7216B+QJ	Double Row	6216ZZ	
	37 (50)	380	63	7216B+QJ	Double Row	6216ZZ	
	45 (60)	380	100	7222BDB	Double Row	6216ZZ	
	55 (75)	480	100	7222B+QJ	Double Row	6218ZZ	
	75 (100)	480	100	7222B+QJ	Double Row	6218ZZ	
	90 (120)	480	100	7222B+QJ	Double Row	6218ZZ	
	110 (145)	590	120	7226BDT+QJ	Triple Row	6220ZZ	
	132 (175)	590	120	7226BDT+QJ	Triple Row	6220ZZ	
	150 (200)	590	120	7226BDT+QJ	Triple Row	6220ZZ	
	160 (215)	590	120	7226BDT+QJ	Triple Row	6220ZZ	
	185 (245)	590	120	7226BDT+QJ	Triple Row	6220ZZ	
	200 (265)	590	120	7230BDT+QJ	Triple Row	6220ZZ	
	220 (295)	590	135	7230BDT+QJ	Triple Row	6220ZZ	
	250 (335)	Contact Ebara					
	280 (375)						
315 (422)							



**Technical Data**

Project: \_\_\_\_\_ Model: \_\_\_\_\_ Chk'd: \_\_\_\_\_ Date: \_\_\_\_\_

**Lubrication**

	<b>Lower Bearing</b>	<b>Upper Bearing</b>	<b>Shaft Seal</b>
Lubricant	Grease	Grease	Turbine Oil (see Note 1)
Standard	NLGI grade 3	Mobil SHC32	ISO VG32
ESSO	UNIREX N3		TERESSO 32
MOBIL	MOBILITH AW3		MOBIL DTE OIL, OIL LIGHT
SHELL	-		SHELL TURBO OIL 32

**Note 1:** Other lubricants may be used when the oil is not allowed.

**Shop Painting**

<b>Coating Spec. No.</b>	<b>I</b>	<b>II</b>	<b>III</b>
Preparation	SSPC - SP - 10	SSPC - SP - 3	SSPC - SP - 10
Materials & coating nos.	Coal tar epoxy paint x 3	Zinc rich primer x 1	Zinc chromate primer x 1 Alkyd resin enamel x 1
Color	Black	Gray	Gray
Total dry film thick. (mill)	8 to 18	.5 to 1	2 to 2.5

Spec. No. I : surfaces contacting pumping liquid

Spec. No. II : internal surface of motor

Spec. No. III : surfaces in air

**Note:** Non-ferrous material and stainless steel are not painted.

**Technical Data**

Project: \_\_\_\_\_ Model: \_\_\_\_\_ Chk'd: \_\_\_\_\_ Date: \_\_\_\_\_

**Special Tool List – (optional supply)**

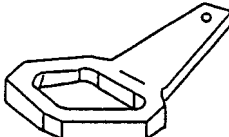
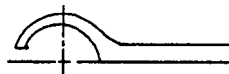
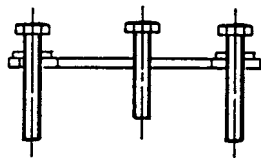
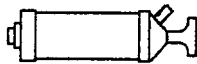
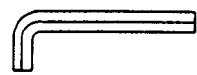
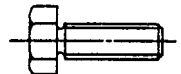
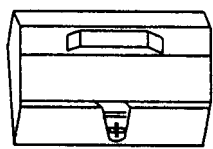
Special Tool List			Drawing No.		
No.	Name	Sketch	Material	Supply	Remarks
1	Impeller Nut Wrench		Steel	1	For impeller nut
2	Hook Spanner		Steel	1~3	For cable supports
3	Extractor		Steel	1	For impeller
4	Oil Pump		-	1	
5	Hexagon Key Wrench		Steel	1 Set	
6	Push Bolt		Steel	2	For mechanical seal
7	Tool Box		Steel	1	

**Hydraulic Data**

Project: \_\_\_\_\_ Model: \_\_\_\_\_ Chk'd: \_\_\_\_\_ Date: \_\_\_\_\_

**General Information**

**1. PUMP RATED CAPACITY AND TOTAL HEAD**

Pumping requirements in the system are stated as **Rated Capacity and Rated Total Head**. Rated capacity is the flow rate determined by the total design capacity of the pumping station and the number of operating pumps.

$$\text{Rated Capacity} = \frac{\text{Total design capacity of pumping station}}{\text{Number of operating pumps}}$$

**Rated Total Head** = System head at the rated capacity.

The pump is operated at the cross point of the pump Q-H (capacity-head) curve and the **System Head Curve** as shown in Fig. 1-1. The head at the cross point is defined as the rated total head of pump.

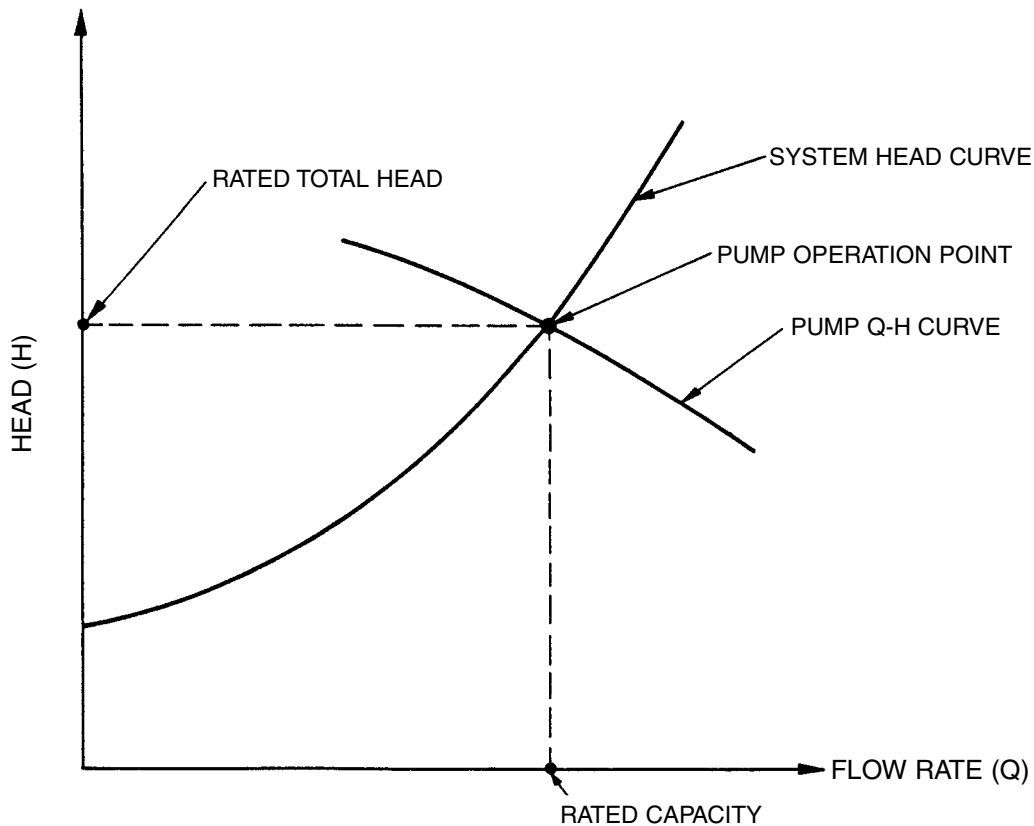

**Fig. 1-1 PUMP OPERATION POINT**

Hydraulic Data

Project:

Model:

Chk'd:

Date:

2. SYSTEM HEAD

System head of the system is the sum of the **Static Head** and the **Dynamic Head**, and its curve is a quadratic curve of the flow rate as shown in Fig. 1-2.

**System Head** = Static head ( $H_a$ ) + Dynamic Head ( $H_d$ )

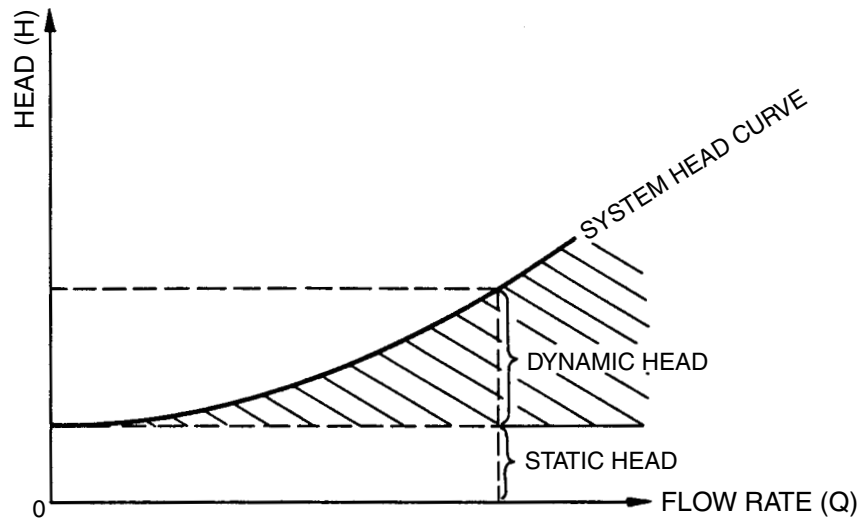

Fig. 1-2 SYSTEM HEAD CURVE

Static Head ( $H_a$ )

Static head arises from the difference between the pump suction pit water level and the discharge water level.

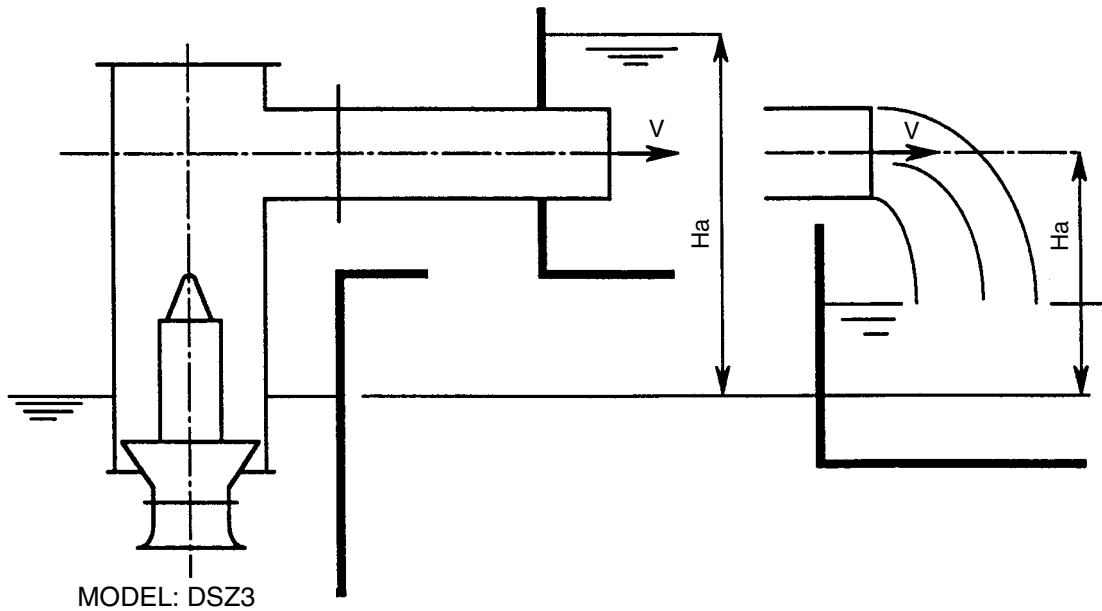

Fig. 1-3-1 STATIC HEAD

**Hydraulic Data**

Project:

Model:

Chk'd:

Date:

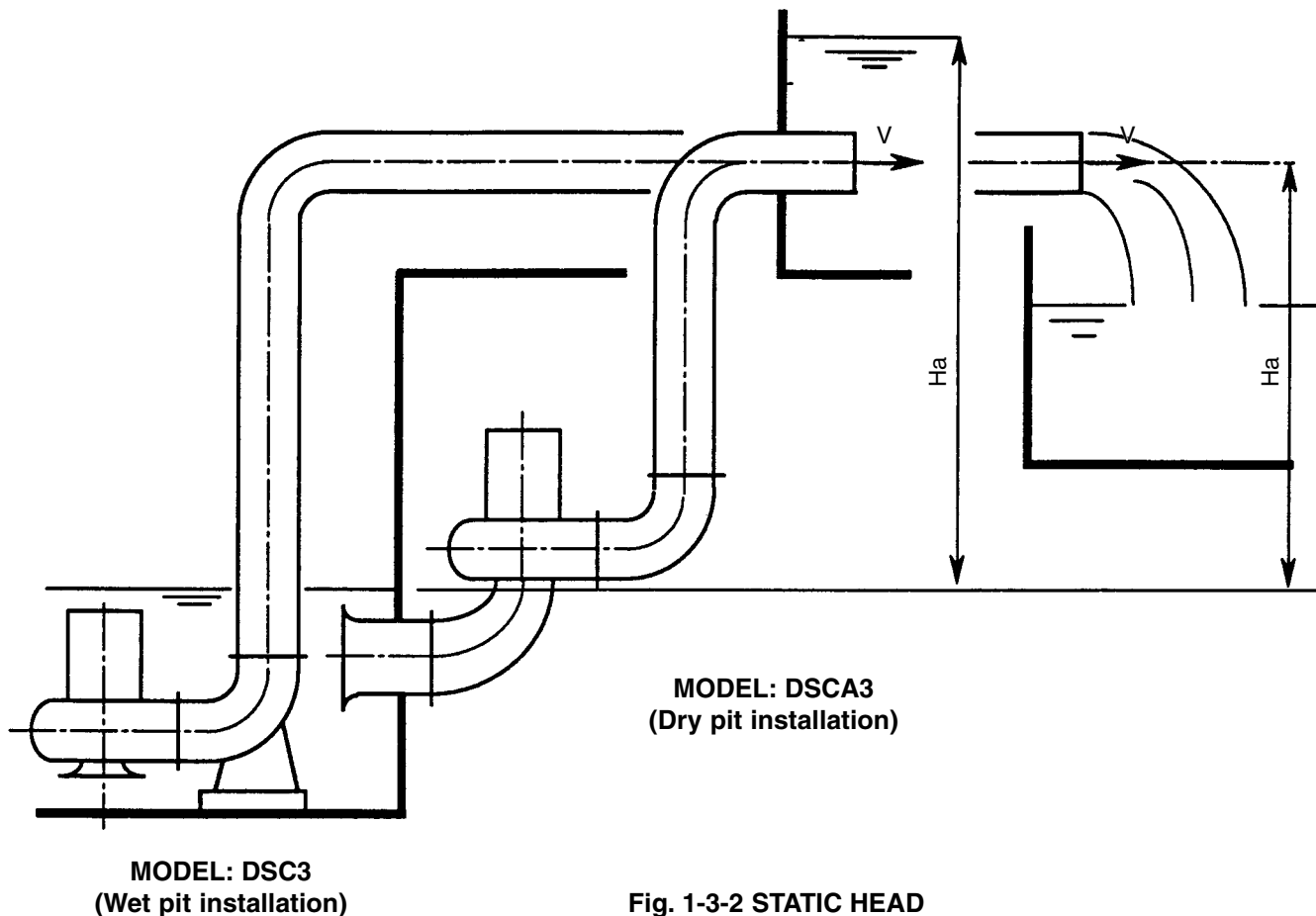

**Dynamic Head (Hd)**

Dynamic head for each case of static head in Fig. 1-3-1,2 is as follows:

$$Hd = Hf + \frac{V^2}{2g}$$

Where,  $Hf$  : Hydraulic loss from the system suction end to the system discharge end except loss in the pump

$\frac{V^2}{2g}$  : Velocity head at the system discharge end

Hydraulic Data

Project: \_\_\_\_\_ Model: \_\_\_\_\_ Chk'd: \_\_\_\_\_ Date: \_\_\_\_\_

**3. PUMP OPERATION RANGE**

As stated in paragraph 1, the pump is operated at the cross point of its Q-H curve and the system head curve. Therefore, so long as the system head curve is not changed, the pump is operated at a design point. In an actual pumping system, however, the static head varies depending on the suction and/or discharge water level. As a result, the system head curve shifts as shown in Fig. 1-4. With this shift in the system head curve, the cross point with pump Q-H varies, and this variation is termed as the **Pump Operation Range**.

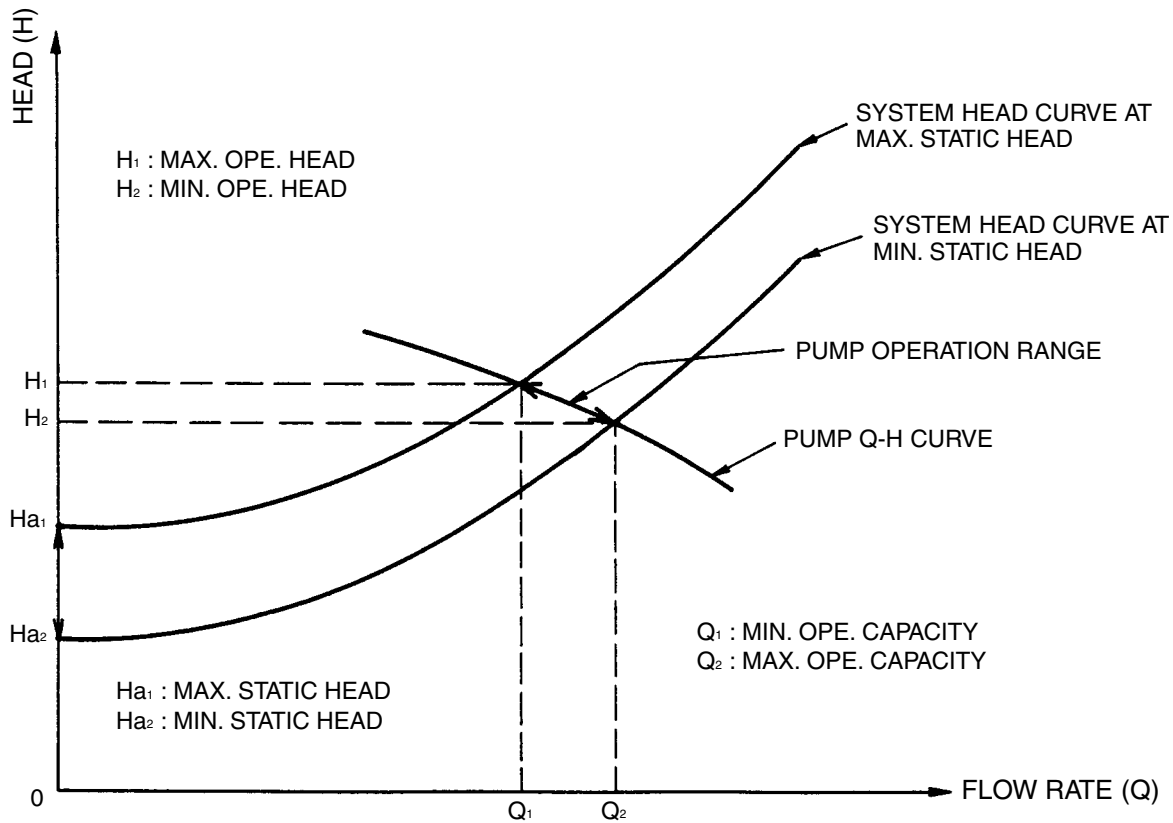

Fig. 1-4 PUMP OPERATION RANGE

**Hydraulic Data**

Project: \_\_\_\_\_ Model: \_\_\_\_\_ Chk'd: \_\_\_\_\_ Date: \_\_\_\_\_

**4. NPSH**

Adequate suction pressure at the impeller inlet is necessary for the pump to perform as designed. This suction pressure (absolute) converted into water head is called **NPSH req.** and is shown on the pump performance curve as one of the pump characteristics.

On the other hand, actual suction pressure (absolute) converted into water head is called **NPSH av.** and is defined as shown in Fig. 1-5.

**NPSH req. shall not exceed NPSH av. in the continuous operation range.**

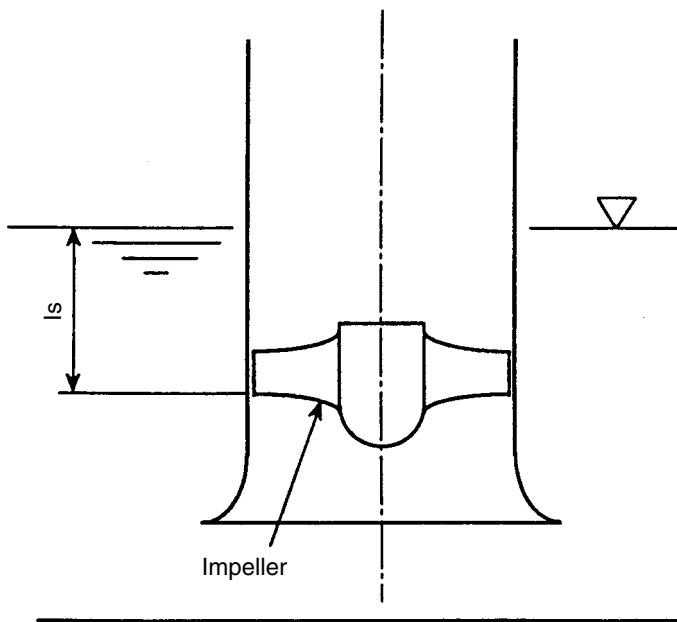

NPSH available (m)

$$\text{NPSH av.} = I_s + P_a - P_v (-P_s)$$

where,

$I_s$  : submergence of impeller (m)

$P_a$  : atmospheric pressure (m)

under 1 atm,  $P_a = 10.3$  m

$P_v$  : vapor pressure (m)

water at 20°C,  $P_v = 0.24$  m

( $P_s$  : friction losses in suction pipe of dry pit (m))

**Fig. 1-5 NPSH av.**

Hydraulic Data

Project:

Model:

Chk'd:

Date:

5. AIR-ENTRAINING VORTEX

Lack of enough submergence causes the generation of harmful air-entraining vortices as shown in Fig. 1-6. The submergence at which generation of vortices can be avoided is termed as the **Minimum Submergence (S)**.

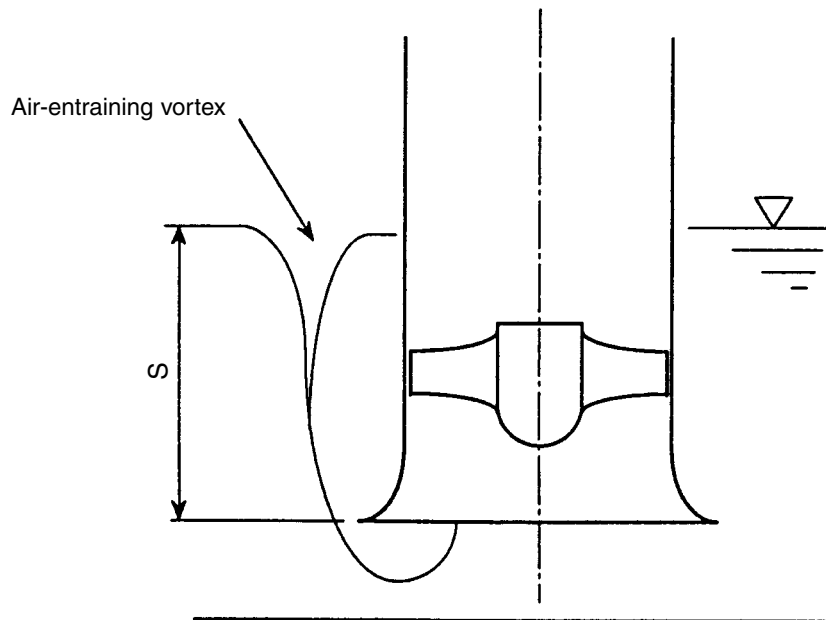

Fig. 1-6 AIR-ENTRAINING VORTEX

**Hydraulic Data**

Project:

Model:

Chk'd:

Date:

**6. SUBSURFACE VORTEX**

In cases where the clearance between pump and walls is not adequate, harmful subsurface vortices generates as shown in Fig. 1-7.

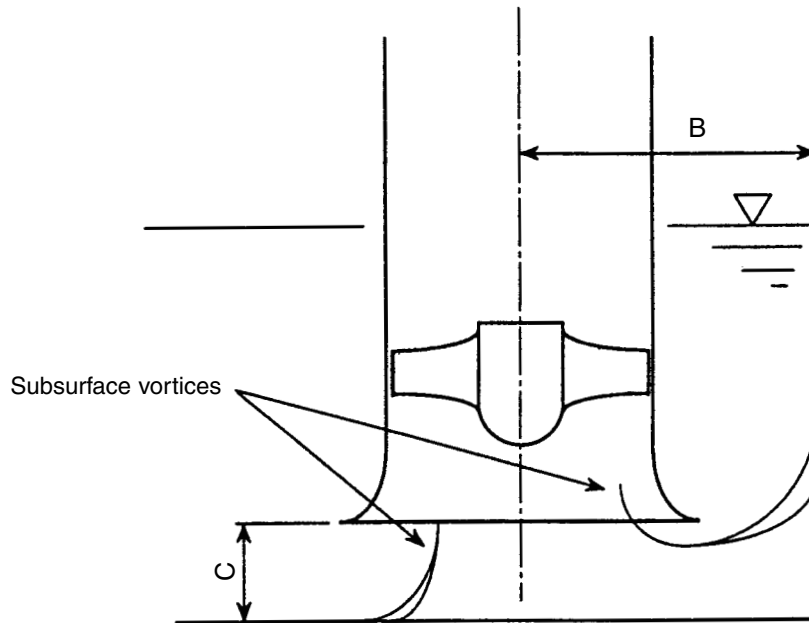

**Fig. 1-7 SUBSURFACE VORTICES**

Hydraulic Data

Project:

Model:

Chk'd:

Date:

Submergence and Clearance

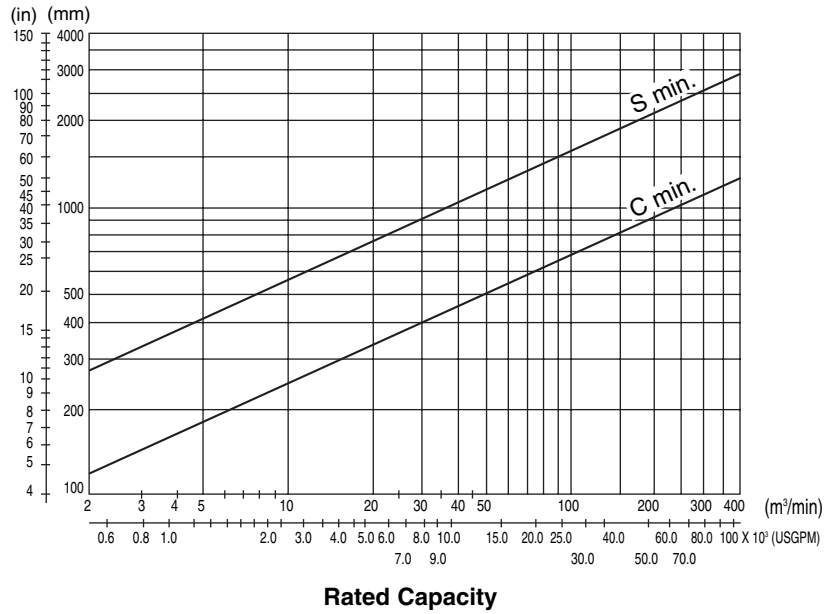
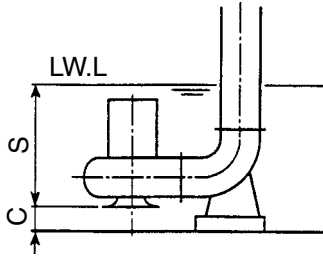

Head Loss at QDC

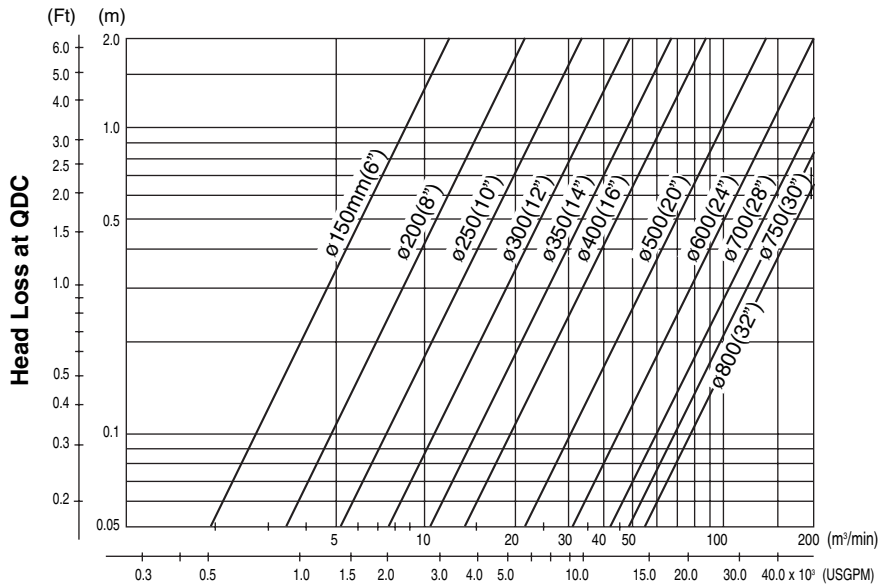

Hydraulic Data

Project:

Model:

Chk'd:

Date:

Submergence and Clearance

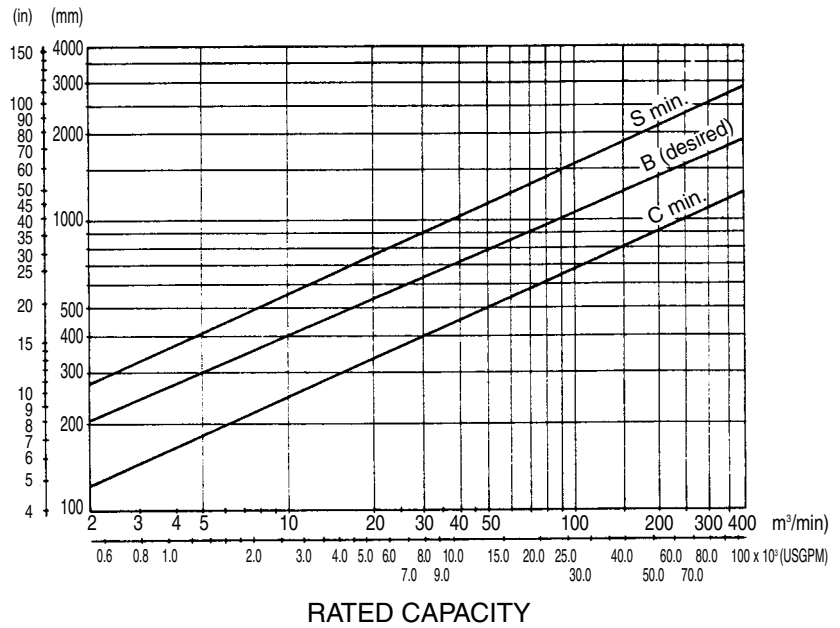
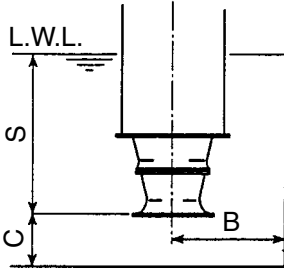

Min. Space for Pumps

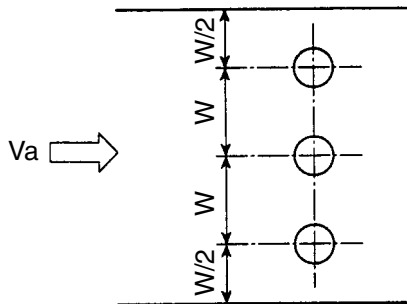

W : Minimum Clearance between Pumps

Va : Approaching Flow Velocity

Va < 0.3 m/s is recommended.

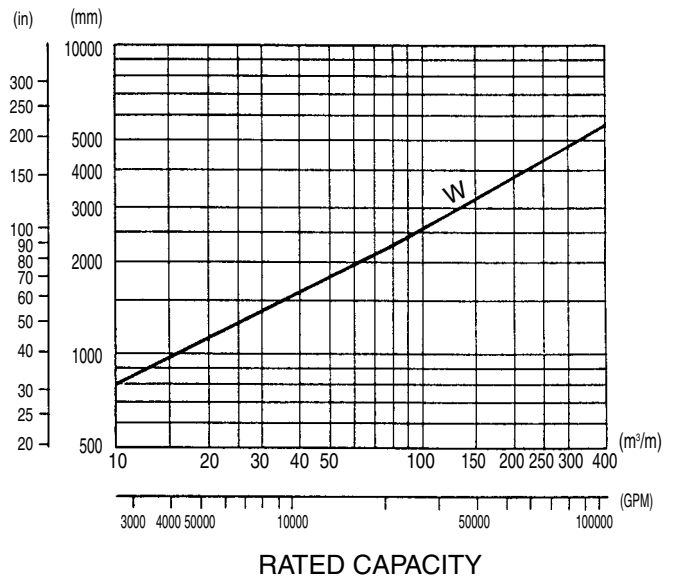

Hydraulic Data

Project:

Model:

Chk'd:

Date:

Pipe Friction Loss

The following figure shows friction loss head per 1 m for straight steel pipe.

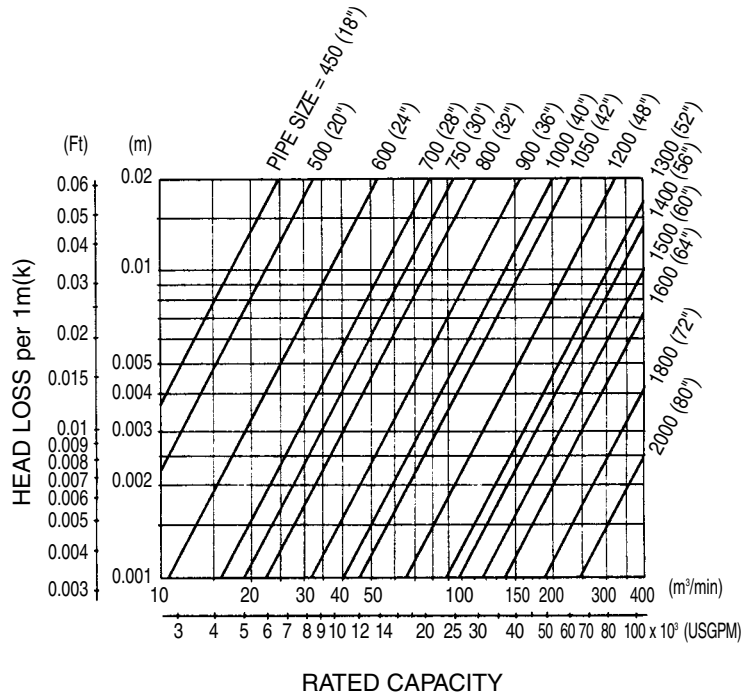

Discharge Head Loss

The head loss of the "Tee" type discharge head can be obtained from the following. This head loss includes friction loss at the discharge nozzle within lengths "F" listed.

UNIT: inch (mm)

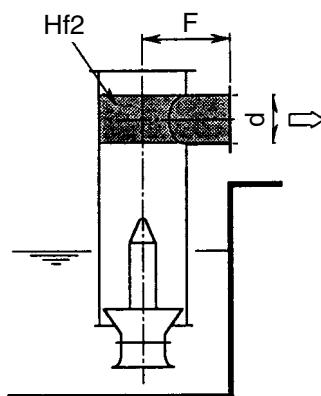

Nozzle Size d	F
12 (300)	13 <sup>3</sup> / <sub>4</sub> (350)
14 (350)	15 <sup>3</sup> / <sub>4</sub> (400)
16 (400)	17 <sup>11</sup> / <sub>16</sub> (450)
18 (450)	19 <sup>11</sup> / <sub>16</sub> (500)
20 (500)	21 <sup>5</sup> / <sub>8</sub> (550)
24 (600)	25 <sup>9</sup> / <sub>16</sub> (650)
28 (700)	29 <sup>1</sup> / <sub>2</sub> (750)
30 (750)	31 <sup>1</sup> / <sub>2</sub> (800)
32 (800)	33 <sup>7</sup> / <sub>16</sub> (850)
36 (900)	37 <sup>3</sup> / <sub>8</sub> (950)
40 (1000)	41 <sup>5</sup> / <sub>16</sub> (1050)
42 (1050)	43 <sup>5</sup> / <sub>16</sub> (1100)
44 (1100)	45 <sup>1</sup> / <sub>4</sub> (1150)
48 (1200)	49 <sup>3</sup> / <sub>16</sub> (1250)
54 (1350)	55 <sup>1</sup> / <sub>8</sub> (1400)
60 (1500)	61 (1550)

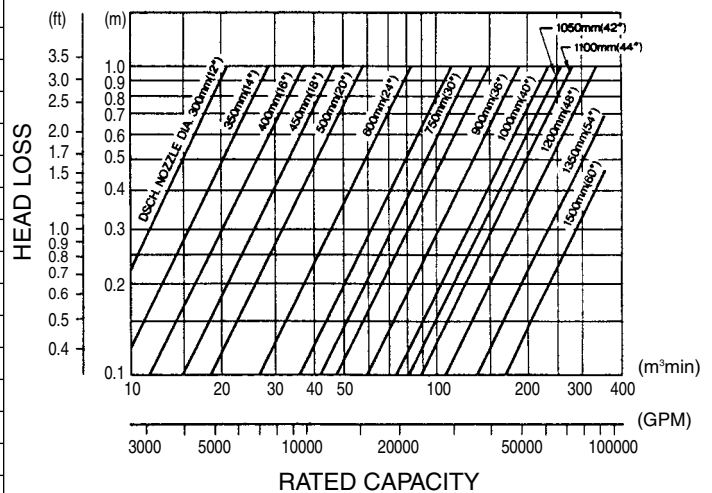

Hydraulic Data

Project: \_\_\_\_\_ Model: \_\_\_\_\_ Chk'd: \_\_\_\_\_ Date: \_\_\_\_\_

Column Pipe Size

As an engineering work guideline, the nominal column pipe size for each unit is listed in DIMENSIONS. The following table shows the recommended pipe dimensions of column pipe for Ebara DSZ3 pump. The wall thicknesses listed below are minimum requirements. If pipes with other thickness are used, check that permissible inside diameter is not smaller than **Min. inside dia. req.**

UNIT: inch (mm)

Nominal Size	Outer Dia.	Inside Dia.	Wall Thickness	Min. Inside Dia. Req.	Weight (Plain End) Lbs/Ft (Kg/M)
18 (450)	18 (457.2)	17 <sup>1</sup> / <sub>2</sub> (444.5)	1/4 (6.4)	17 <sup>1</sup> / <sub>4</sub> (439.9)	47.7 (71.1)
20 (500)	20 (508.0)	19 <sup>1</sup> / <sub>2</sub> (495.3)	1/4 (6.4)	19 <sup>1</sup> / <sub>4</sub> (488.2)	53.1 (79.2)
24 (600)	24 (609.6)	23 <sup>1</sup> / <sub>2</sub> (596.9)	1/4 (6.4)	23 <sup>3</sup> / <sub>16</sub> (588.8)	63.8 (95.2)
28 (700)	28 (711.2)	27 <sup>3</sup> / <sub>8</sub> (695.4)	5/16 (7.9)	27 (685.9)	91.9 (137.0)
30 (750)	30 (762.0)	29 <sup>3</sup> / <sub>8</sub> (746.1)	5/16 (7.9)	29 (736.2)	98.6 (147.0)
32 (800)	32 (812.8)	31 <sup>3</sup> / <sub>8</sub> (796.4)	5/16 (7.9)	30 <sup>15</sup> / <sub>16</sub> (786.0)	105.3 (157.0)
36 (900)	36 (914.4)	35 <sup>3</sup> / <sub>8</sub> (898.5)	5/16 (7.9)	34 <sup>15</sup> / <sub>16</sub> (887.1)	118.7 (177.0)
40 (1000)	40 (1016.0)	39 <sup>3</sup> / <sub>8</sub> (1000.2)	5/16 (7.9)	38 <sup>7</sup> / <sub>8</sub> (987.7)	130.8 (195.0)
42 (1050)	42 (1066.8)	41 <sup>1</sup> / <sub>4</sub> (1047.8)	3/8 (9.5)	40 <sup>3</sup> / <sub>4</sub> (1034.3)	167.1 (249.2)
48 (1200)	48 (1219.2)	47 <sup>1</sup> / <sub>2</sub> (1200.2)	3/8 (9.5)	46 <sup>11</sup> / <sub>16</sub> (1185.2)	189.8 (283.0)
54 (1350)	54 (1371.6)	53 <sup>1</sup> / <sub>8</sub> (1347.8)	7/16 (11.9)	52 <sup>3</sup> / <sub>8</sub> (1330.5)	267.6 (399.0)
56 (1400)	56 (1422.4)	55 <sup>1</sup> / <sub>8</sub> (1398.6)	7/16 (11.9)	54 <sup>3</sup> / <sub>8</sub> (1380.8)	279.2 (416.4)
60 (1500)	60 (1524.0)	59 <sup>1</sup> / <sub>8</sub> (1500.2)	7/16 (11.9)	58 <sup>5</sup> / <sub>8</sub> (1481.4)	297.7 (444.0)
64 (1600)	64 (1625.6)	63 (1599.4)	1/2 (13.1)	62 <sup>3</sup> / <sub>8</sub> (1579.2)	349.4 (521.0)
72 (1800)	72 (1828.8)	71 (1802.6)	1/2 (13.1)	70 <sup>1</sup> / <sub>8</sub> (1780.4)	393.6 (587.0)
80 (2000)	80 (2032.8)	78 <sup>13</sup> / <sub>16</sub> (2001.8)	5/8 (15.1)	77 <sup>13</sup> / <sub>16</sub> (1977.0)	506.6 (755.5)

Typical Foundation Plan

The following gives the typical foundation plan for each size of column pipe.

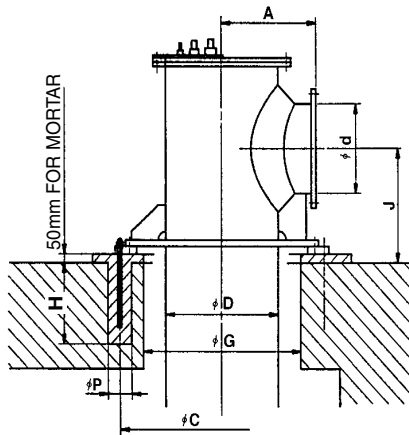

UNIT: inch (mm)

D	A	G						d	J
			P.C.D.	No.	Size	P	H		
20 (500)	17 <sup>11</sup> / <sub>16</sub> (450)	29 <sup>1</sup> / <sub>2</sub> (750)	43 <sup>3</sup> / <sub>16</sub> (1100)	4	7/8 (M22)	5 <sup>7</sup> / <sub>8</sub> (150)	16 <sup>5</sup> / <sub>16</sub> (430)	14 (350)	17 <sup>11</sup> / <sub>16</sub> (450)
24 (600)	21 <sup>5</sup> / <sub>8</sub> (550)	33 <sup>3</sup> / <sub>16</sub> (850)	47 <sup>1</sup> / <sub>4</sub> (1200)	4	15/16 (M24)	5 <sup>7</sup> / <sub>8</sub> (150)	19 <sup>1</sup> / <sub>16</sub> (500)	16 (400)	19 <sup>11</sup> / <sub>16</sub> (500)
30 (750)	25 <sup>9</sup> / <sub>16</sub> (650)	41 <sup>1</sup> / <sub>8</sub> (1050)	55 <sup>5</sup> / <sub>8</sub> (1400)	6	15/16 (M24)	5 <sup>7</sup> / <sub>8</sub> (150)	19 <sup>1</sup> / <sub>16</sub> (500)	18 (450)	21 <sup>5</sup> / <sub>8</sub> (550)
36 (900)	31 <sup>1</sup> / <sub>2</sub> (800)	47 <sup>1</sup> / <sub>4</sub> (1200)	63 (1600)	6	1 <sup>9</sup> / <sub>16</sub> (M30)	5 <sup>7</sup> / <sub>8</sub> (150)	24 <sup>3</sup> / <sub>16</sub> (630)	20 (500)	23 <sup>3</sup> / <sub>8</sub> (600)
40 (1000)	33 <sup>3</sup> / <sub>16</sub> (850)	51 <sup>1</sup> / <sub>8</sub> (1300)	66 <sup>15</sup> / <sub>16</sub> (1700)	8	1 <sup>9</sup> / <sub>16</sub> (M30)	5 <sup>7</sup> / <sub>8</sub> (150)	24 <sup>3</sup> / <sub>16</sub> (630)	24 (600)	25 <sup>5</sup> / <sub>16</sub> (650)
42 (1050)	35 <sup>3</sup> / <sub>16</sub> (900)	53 <sup>3</sup> / <sub>8</sub> (1350)	68 <sup>7</sup> / <sub>8</sub> (1750)	8	1 <sup>9</sup> / <sub>16</sub> (M30)	5 <sup>7</sup> / <sub>8</sub> (150)	24 <sup>3</sup> / <sub>16</sub> (630)	28 (700)	29 <sup>1</sup> / <sub>2</sub> (750)
48 (1200)	41 <sup>1</sup> / <sub>8</sub> (1050)	61 (1550)	76 <sup>3</sup> / <sub>4</sub> (1950)	8	1 <sup>7</sup> / <sub>16</sub> (M36)	5 <sup>7</sup> / <sub>8</sub> (150)	31 <sup>1</sup> / <sub>2</sub> (800)	30 (750)	31 <sup>1</sup> / <sub>2</sub> (800)
54 (1350)	45 <sup>1</sup> / <sub>4</sub> (1150)	66 <sup>15</sup> / <sub>16</sub> (1700)	84 <sup>3</sup> / <sub>8</sub> (2150)	8	1 <sup>7</sup> / <sub>16</sub> (M36)	5 <sup>7</sup> / <sub>8</sub> (150)	31 <sup>1</sup> / <sub>2</sub> (800)	32 (800)	33 <sup>3</sup> / <sub>16</sub> (850)
60 (1500)	51 <sup>1</sup> / <sub>8</sub> (1300)	72 <sup>3</sup> / <sub>8</sub> (1850)	90 <sup>9</sup> / <sub>16</sub> (2300)	12	1 <sup>7</sup> / <sub>16</sub> (M36)	5 <sup>7</sup> / <sub>8</sub> (150)	31 <sup>1</sup> / <sub>2</sub> (800)	36 (900)	37 <sup>3</sup> / <sub>8</sub> (950)
64 (1600)	53 <sup>3</sup> / <sub>8</sub> (1350)	76 <sup>3</sup> / <sub>4</sub> (1950)	94 <sup>1</sup> / <sub>2</sub> (2400)	12	1 <sup>7</sup> / <sub>16</sub> (M36)	5 <sup>7</sup> / <sub>8</sub> (150)	31 <sup>1</sup> / <sub>2</sub> (800)	40 (1000)	41 <sup>1</sup> / <sub>8</sub> (1050)
72 (1800)	59 <sup>1</sup> / <sub>8</sub> (1500)	84 <sup>3</sup> / <sub>8</sub> (2150)	102 <sup>3</sup> / <sub>8</sub> (2600)	14	1 <sup>7</sup> / <sub>16</sub> (M36)	5 <sup>7</sup> / <sub>8</sub> (150)	31 <sup>1</sup> / <sub>2</sub> (800)	42 (1050)	43 <sup>3</sup> / <sub>16</sub> (1100)
								44 (1100)	45 <sup>1</sup> / <sub>4</sub> (1150)
								48 (1200)	47 <sup>1</sup> / <sub>4</sub> (1200)
								54 (1350)	53 <sup>3</sup> / <sub>8</sub> (1350)
								60 (1500)	57 <sup>1</sup> / <sub>8</sub> (1450)



**DSC3/DSCA3 Selection**

Project: \_\_\_\_\_ Model: \_\_\_\_\_ Chk'd: \_\_\_\_\_ Date: \_\_\_\_\_

**Pump Total Head**

How to determine total head at a given rated capacity is shown for the simple pumping system in Fig. 1. Since the pump total head is equal to the system head at rated capacity, the pump total head may be obtained from the following equation:

$$\begin{aligned} \text{Pump total head (Ht)} &= H_a + H_d \\ &= H_a + H_{f1} + H_{f2} = H_{f3} \end{aligned}$$

Where,  $H_a$  : static head  
 $H_d$  : hydraulic losses of piping  
 (including residual velocity head)

For dry pit application (DSCA3), hydraulic losses at suction pipe must be included in  $H_d$ .

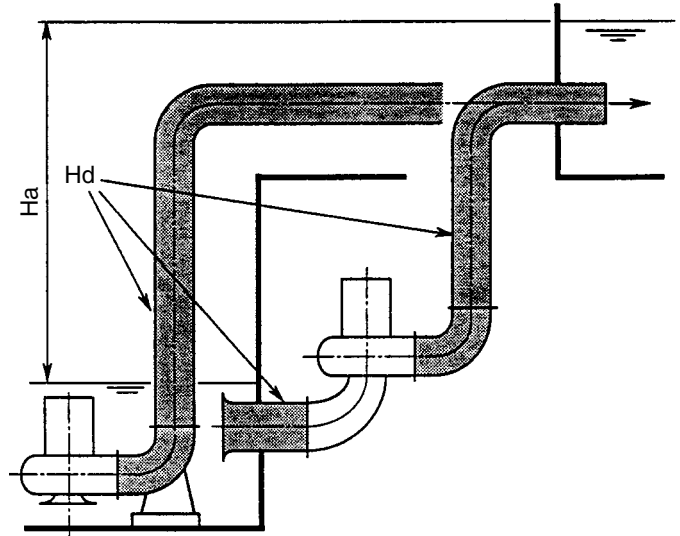

**Fig. 1 PUMP TOTAL HEAD**

**Pump Selection**

In this paragraph, a sample selection of the DSC3/DSCA3 pump is demonstrated by using a simple wet pit case.

**Conditions    Rated Capacity : 5000 GPM**  
 $H_a$ : 70 Ft  
 $H_{f1}$ : 15 Ft

**Step 1 – Selection of pump model**

Assuming a sum of  $H_a$  and  $H_{f1}$  as pump total head, select pump from DSC3/DSCA3 Selection Chart.

In this case, the assumed total head is 85 Ft, and E1152-1770-175HP is selected from the Selection Chart.

From DIMENSIONS, QDC size is  $\phi 10$  inch (250mm) and pump name is 250DSC3.

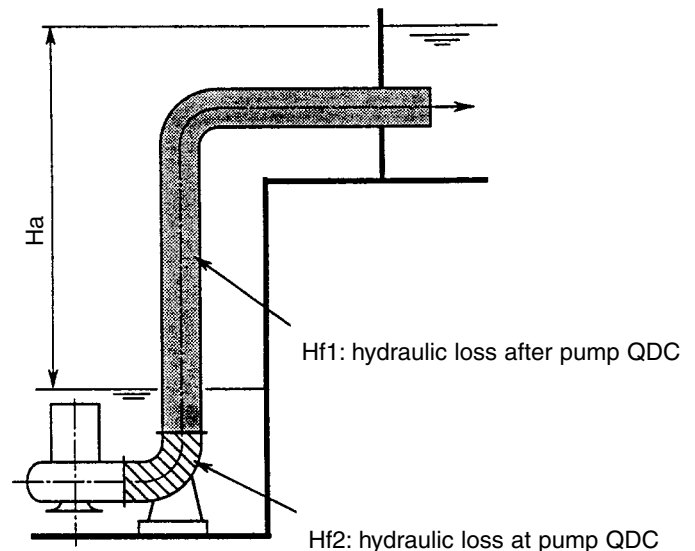

**Fig. 2**

**DSC3/DSCA3 Selection**

---

Project:	Model:	Chk'd:	Date:
----------	--------	--------	-------

---

Hydraulic loss (Hf2) of ø10 inch (250mm) Q.D.C. at rated capacity is 2 Ft from HEAD LOSS AT QDC.

$$H_t = H_a + H_{f1} + H_{f2} = 70 + 15 + 2 = 87 \text{ Ft}$$

At this stage, confirm that  $H_t$  is in the range of the initially selected pump with its performance curve. Refer to HOW TO USE PERFORMANCE CURVE.

**If  $H_t$  is out of the continuous operable range of initially selected pump, repeat with a higher head pump.**

**Step 2 – Motor Rating**

Pump power input (L) can be determined using the following equation:

$$\text{Pump power input (L)} = \frac{Q \times H \times Sp \text{ Gr}}{Ep \times 3960}$$

where,

SP Gr : specific gravity of the pumping liquid (for water,  $r = 1.0$ )

Q : capacity (USGPM)

H : total head (Ft)

Ep : pump efficiency (%)

**Step 3 – Check Items on the Selected Pump**

Check the selected pump for the following items:

- **Pump continuous operation**  
Confirm that the pump continuous operation range based on the system head variation is within the continuous operable range of the performance curve.
- **NPSH**  
NPSH required shall not exceed NPSH available in the continuous pump operation range
- **Motor rating**  
Pump power input shall not exceed motor rating in the pump operation range.
- **Starting method and cable size**  
Check starting method and cable size with the ELECTRICAL DATA.

**DSZ Pump Selection**

Project: \_\_\_\_\_ Model: \_\_\_\_\_ Chk'd: \_\_\_\_\_ Date: \_\_\_\_\_

**PUMP TOTAL HEAD**

How to determine total head at a given rated capacity is shown for the simple pumping system in Fig. 1. Since the pump total head is equal to the system head at rated capacity, the pump total head may be obtained from the following equation:

$$\begin{aligned} \text{Pump total head} &= H_a + H_d \\ &= H_a + H_{f1} + H_{f2} + H_{f3} \end{aligned}$$

- Where,  $H_a$  : static head  
 $H_d$  : dynamic head  
 $H_{f1}$  : column pipe loss  
 $H_{f2}$  : discharge head loss  
 $H_{f3}$  : discharge line friction loss  
 : (including residual velocity head)

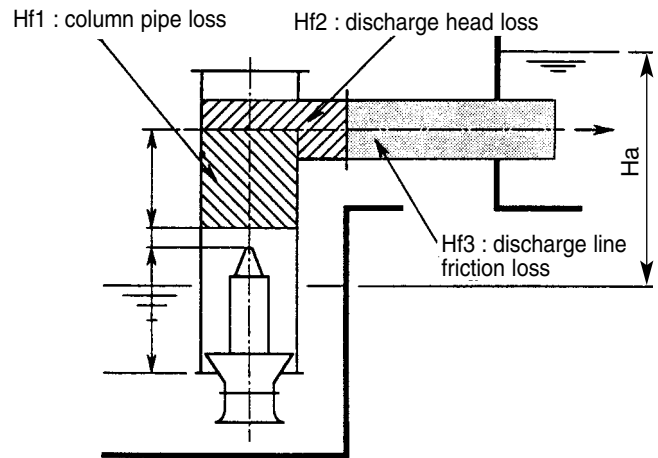

Fig. 1 PUMP TOTAL HEAD

**Please note:** that hydraulic losses up to 20 inches from the top of the pump are included in the pump performance as pump internal losses and are excluded from the system head.

**PUMP SELECTION**

In this paragraph, a sample selection of the DSZ3 pump is demonstrated in four steps based on the following conditions:

- |                        |                         |
|------------------------|-------------------------|
| Conditions             | Rated capacity: 6000GPM |
| $H_a$ :                | 15 ft                   |
| $H_{f3}$ :             | 2 ft                    |
| E:                     | 10 ft                   |
| Discharge nozzle dia.: | 16 inch (400 mm)        |

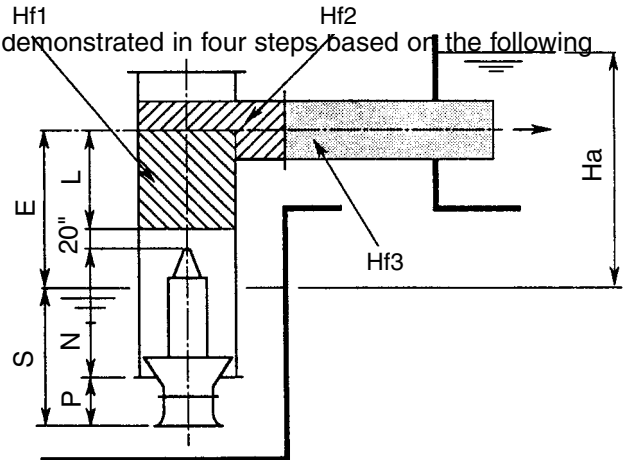

Fig. 2

**DSZ Pump Selection**

Project:

Model:

Chk'd:

Date:

**Step 1 Calculation of Hf1, Hf2 for the initially selected pump**

Assume the pump total head to be the sum of Ha and Hf3, and select a pump from DSZ3 SELECTION CHART.

In this case, with the assumed total head 17 ft (= Ha + Hf3) and rated capacity of 6000 GPM, V0494-1170-40HP can be selected. The following dimensions are from DIMENSIONS.

$$D = 28 \text{ inch (700 mm)} \quad P = 17^{11/16} \text{ inch (450 mm)} \quad N = 59^{1/16} \text{ inch (1500 mm)}$$

On the other hand, minimum submergence S for the pump can be determined from SUBMERGENCE AND CLEARANCE at rated capacity of 6000GPM.

$$S = 30 \text{ inch (760 mm)}$$

**Hf1**

Hf1 can be determined from the following equation:

$$Hf1 = k \times L$$

k is the hydraulic loss of column pipe per unit length and can be determined from PIPE FRICTION LOSS.

In this case, from a column pipe size of 28 inch and a rated capacity of 6000GPM, k is determined as 0.0065 ft/M.

Pipe length L is given as:

$$L = E + S - (P + N + 1.7) = 10 + 2.5 - (1.5 + 4.9 + 1.7) = 4.4 \text{ ft.}$$

Therefore,

$$Hf1 = 0.0065 \times 4.4 \times \frac{1}{3.28} = 0.0087 \text{ ft.}$$

**Hf2**

Hf2 can be determined from the discharge nozzle size "d" and the rated capacity as shown in DISCHARGE HEAD LOSS.

In this case, with rated capacity of 6000GPM and a discharge nozzle size of 16 inch, Hf2 = 1.3 ft is determined.

**DSZ Pump Selection**

Project:

Model:

Chk'd:

Date:

**Step 2 – Total Head**

Using Hf1 and Hf2 as determined in Step 1, Pump total head (Ht) can be obtained from the following equation:

$$H_t = H_a + H_{f1} + H_{f2} + H_{f3} = 15 + 0.0087 + 1.3 + 2 = 18.3087 \text{ ft} \rightarrow H_t = 18.4 \text{ ft}$$

At this stage, confirm that Ht is in the range of the initially selected pump with its performance curve.

Refer to HOW TO USE PERFORMANCE CURVE.

**If Ht is out of the continuous operable range of initially selected pump, repeat from Step 1 with a higher head pump.**

**Step 3 – Motor Rating**

Pump power input (L) can be determined using the following equation:

$$\text{Pump power input (L)} = \frac{Q \times H \times \text{Sp Gr}}{E_p \times 3960}$$

where,

Sp Gr: specific gravity of the pumping liquid (for water, r = 1.0)

Q: capacity (USGPM)

H: total head (Ft)

Ep: pump efficiency (%)

**Step 4 – Check Items on the Selected Pump**

Check the selected pump for the following items.

- **Pump continuous operation range**  
Confirm that the pump continuous operation range based on the system head variation is within the continuous operable range of the performance curve.
- **NPSH**  
NPSH req. shall not exceed NPSH av. in the continuous pump operation range.
- **Motor rating**  
Pump power input shall not exceed motor rating in the pump operation range.
- **Starting method and cable size**  
Check starting method and cable size with ELECTRICAL DATA.