

---

<b>Section</b>	<b>Page</b>
Material Specifications	1-196
Impeller Design Data	1-197
Motor Protection	1-198
Cable Entry	1-199
Paint Specifications	1-200
Mechanical Seal and Ball Bearing Data	1-201
Mechanical Seal Sectional DWG A-15	1-202
Mechanical Seal Sectional DWG A-20 A-30 A-35	1-203
QDC Lifting Chain	1-204
Submergence	1-205
General Information	1-206

---



**Technical Information**

---

Project: \_\_\_\_\_ Model: \_\_\_\_\_ Chk'd: \_\_\_\_\_ Date: \_\_\_\_\_

---

**Material Comparison Table**

<b>MATERIALS</b>	<b>JIS CODE</b>	<b>ASTM, AISI CODE</b>
Cast Iron	G5501, FC20	ASTM A-48 Class 30
420 Stainless	G4303, SUS429J1	AISI 420
304 Stainless Steel	G4303, SUS304	AISI 304
Steel	G3101, SS41	ASTM A283 Grade D
Brass	H3201, BSP3	ASTM B36 No. 272

---

**Technical Information**

Project: \_\_\_\_\_ Model: \_\_\_\_\_ Chk'd: \_\_\_\_\_ Date: \_\_\_\_\_

**Impeller Data**

<b>MODEL</b>	<b>TYPE</b>	<b>DESIGN</b>	<b># VANES</b>	<b>BACK P.O. VANES</b>
50DSU6.4	open	radial	4	no
50DSU6.75	open	radial	3	no
50DSU61.5	open	radial	3	no
50DSU62.2	open	radial	3	yes
50DSU63.7	open	radial	3	yes
80DSU62.2	open	radial	4	yes
80DSU63.7	open	radial	4	yes
100DSU65.5	open	radial	4	yes
100DSU67.5	open	radial	4	yes
50DVSU6.4	open	radial-recessed	6	no
50DVSU6.75	open	radial-recessed	6	no
50DVSU61.5	open	radial-recessed	8	no
80DVSU6.75	open	radial-recessed	6	no
80DVSU61.5	open	radial-recessed	6	no
80DVSU62.2	open	radial-recessed	6	yes
80DVSU63.7	open	radial-recessed	6	yes

**Technical Information**

Project: \_\_\_\_\_ Model: \_\_\_\_\_ Chk'd: \_\_\_\_\_ Date: \_\_\_\_\_

**Motor Protection (Auto-Cut)**

**1. Construction and principles of operation**

There are two different types of Auto-Cuts, one is a single pole model that is used for single phase motors and the other is a three pole model that is used for three phase motors. Figure 1 below illustrates the construction and operation of the three phase model.

Composition: 3 sets of contracts, 1 Snap-Acting Disk, 3 Heaters, 3 Terminals and 1 Calibration bolt and nut.  
The above parts are encased in a Bakelite housing.

**FIGURE 1**

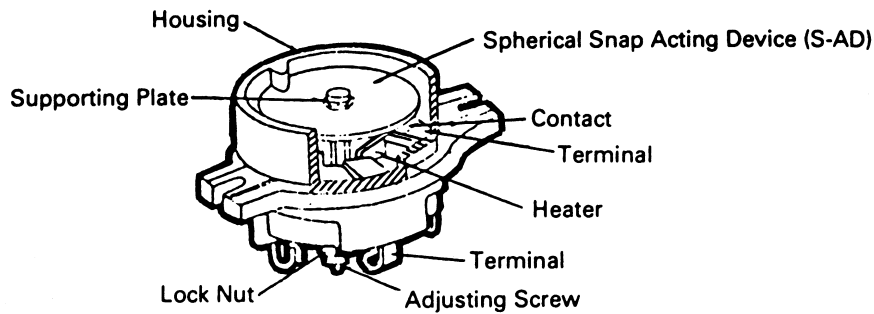

The Auto-Cut is installed directly over the winding of the motor, where it not only senses over heating of the winding but also excess amperage draw by each of the three windings.

Figure 2 shows the Auto-Cut in its normal operating condition (Contacts closed). When actuating temperature is reached, the Snap-Acting Disk snaps open to interrupt the circuits as shown in figure 3.

When the motor temperature cools down to the safe operating temperature, the Snap-Acting Disk resets automatically to the original position as shown in figure 2, and the motor restarts.

**FIGURE 2**

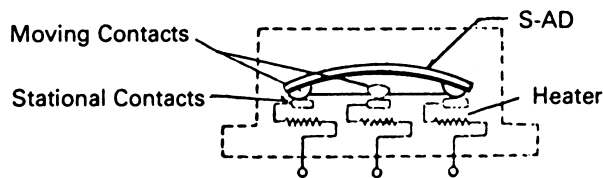

**FIGURE 3**

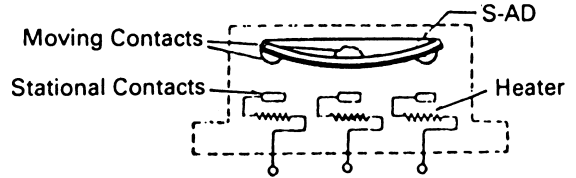

**2. Provides Protection from the Following:**

- Single Phasing
- Low Voltage
- Phase Imbalance
- Locked Rotor
- Run Dry

All of the above conditions will cause the motor protector to actuate.

**Technical Information**

Project: \_\_\_\_\_ Model: \_\_\_\_\_ Chk'd: \_\_\_\_\_ Date: \_\_\_\_\_

**Details of Cable Entry**

Based on its years of experience, EBARA now provides the most dependable cable entry construction of any submersible pump. Its features are as follows:

**Model DSU, DVSU, DSHU, DVSHU**

①	Water cannot leak into motor even if the cable is cut or damaged because cable leads are soldered and then isolated by rubber sealing, thus preventing any capillary action past that point.
②	Thick moulded shoulders bolted to motor dome provide exceptional strength and form a strong compression seal.
③	Cable resists bending forces by increased cable diameter.

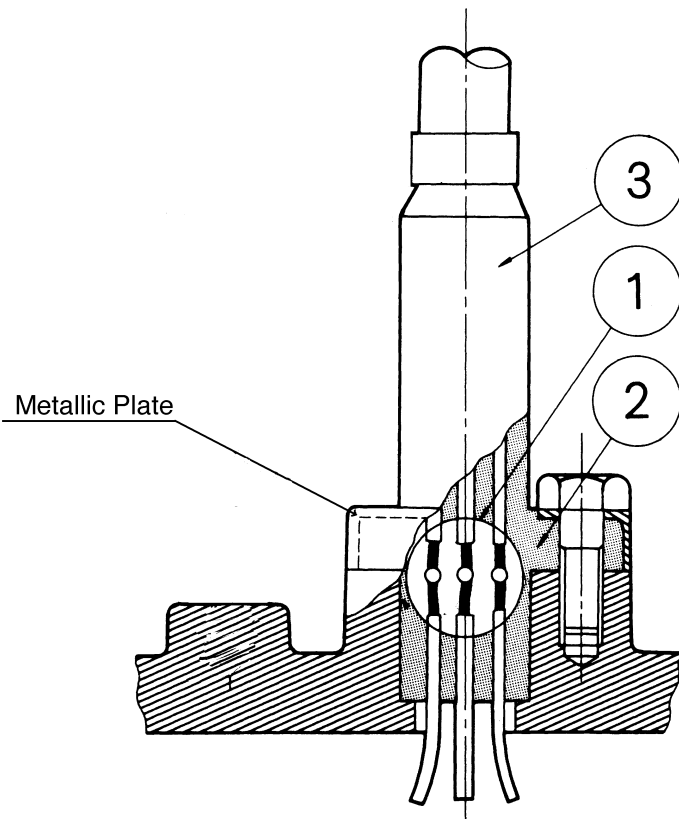

1/2 to 10HP

**Technical Information**

Project: \_\_\_\_\_ Model: \_\_\_\_\_ Chk'd: \_\_\_\_\_ Date: \_\_\_\_\_

**Shop Painting Standards**

**1. Scope**

This specification covers the methods for painting the following EBARA PUMPS in the shop.  
EBARA Models: DSU, DVSU, DSHU, DVSHU

**2. Surface Preparation**

All surfaces to be painted shall be cleaned of oil, grease or other similar materials with solvent, and then shall be brushed and air blasted to remove rust or scale.

Prior to above preparation, mill scale, rust scale, chips and other foreign materials shall be removed in accordance with painting schedule.

**3. Coating Procedure**

Detailed coating procedures are as shown in each paint schedule.

Service	Painting Schedule			
External Surface	Surface Preparation		SPPC-VISI-SP-3-63	
	Coats	Kind of Paint	Brand Name	Maker
	1st	Zinc-chromate primer	ZT-PRIMER	TAIYO PAINT CO., LTD.
	2nd	chlorinated rubber type	KR marine paint primer	KANAE PAINT CO., LTD.

Final color: Black

Service	Painting Schedule			
Internal Surface	Surface Preparation		SPPC-VISI-SP-3-63	
	Coats	Kind of Paint	Brand Name	Maker
	1st	Zinc-chromate primer	ZT-PRIMER	TAIYO PAINT CO., LTD.



**Technical Information**

Project: \_\_\_\_\_ Model: \_\_\_\_\_ Chk'd: \_\_\_\_\_ Date: \_\_\_\_\_

**Mechanical Seal and Ball Bearing**

MODEL	OUTPUT		MECHANICAL SEAL TYPE	LUBRICATING OIL CAPACITY		LUBRICATING OIL NAME	BALL BEARING	
	HP	kW		OZS	CC		BOTTOM	TOP
	DSU	3	2.2	A-30	57	1650	TURBINE OIL SAE 10W or 20W (TURBINE OIL #32)	6307ZZ
DVSU	5	3.7	A-30	57	1650	6308ZZ		6304ZZ
	7½	5.5	A-35	60	1700	6308ZZ		6206ZZ
	10	7.5	A-35	60	1700	6309ZZ		6206ZZ

MODEL	OUTPUT		MECHANICAL SEAL TYPE	LUBRICATING OIL CAPACITY		LUBRICATING OIL NAME	BALL BEARING	
	HP	kW		OZS	CC		BOTTOM	TOP
	DSHU	½	0.4	A-15	6	180	COMPRESSOR OIL SAE 10W or 20W (ROTARY COMPRESSOR) OIL A	6303ZZ
1		0.75	A-15	6	180	6303ZZ		6201ZZ
DVSHU	2	1.5	A-20	12	350	6205ZZ		6203ZZ
	3	2.2	A-30	57	1650	6307ZZ		6304ZZ
	5	3.7	A-30	57	1650	6308ZZ		6304ZZ



**Technical Information**

Project: \_\_\_\_\_ Model: \_\_\_\_\_ Chk'd: \_\_\_\_\_ Date: \_\_\_\_\_

**Mechanical Seal Sectional View (1/2)**

Since the mechanical seal is the most critical part of submersible pumps, EBARA provides the most reliable mechanical seal available for submersible pumps.

DOUBLE MECHANICAL SEALS with HARD seal face materials are provided on all EBARA "D Series" submersible pumps.

The double mechanical seal in oil chamber provides long life and friction-free sealing of the motor shaft.

Typical construction and materials are as follows:

**Type A-15**

**DSHU, 1/2 to 1HP  
DVSHU, 1/2 to 1HP**

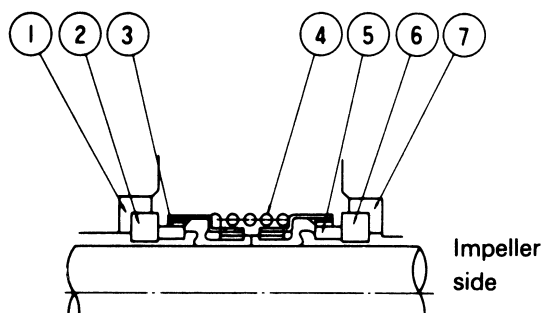

NO.	PART NAME	MATERIALS (HOT WATER PUMP) DSHU, DVSHU	NO. FOR 1 SET
1	Packing	Viton Rubber	1
2	Floating Ring	Silicone Carbide	1
3	Seal Ring	Silicone Carbide	1
4	Spring	304S.S	1
5	Seal Ring	Silicone Carbide	1
6	Floating Ring	Silicone Carbide	1
7	Packing	Viton Rubber	1

**Technical Information**

Project: \_\_\_\_\_ Model: \_\_\_\_\_ Chk'd: \_\_\_\_\_ Date: \_\_\_\_\_

**Mechanical Seal Sectional View (2/2)**

Since the mechanical seal is the most critical part of submersible pumps, EBARA provides the most reliable mechanical seal available for submersible pumps.

DOUBLE MECHANICAL SEALS with HARD seal face materials are provided on all EBARA "D Series" submersible pumps.

The double mechanical seal in oil chamber provides long life and friction-free sealing of the motor shaft.

Typical construction and materials are as follows:

**Type A-20, A-30, A-35**  
**DSU, 2 to 5HP**  
**DSHU, 2 to 5HP**  
**DVSU, 2 to 5HP**  
**DVSHU, 2 to 5HP**

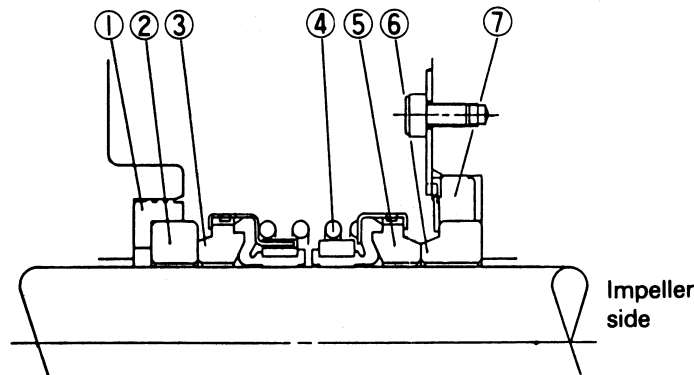

NO.	PART NAME	MATERIALS DSU, DVSU	MATERIALS (HOT WATER PUMP) DSHU, DVSHU	NO. FOR 1 SET
1	Packing	N.B.R. Rubber	Viton Rubber	1
2	Floating	Ceramic	Silicone Carbide	1
3	Seal Ring	Carbon Graphite	Silicone Carbide	1
4	Spring	304 S.S.	304 S.S.	1
5	Seal Ring	Silicone Carbide	Silicone Carbide	1
6	Floating Ring	Silicone Carbide	Silicone Carbide	1
7	Packing	N.B. Rubber	Viton Rubber	1

**Technical Information**

Project: \_\_\_\_\_ Model: \_\_\_\_\_ Chk'd: \_\_\_\_\_ Date: \_\_\_\_\_

**Application of QDC's Lifting Chain**

QDC MODEL	LIFTING CHAIN MODEL	
	MATERIAL : STEEL	MATERIAL : STAINLESS
LS50	LCM-6	LCMS-6
LM65		

STANDARD LENGTHS = 20 FEET

**Technical Information**

Project: \_\_\_\_\_ Model: \_\_\_\_\_ Chk'd: \_\_\_\_\_ Date: \_\_\_\_\_

**Maximum Submergence of Pumps**

EBARA submersible pumps shall be capable of continuous submergence underwater without loss of watertight integrity to the following depths:

MODEL	OPERATION	MAXIMUM SUBMERGENCE
DSU DVSU	Manual Operation	65 Ft.

**Technical Information**

Project: \_\_\_\_\_

Model: \_\_\_\_\_

Chk'd: \_\_\_\_\_

Date: \_\_\_\_\_

**Vortex Pumps — Model DVS**

**1. PRINCIPLES OF VORTEX PUMP**

When the vortex impeller rotates in the casing, it generates primary vortex (B) and secondary vortex (A) as shown in the drawing, and then pumps up water:

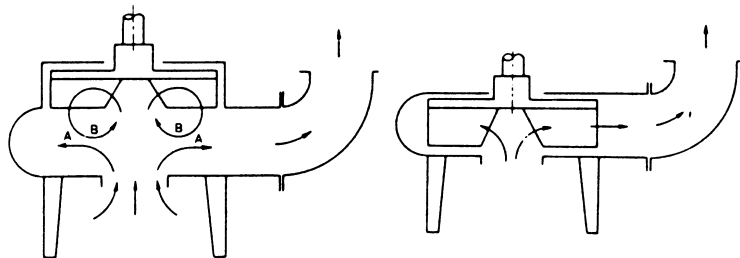

Vortex Pump

ORDINARY NON-CLOG PUMP

**2. FEATURES**

- a) As there is a large space between the impeller and the suction cover and there are no obstacles in the water passage, sewage can be discharged without clogging.
- b) Ebara's unique hydraulic design of impeller and casing provide highly efficient performance which compares favorably with ordinary non-clog pump in spite of the large space.

**Technical Information**

Project: \_\_\_\_\_ Model: \_\_\_\_\_ Chk'd: \_\_\_\_\_ Date: \_\_\_\_\_

**Clogging Phenomena and Prevention**

From abundant experience, EBARA placed the following design conceptions on sump and sewage pumps in order to prevent clogging.

**Clogging Phenomena at:**

**Prevention**

1. Strainer Inlet

Choose a pump with a large strainer opening or pump without strainer, Model DSU

2. Impeller Inlet

Shape inlet portion of the impeller blade as described below. The inlet edge of the impeller vanes are angled toward the impeller periphery so as to facilitate the release of objects that might otherwise clog the pump.

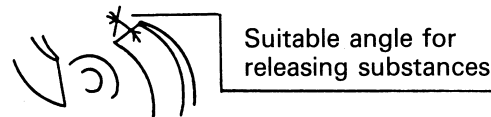

3. Clearance between Impeller and Suction Cover

Increase clearance – for Model DLU or Choose Model DVU.

4. Casing Tongue

Provide large radius on tongue or cut water.

5. Shaft End

Eliminate sharp points on impeller and impeller nut (use rounded impeller nut).

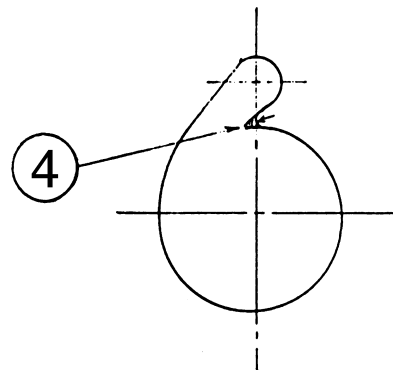
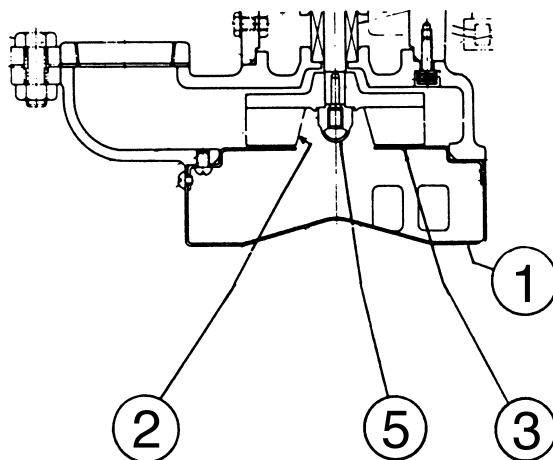

---

**Technical Information**

---

Project:

Model:

Chk'd:

Date:

---

**Understanding Unbalance (1 of 5)**

**Three phase motors can be damaged by sustained application of unbalanced voltages. This problem can easily be more severe than application of balanced voltages above or below normal data plate ratings.**

**Unbalanced Phases**

Unbalanced voltages applied to a 3 phase motor will adversely affect the motor operating characteristics. Motors will operate successfully where the variation in the supply voltage does not exceed plus or minus 10% of the name plate rating, but the voltages of a given 3 phase circuit should be evenly balanced as closely as can be read on the usually available commercial voltmeter. A relatively small unbalance in voltage will cause a considerable increase in temperature rise. For example, a 3.5% voltage unbalance will cause approximately 25% increase in temperature rise. The full load speed is reduced slightly when the motor operates on unbalanced voltages.

An unbalanced voltage will cause unequal currents to flow in the windings. If the motor is moderately or heavily loaded, currents in certain coils will exceed rating and overheat. Thermal cut-outs buried in the windings may detect this overheating and shut down the motor. If not, winding failure will result due to insulation damage.

A second type of damage is caused by rotor heating. This can occur without excessive coil current on a lightly loaded motor. Damaging currents at these frequencies will flow as a result of voltage unbalance. Rotors are not designed for such currents, especially those of recent design optimized by computer techniques. Rotor overheating is most likely to cause bearing or seal failure, again perhaps, after a long period of time. Thermal cut-outs in the stator seldom will detect this problem and starter failures have been charged to mechanical failure while the cause was actually voltage unbalance.

**Unbalanced Currents**

Questions relative to how much unbalance a motor can tolerate have been raised from time to time. This condition is generally due to voltage unbalance in the supply and can usually be corrected by working with the power company involved.

The effect of unbalance phase currents is to increase the heating of the motor and thus reducing its efficiency. Thus it might be said that unbalanced currents as far as motor temperature rise is concerned acts like additional load on the motor. For this reason the permissible loading decreased with increasing unbalance of phase currents.

Before a problem of this nature can be corrected, it is necessary to determine whether the source is with the **submersible motor** or with the **electrical supply furnished for its operation**. The following facts will assist in locating the source of the problem and will govern the steps to be taken in its correction.

Unbalanced amperage is generally caused by problems in either of the following areas:

- A. External power supply, including the pump control box.
- B. Internal problem with motor windings or stator leads to drop cable connection.

**Technical Information**

Project: \_\_\_\_\_ Model: \_\_\_\_\_ Chk'd: \_\_\_\_\_ Date: \_\_\_\_\_

**Understanding Unbalance (2 of 5)**

The following diagrams and explanation will present you with a method by which you can localize the problem as being caused by "A" or by "B". In other words, we are trying to find out whether the trouble lies in the area from the control back through the supply or whether it is a result of malfunction beyond the control down to and including the pump motor.

Assuming that the unit is connected to the supply so that the 3 phase motor is running in the **correct direction of rotation**, there are two other combinations of connection that will change phase connections but not change the rotation. This is accomplished by changing the position of **all three drop** cable leads at their termination in the control. It is important that all three leads be interchanged each time as the interchanging of only two leads will result in reversing the motor. If any two pump cable power leads are interchanged in the control it will change the rotation of the motor. If all three leads are interchanged in the control, the pump will continue to operate in the original rotation.

Once the three power leads in the pump cable are connected to the terminals in the control so that the pump is operating in the correct direction of rotation, there are two other possible combinations that will also operate the pump in the correct direction.

**EXAMPLE**

Assuming that combination #1 is operating in correct rotation the 2nd and 3rd combination will also operate in the correct rotation.

***If combination #1 shows unbalanced amperage readings, it is sometimes possible that one of the other two combinations above will operate at a lesser degree of unbalance.***

Combination	T1	T2	T3
1st →	Red	Black	White
2nd →	Black	White	Red
3rd →	White	Red	Black

**Technical Information**

Project: \_\_\_\_\_ Model: \_\_\_\_\_ Chk'd: \_\_\_\_\_ Date: \_\_\_\_\_

**Understanding Unbalance (3 of 5)**

If the unbalanced leg follows the same wire in the drop cable from the pump, regardless of which position it is connected to on the control terminals the fault would most likely be found in the stator windings or in the stator leads to drop cable connections.

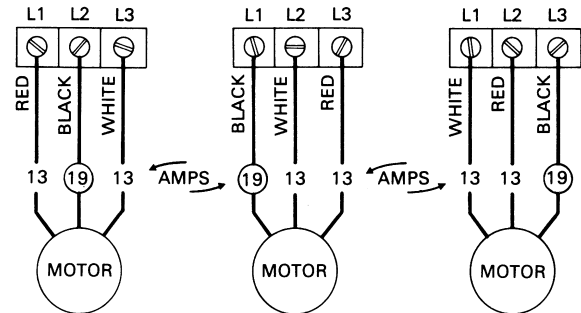

If the unbalanced leg remains related to the same terminal in the control box regardless of which wire is connected to it, the fault would most likely be found in the power supply or possibly poor connection in the control.

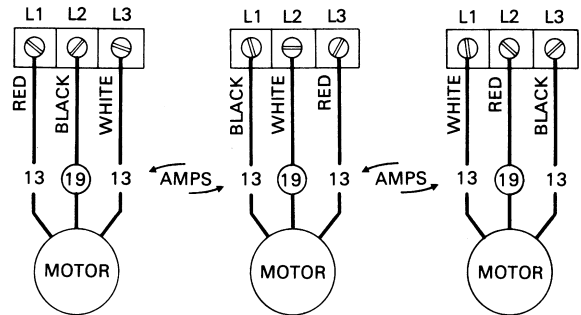

**General Causes of Unbalance**

1. Extreme case as in Single Phasing of a 3 phase supply. The source may be in the control. Either a blown fuse, defective or poor contact point in contactor or any interruption in wiring or terminals.
2. Pulling single phase loads from the 3 phase supply in an unbalanced sequence. This can be especially true in a job shop where electrical load is unpredictable at any given time.

As we are speaking of Voltage and Amperage in terms of percentage of Unbalance, the question arises as to how to figure the % of unbalance in a 3 phase system. The formula reads as follows:

$$\frac{\text{Maximum Deviation from average}}{\text{Average of the 3 readings}} \times 100 = \text{Percentage of Unbalance}$$

**EXAMPLE**

L1—L2 = 234V	Average of the 3 readings: 229
L1—L3 = 230Va	Maximum deviation from the average: 229-223=6V
L2—L3 = 223V	Voltage unbalance : 6/229 x 100 = 2.62%
L1 = 63.3 amps	Average of the 3 readings: 61.1 amps
L2 = 65.6 amps	Maximum deviation from the average: 61.1—54.4=6.7 amps
L3 = 54.4 amps	Amperage unbalance: 6.7/61.1 x 100 = 10.97%

**Technical Information**

Project:

Model:

Chk'd:

Date:

**Understanding Unbalance (4 of 5)**

Maximum permissible % of amperage unbalance allowed at motor full load is 5%. Permissible % of unbalance increases as motor load decreases. However, unless under specific conditions, the motor should, for safety, be considered to be operating at full load.

Maximum permissible % of Voltage unbalance allowed is 1%. Keep in mind that, especially with Delta wound motors, the true amperage unbalance is in the neighborhood of 6 to 10 times the voltage unbalance. The true amperage unbalance is not readily determined by the amperage readings taken in the supply lines. Excess circulating currents within the stator not recorded on your amp meter, contribute to overheating of winding insulation.

The "maximum" percentages mentioned above are based on motors working at full load. Slightly higher maximums may be allowed at less than full load conditions but "good practice" and full warranty must necessarily be based on full load conditions especially with squirrel cage induction motors assigned to such variable conditions as is found in the pumping of liquids, etc.

**Explanation of NEMA Standard MGI-1973-Section 14.34**

This standard presents guidelines on Voltage Unbalance.

While the voltages should be evenly balanced as closely as can be read on the usually available commercial voltmeter, it is recommended that any voltage unbalance at the Motor Terminals not exceed 1%.

Unbalanced Voltage can be broken into two opposing components, a positive sequence voltage and negative sequence voltage component. The positive sequence, operating the motor in its correct rotation, is opposed by the negative sequence, causing a build up of heat.

Unbalance causes extra motor losses and in turn heating of the Rotor and Windings. Increased motor losses increase power costs.

Line currents, as a result of unbalanced voltage, will be greatly unbalanced in the order of 6 to 10 times the voltage unbalance. This true value of the current unbalance will not be apparent on a normal reading as part of the unbalance is in the form of circulating currents in the motor and does not show up in the line. It is recommended that any amperage unbalance at the motor terminals not exceed 5%.

In the phase with the highest current, the percentage increase in temperature rise will be approximately two times the square of the percentage of voltage unbalance.

**EXAMPLE**

If voltage unbalance was 3%, percentage increase in temperature rise would be:

$$2 \times (3\%)^2 = 2 \times 9\% = 18\%$$

**Technical Information**

Project: \_\_\_\_\_ Model: \_\_\_\_\_ Chk'd: \_\_\_\_\_ Date: \_\_\_\_\_

**Understanding Unbalance (5 of 5)**

Any significant voltage unbalance notably reduces the margins that motors have at usual service conditions, i.e. Service Factor. Voltage Unbalance can be more harmful than short time overloading or moderate low voltage conditions.

**Note**

If the unbalance condition cannot be corrected, it would then be advisable to reduce the motor load or oversize the motor.

**Effect of Voltage Variation on Induction Motor Characteristics**

