

**Sectional View**

Project: \_\_\_\_\_ Model: \_\_\_\_\_ Chk'd: \_\_\_\_\_ Date: \_\_\_\_\_

**Single Phase**  
1 to 5HP

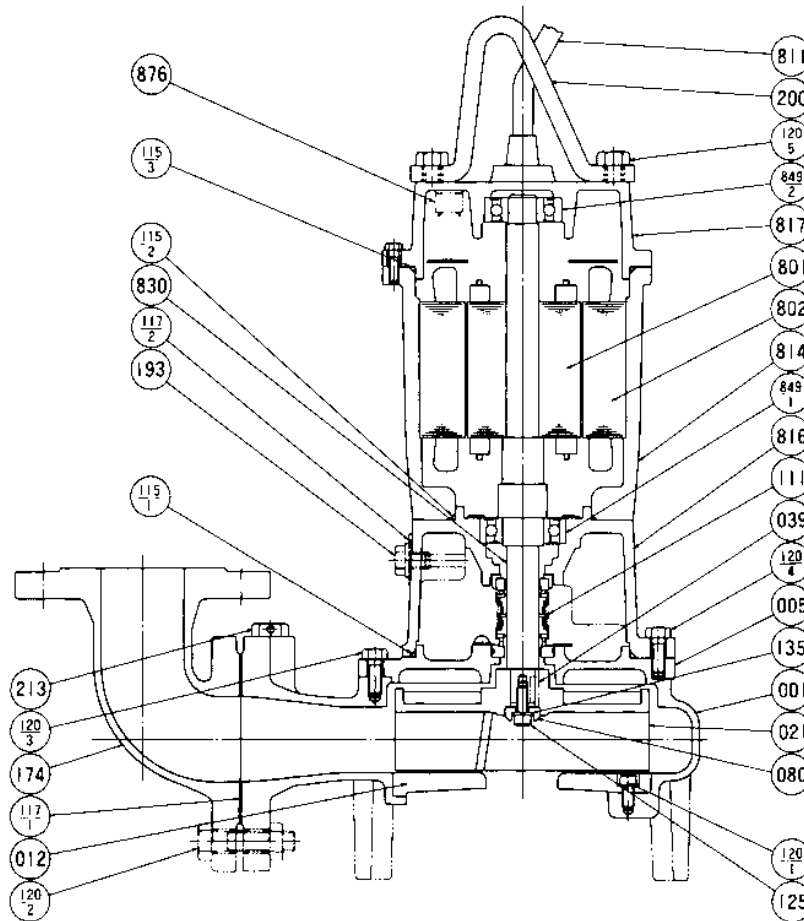

PART NO.	PART NAME	MATERIAL	ASTM, AISI CODE	NO. FOR 1 UNIT	PART NO.	PART NAME	MATERIAL	ASTM, AISI CODE	NO. FOR 1 UNIT
001	CASING	CAST IRON	A48 Class 30	1	125	BOLT	304 STAINLESS	AISI304	1
005	INTERMEDIATE CASING	CAST IRON	A48 Class 30	1	135	WASHER	304 STAINLESS	AISI304	1
012	SUCTION COVER	CAST IRON	A48 Class 30	1	174	DISCHARGE ELBOW	CAST IRON	A48 Class 30	1
021	IMPELLER	CAST IRON	A48 Class 30	1	193	OIL PLUG	316 STAINLESS	AISI316	1
039	KEY	420 STAINLESS	AISI420	1	200	LIFTING HANGER	STEEL	A283 Grade D	1
080	BUSHING	STEEL	A283 Grade D	1	213	AIR VENT VALVE	BRASS	B36 NO. 272	1
†111	MECHANICAL SEAL	—		1 SET	801	ROTOR	—		1
†115-1	O-RING	RUBBER (NBR)		1	802	STATOR	—		1
†115-2	O-RING	RUBBER (NBR)		1	811	SUBMERSIBLE CABLE	—		1
†115-3	O-RING	RUBBER (NBR)		1	814	MOTOR FRAME	CAST IRON	A48 Class 30	1
†117-1	GASKET			1	816	BRACKET	CAST IRON	A48 Class 30	1
†117-2	GASKET			1	817	BRACKET	CAST IRON	A48 Class 30	1
120-1	BOLT	304 STAINLESS	AISI304	3 or 4	830	SHAFT	403 STAINLESS	AISI403	1
120-2	BOLT	304 STAINLESS	AISI304	4	†849-1	BALL BEARING	—		1
120-3	BOLT	304 STAINLESS	AISI304	4 or 8	†849-2	BALL BEARING	—		1
120-4	BOLT	304 STAINLESS	AISI304	4	876	MOTOR PROTECTOR	—		1
120-5	BOLT	304 STAINLESS	AISI304	2					

Motors are purchased as a complete unit.

†: Recommended spare parts.



**Sectional View**

Project:

Model:

Chk'd:

Date:

**Three Phase**  
1 to 2HP

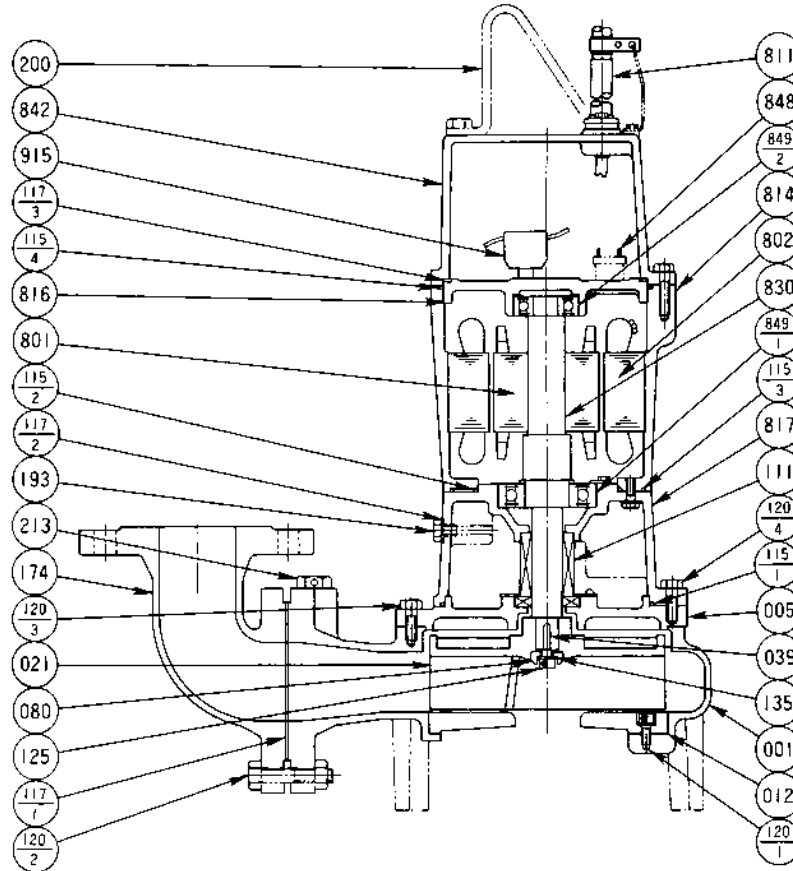

PART NO.	PART NAME	MATERIAL	ASTM, AISI CODE	NO. FOR 1 UNIT
001	CASING	CAST IRON	A48 Class 30	1
005	INTERMEDIATE CASING	CAST IRON	A48 Class 30	1
012	SUCTION COVER	CAST IRON	A48 Class 30	1
021	IMPELLER	CAST IRON	A48 Class 30	1
039	KEY	420 STAINLESS	AISI420	1
080	BUSHING	STEEL	A283 Grade D	1
†111	MECHANICAL SEAL	—		1 SET
†115-1	O-RING	RUBBER (NBR)		1
†115-2	O-RING	RUBBER (NBR)		1
†115-3	O-RING	RUBBER (NBR)		1
†115-4	O-RING	RUBBER (NBR)		1
†117-1	GASKET			1
†117-2	GASKET			1
†117-3	GASKET	RUBBER (NBR)		1
120-1	BOLT	304 STAINLESS	AISI304	3 or 4
120-2	BOLT	304 STAINLESS	AISI304	4
120-3	BOLT	304 STAINLESS	AISI304	4 or 8
120-4	BOLT	304 STAINLESS	AISI304	4

PART NO.	PART NAME	MATERIAL	ASTM, AISI CODE	NO. FOR 1 UNIT
125	BOLT	304 STAINLESS	AISI304	1
135	WASHER	304 STAINLESS	AISI304	1
174	DISCHARGE ELBOW	CAST IRON	A48 Class 30	1
193	OIL PLUG	316 STAINLESS	AISI316	1
200	LIFTING HANGER	STEEL	A283 Grade D	1
213	AIR VENT VALVE	BRASS	B36 NO. 272	1
801	ROTOR	—		1
802	STATOR	—		1
811	SUBMERSIBLE CABLE	—		1
814	MOTOR FRAME	CAST IRON	A48 Class 30	1
816	BRACKET	CAST IRON	A48 Class 30	1
817	BRACKET	CAST IRON	A48 Class 30	1
830	SHAFT	403 STAINLESS	AISI403	1
842	MOTOR COVER	CAST IRON	A48 Class 30	1
848	MOTOR PROTECTOR	—		1
†849-1	BALL BEARING	—		1
†849-2	BALL BEARING	—		1
915	EXTERNAL TERMINAL	—		1

Motors are purchased as a complete unit.  
 Parts No. 115-2 is not installed for 2HP  
 Parts No. 117-3 is not installed for 1HP  
 †: Recommended spare parts.

