

Contents

Model DDLFU

100x80DDLFU611	150x100DDLFU637	200x200DDLFU630
100x80DDLFU615	150x100DDLFU645	200x200DDLFU637
100x80DDLFU618	200x150DDLFU611	200x200DDLFU645
100x80DDLFU622	200x150DDLFU615	250x250DDLFU630
150x100DDLFU611	200x150DDLFU618	250x250DDLFU637
150x100DDLFU615	200x150DDLFU622	250x250DDLFU645
150x100DDLFU618	200x150DDLFU630	300x300DDLFU630
150x100DDLFU622	200x150DDLFU637	300x300DDLFU637
150x100DDLFU630	200x150DDLFU645	300x300DDLFU645

Section	Page
Specifications	2-249
Selection Chart	2-254
Performance Curves	2-255
Outline Drawings	2-268
Sectional View	2-274
Technical Information	2-289.1
material specification	
impeller description	
motor protection	
cable entry	
paint specifications	
mechanical seal	
general	
Motor Data	2-315.1
motor electrical specifications	
cable data	
wiring diagrams	
motor electrical data	

Model Designation

100 × **80** **DDL****F** **U** **6** **11** **2**

SUCTION SIZE – mm

100mm – 4" 250mm – 10"
 150mm – 6" 300mm – 12"
 200mm – 8"

DISCHARGE SIZE – mm

80mm – 3" 200mm – 8"
 100mm – 4" 250mm – 10"
 150mm – 6" 300mm – 12"

MODEL TYPE

DDL**F** – dry pit submersible sewage pump
DDL**F****M** – FM explosion proof designation

GEOGRAPHIC DESIGNATION

U – U.S.A. market

HERTZ

6 – 60

RATED KW

11 – 15HP 30 – 40HP
 15 – 20HP 37 – 50HP
 18 – 25HP 45 – 60HP
 22 – 30HP

PHASE

none – three phase

VOLTAGE

2 – 208/230
 4 – 460
 5 – 575



Specifications

	Standard	Optional
Size	4"x3", 6"x4", 8"x6", 8"x8", 10"x10", 12"x12"	
Range of HP Range of Performance	15 to 60 HP Capacity 80 to 4000 GPM Head 20 to 243 feet	
Limitation Maximum Water Temperature	104°F (40°C)	
Speed	1800 RPM	
Materials Casing Impeller Shaft Motor Frame Fastener	Cast Iron Cast Iron 420 Stainless Steel Cast Iron 304 Stainless Steel	
Mechanical Seal Material – Upper Side Material – Lower Side Impeller Type Bearing Motor Three Phase Motor Protection	Double Mechanical Seal – Tandem Arrangement Carbon/Ceramic Silicon Carbide/Silicon Carbide Tungsten Carbide/Tungsten Carbide (200 x 150DDLFU and greater, 50 & 60 HP only) Semi-open for 15 to 30 HP Enclosed for 40 to 60HP Prelubricated Ball Bearing Insulation Class F 208/230V, 460V Built-in Thermal Detector – Klixon Built-in Mechanical Seal Leakage Detector – Float Switch Submersible cable 40 ft.	Tungsten Carbide/Tungsten Carbide Tungsten Carbide/Tungsten Carbide FM Explosion Proof, Class 1, Division 1, Group C, D ____ ft. (customer specified)

Specifications

A. General:

Provide dry pit submersible sewage pumps suitable for continuous duty operation underwater without loss of water tight integrity to a depth of 65 feet. Pump system design shall include permanently mounted suction elbow on which the pump/motor unit is mounted. The motor and pump shall be designed, manufactured, and assembled by the same manufacturer.

B. Manufacturer:

EBARA International Corporation

C. Pump Characteristics:

Pumps shall conform to the following requirements:

Number of units	
Design flow (gpm)	
Design TDH (ft)	
Minimum shut off head (ft)	
RPM	1800
Maximum HP	
Minimum efficiency at design (%)	
Minimum power factor at design (%)	
Voltage/HZ	208/230V, 460V / 60
Phase	3

D. Pump Construction:

All major parts of the pumping unit(s) including casing, impeller, suction cover, wear rings, motor frame, suction and discharge elbows shall be manufactured from gray cast iron, ASTM A-48 Class 30. Castings shall have smooth surfaces devoid of blow holes or other casting irregularities. Casing design shall be centerline discharge with a large radius on the cut water to prevent clogging. Units shall be furnished with a discharge elbow and 125 lb. flat face ANSI flange. The suction elbow shall include a hand clean-out port. All exposed bolts and nuts shall be 304 stainless steel. All mating surfaces of major components shall be machined and fitted with NBR O-rings where watertight sealing is required. Machining and fitting shall be such that sealing is accomplished by automatic compression of O-rings in two planes and O-ring contact is made on four surfaces without the requirement of specific torque limits. Internal and external surfaces are prepared to SPPC-VISI-SP-3-63 then coated with a zinc-chromate primer. The external surfaces are then coated with an H.B. Tnemecol 46-465 Coal Tar paint

1. Impellers:

- a. For units 15 to 30 HP, the impeller shall be a mixed flow multi-vane semi-open design. It shall be dynamically balanced and shall be designed for solids handling with a long thrulet without acute turns. The inlet edge of the impeller vanes shall be angled toward the impeller periphery so as to facilitate the release of objects that might otherwise clog the pump. The 15 to 30 HP impeller design shall also include back pump out vanes to reduce the pressure and entry of foreign materials into the mechanical seal area. In addition, a lip seal shall be located behind the impeller hub to further reduce the entry of foreign materials into the seal area. Impellers shall be direct connected to the motor shaft with a slip fit, key driven, and secured with an impeller bolt. The design shall include a replaceable cast iron suction cover. The suction cover shall be designed such that it may be adjusted to maintain working clearances and hydraulic efficiencies.
- b. For high head units, 4" discharge, 40 to 60 HP shall have a radial multi-vane, enclosed impeller design. It shall be dynamically balanced and shall be designed for solids handling with a long thrulet without acute turns. The inlet edge of the impeller vanes shall be angled toward the impeller periphery so as to facilitate the release of objects that might otherwise clog the pump. A lip seal shall be located behind the impeller hub to reduce the entry of foreign materials into the mechanical seal area. Impellers shall be direct connected to the motor shaft with a slip fit, key driven, and secured with an impeller bolt. The design shall include a replaceable casing wear ring at the pump suction to maintain working clearances and hydraulic efficiencies.

Specifications

- c. For units 6" to 12" discharge sizes, 40 to 60 HP, the impeller shall be a mixed flow multi-vane enclosed design. It shall be dynamically balanced and shall be designed for solids handling with a long thrulet without acute turns. The inlet edge of the impeller vanes shall be angled toward the impeller periphery so as to facilitate the release of objects that might otherwise clog the pump. A lip seal shall be located behind the impeller hub to reduce the entry of foreign materials into the seal area. Impellers shall be direct connected to the motor shaft with a slip fit, key driven, and secured with an impeller bolt. The design shall include replaceable upper and lower case rings to maintain working clearances and hydraulic efficiencies.

2. Mechanical Seals:

Pumps shall be designed to include a double mechanical seal in a tandem arrangement. Each seal shall be positively driven and act independently with its own spring system. The upper seal operates in an oil bath, while the lower seal is lubricated by the oil from between the shaft and the seal faces, and in contact with the pumpage. The oil filled seal chamber shall be designed to prevent over-filling and include an anti-vortexing vane to insure proper lubrication of both seal faces. Lower face materials shall be silicon carbide (tungsten carbide for 150 to 300DLF 50 and 60 HP only), upper faces carbon vs. ceramic, NBR elastomers, and 304SS hardware. Seal system shall not rely on pumping medium for lubrication.

E. Motor Construction:

The pump motor shall be an air filled induction type with a squirrel cage rotor, shell type design, built to NEMA MG-1, Design B specifications. Stator windings shall be copper, insulated with moisture resistant Class F insulation, rated for 311°F. The stator shall be dipped and baked three times in Class F varnish and heat shrunk fitted into the stator housing. Rotor bars and short circuit rings shall be manufactured of cast aluminum. Motor shaft shall be one piece AISI420 material, rotating on two permanently lubricated ball bearings designed for a minimum B-10 life of 60,000 hours. Motor service factor shall be 1.15 and capable of up to 20 starts per hour. The motor shall be designed for continuous duty pumping at a maximum sump temperature of 104°F. Voltage and frequency tolerances shall be a maximum 10 / 5% respectively. Motor over temperature protection shall be provided by miniature thermal protectors embedded in the windings. Mechanical seal failure protection shall be provided by a mechanical float switch located in a chamber above the seal. This switch shall be comprised of a magnetic float that actuates a dry reed switch encapsulated within the stem. Should the mechanical seal fail, liquid shall be directed into the float chamber, in which the rising liquid activates the switch opening the normally closed circuit. For units 15 to 30 HP the float body and float shall be a polypropylene material. Units 40 HP and greater, the float switch components shall be 304SS. The motor shall be non-overloading over the entire specified range of operation.

The motor design shall also include an integral cooling jacket constructed of steel, A283, Grade D. The cooling medium shall be the pumpage. Re-circulation through the jacket shall be achieved by discharging the pumpage into the cooling jacket from the periphery, high pressure area, of the impeller, and returning it into the low pressure behind the impeller, at the hub. The cooling passageways shall be non-clogging by virtue of the dimensions; screening solids from entering the jacket. The jacket shall have external NPT connections to be used for external cooling as an option, as well as for venting the jacket. The jacket cooling system shall provide heat dissipation for the motor whether the unit is submerged or operating in air.

The power cable jacket shall be manufactured of an oil resistant chloroprene rubber material, designed for submerged applications. Cable shall be watertight to a depth of at least 65'. The cable entry system shall comprise of primary, secondary, and tertiary sealing methods. The primary seal shall be achieved by a cylindrical elastomeric grommet compressed between the motor cover and a 304SS washer. Secondary sealing is accomplished with a compressed O-ring made of NBR material. Compression and subsequent sealing shall preclude specific torque requirements. The system shall also include tertiary sealing to prevent leakage into the motor housing due to capillary action through the insulation if the cable is damaged or cut. The cable wires shall be cut, stripped, re-connected with a copper butt end connector, and embedded in epoxy within the cable gland. This provides a dead end for leakage through the cable insulation into the motor junction area. The cable entry system shall be the same for both the power and control cables.

Specifications

A. General:

Provide FM explosion proof dry pit submersible sewage pumps suitable for continuous duty operation underwater without loss of watertight integrity to a depth of 65 feet. Pump system design shall include permanently mounted suction elbow on which the pump/motor unit is mounted. The motor and pump shall be designed, manufactured, and assembled by the same manufacturer.

B. Manufacturer:

EBARA International Corporation

C. Pump Characteristics:

Pumps shall conform to the following requirements:

Number of units	
Design flow (gpm)	
Design TDH (ft)	
Minimum shut off head (ft)	
RPM	1800
Maximum HP	
Minimum efficiency at design (%)	
Minimum power factor at design (%)	
Voltage/HZ	208/230V, 460V / 60
Phase	3

D. Pump Construction:

All major parts of the pumping unit(s) including casing, impeller, suction cover, wear rings, motor frame, suction and discharge elbows shall be manufactured from gray cast iron, ASTM A-48 Class 30. Castings shall have smooth surfaces devoid of blow holes or other casting irregularities. Casing design shall be centerline discharge with a large radius on the cut water to prevent clogging. Units shall be furnished with a discharge elbow and 125 lb. flat face ANSI flange. The suction elbow shall include a hand clean-out port. All exposed bolts and nuts shall be 304 stainless steel. All mating surfaces of major components shall be machined and fitted with NBR O-rings where watertight sealing is required. Machining and fitting shall be such that sealing is accomplished by automatic compression of O-rings in two planes and O-ring contact is made on four surfaces without the requirement of specific torque limits. Internal and external surfaces are prepared to SPPC-VISI-SP-3-63 then coated with a zinc-chromate primer. The external surfaces are then coated with an H.B. Tnemecol 465 Coal Tar paint.

1. Impellers:

- a. For units 15 to 30 HP, the impeller shall be a mixed flow multi-vane semi-open design. It shall be dynamically balanced and shall be designed for solids handling with a long thrulet without acute turns. The inlet edge of the impeller vanes shall be angled toward the impeller periphery so as to facilitate the release of objects that might otherwise clog the pump. The 15 to 30 HP impeller design shall also include back pump out vanes to reduce the pressure and entry of foreign materials into the mechanical seal area. In addition, a lip seal shall be located behind the impeller hub to further reduce the entry of foreign materials into the seal area. Impellers shall be direct connected to the motor shaft with a slip fit, key driven, and secured with an impeller bolt. The design shall include a replaceable cast iron suction cover. The suction cover shall be designed such that it may be adjusted to maintain working clearances and hydraulic efficiencies.
- b. For high head, 4" units, 4" discharge, 40 to 60 HP shall have a radial multi-vane, enclosed impeller design. It shall be dynamically balanced and shall be designed for solids handling with a long thrulet without acute turns. The inlet edge of the impeller vanes shall be angled toward the impeller periphery so as to facilitate the release of objects that might otherwise clog the pump. A lip seal shall be located behind the impeller hub to reduce the entry of foreign materials into the mechanical seal area. Impellers shall be direct connected to the motor shaft with a slip fit, key driven, and secured with an impeller bolt. The design shall include a replaceable casing wear ring at the pump suction to maintain working clearances and hydraulic efficiencies.



Specifications

- c. For units 6" to 12" discharge sizes, 40 to 60 HP, the impeller shall be a mixed flow multi-vane enclosed design. It shall be dynamically balanced and shall be designed for solids handling with a long thrulet without acute turns. The inlet edge of the impeller vanes shall be angled toward the impeller periphery so as to facilitate the release of objects that might otherwise clog the pump. A lip seal shall be located behind the impeller hub to reduce the entry of foreign materials into the seal area. Impellers shall be direct connected to the motor shaft with a slip fit, key driven, and secured with an impeller bolt. The design shall include replaceable upper and lower case rings to maintain working clearances and hydraulic efficiencies.

2. Mechanical Seals:

Pumps shall be designed to include a double mechanical seal in a tandem arrangement. Each seal shall be positively driven and act independently with its own spring system. The upper seal operates in an oil bath, while the lower seal is lubricated by the oil from between the shaft and the seal faces, and in contact with the pumpage. The oil filled seal chamber shall be designed to prevent over-filling and include an anti-vortexing vane to insure proper lubrication of both seal faces. Lower face materials shall be silicon carbide (tungsten carbide for 150 to 300 DLFU 50 and 60 HP only), upper faces carbon vs. ceramic, NBR elastomers, and 304SS hardware. Seal system shall not rely on pumping medium for lubrication.

E. Motor Construction:

The pump motor shall be FM Explosion Proof, Class 1, Division 1, Groups C, D. The design shall be an air filled induction type with a squirrel cage rotor, shell type design, built to NEMA MG-1, Design B specifications. Stator windings shall be copper, insulated with moisture resistant Class F insulation, rated for 311°F. The stator shall be dipped and baked three times in Class F varnish and heat shrunk fitted into the stator housing. Rotor bars and short circuit rings shall be manufactured of cast aluminum. Motor shaft shall be one piece AISI420 material, rotating on two permanently lubricated ball bearings designed for a minimum B-10 life of 60,000 hours. Motor service factor shall be 1.15 and capable of up to 20 starts per hour. The motor shall be designed for continuous duty pumping at a maximum sump temperature of 104°F. Voltage and frequency tolerances shall be a maximum 10 / 5% respectively. Motor over temperature protection shall be provided by miniature thermal protectors embedded in the windings. Mechanical seal failure protection shall be provided by a mechanical float switch located in a chamber above the seal. This switch shall be comprised of a magnetic float that actuates a dry reed switch encapsulated within the stem. Should the mechanical seal fail, liquid shall be directed into the float chamber, in which the rising liquid activates the switch opening the normally closed circuit. For units 15 to 30 HP the float body and float shall be a polypropylene material. Units 40 HP and greater, the float switch components shall be 304SS. The motor shall be non-overloading over the entire specified range of operation.

The motor design shall also include an integral cooling jacket constructed of steel, A283, Grade D. The cooling medium shall be the pumpage. Re-circulation through the jacket shall be achieved by discharging the pumpage into the cooling jacket from the periphery, high pressure area, of the impeller, and returning it into the low pressure behind the impeller, at the hub. The cooling passage ways shall be non-clogging by virtue of the dimensions; screening solids from entering the jacket. The jacket shall have external NPT connections to be used for external cooling as an option, as well as for venting the jacket. The jacket cooling system shall provide heat dissipation for the motor whether the unit is submerged or operating in air.

The power cable jacket shall be manufactured of an oil resistant chloroprene rubber material, designed for submerged applications. Cable shall be watertight to a depth of at least 65'. The cable entry system shall comprise of primary, secondary, and tertiary sealing methods. The primary seal shall be achieved by a cylindrical elastomeric grommet compressed between the motor cover and a 304SS washer. Secondary sealing is accomplished with a compressed O-ring made of NBR material. Compression and subsequent sealing shall preclude specific torque requirements. The system shall also include tertiary sealing to prevent leakage into the motor housing due to capillary action through the insulation if the cable is damaged or cut. The cable wires shall be cut, stripped, re-connected with a copper butt end connector, and embedded in epoxy within the cable gland. This provides a dead end for leakage through the cable insulation into the motor junction area. The cable entry system shall be the same for both the power and control cables.

Selection Chart

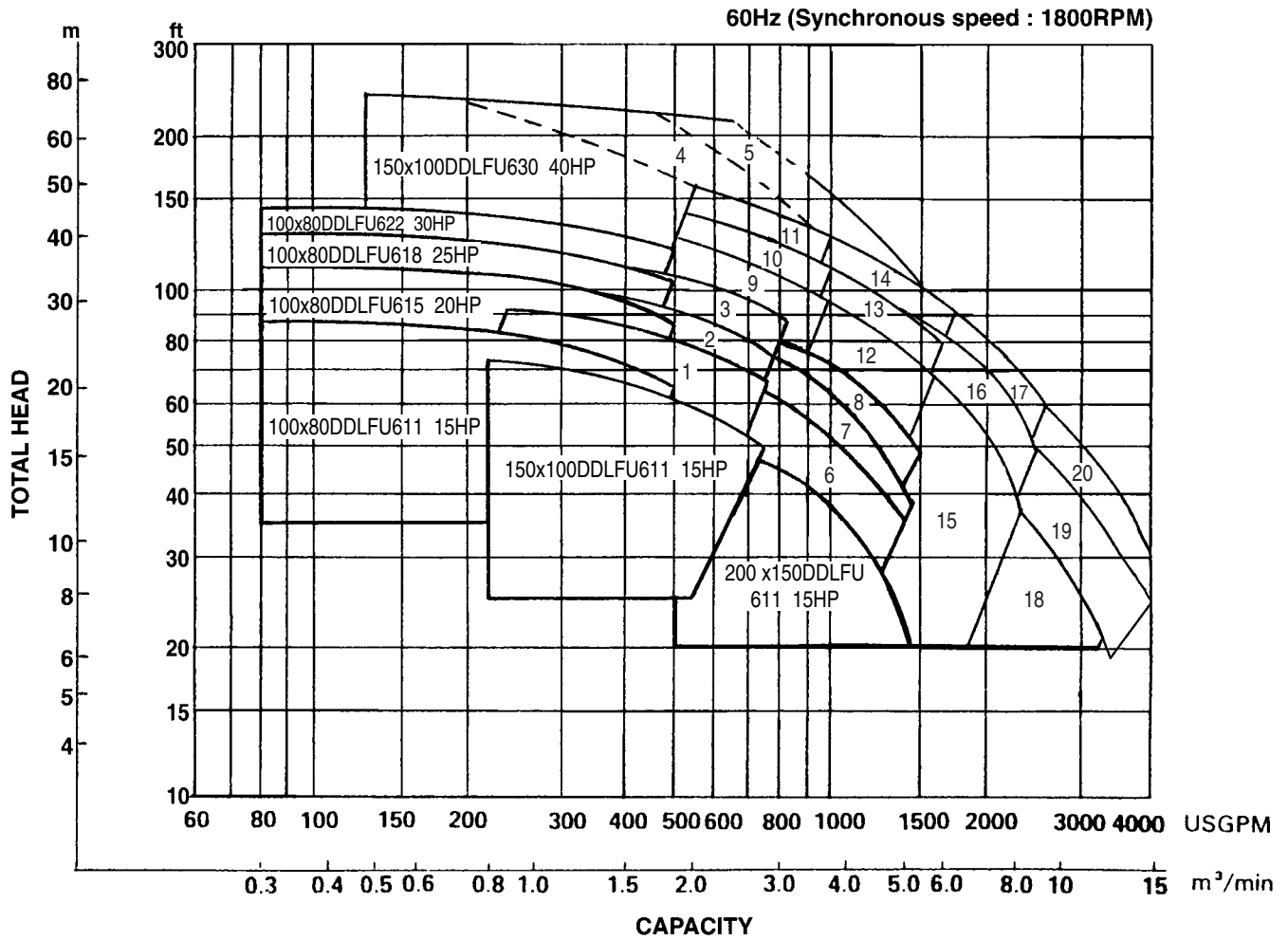

1	150x100DDLFU615 20HP	9	200x150DDLFU630 40HP	17	250x250DDLFU645 60HP
2	150x100DDLFU618 25HP	10	200x150DDLFU637 50HP	18	300x300DDLFU630 40HP
3	150x100DDLFU622 30HP	11	200x150DDLFU645 60HP	19	300x300DDLFU637 50HP
4	150x100DDLFU637 50HP	12	200x200DDLFU630 40HP	20	300x300DDLFU645 60HP
5	150x100DDLFU645 60HP	13	200x200DDLFU637 50HP		
6	200x150DDLFU615 20HP	14	200x200DDLFU645 60HP		
7	200x150DDLFU618 25HP	15	250x250DDLFU630 40HP		
8	200x150DDLFU622 30HP	16	250x250DDLFU637 50HP		



Performance Curves

Project: _____ GPM: _____ TDH: _____ EFF: _____ HP: _____ Chk'd: _____ Date: _____

100x80DDL611 (15HP) Synchronous Speed: 1800 RPM 4 inch suction 3 inch Discharge

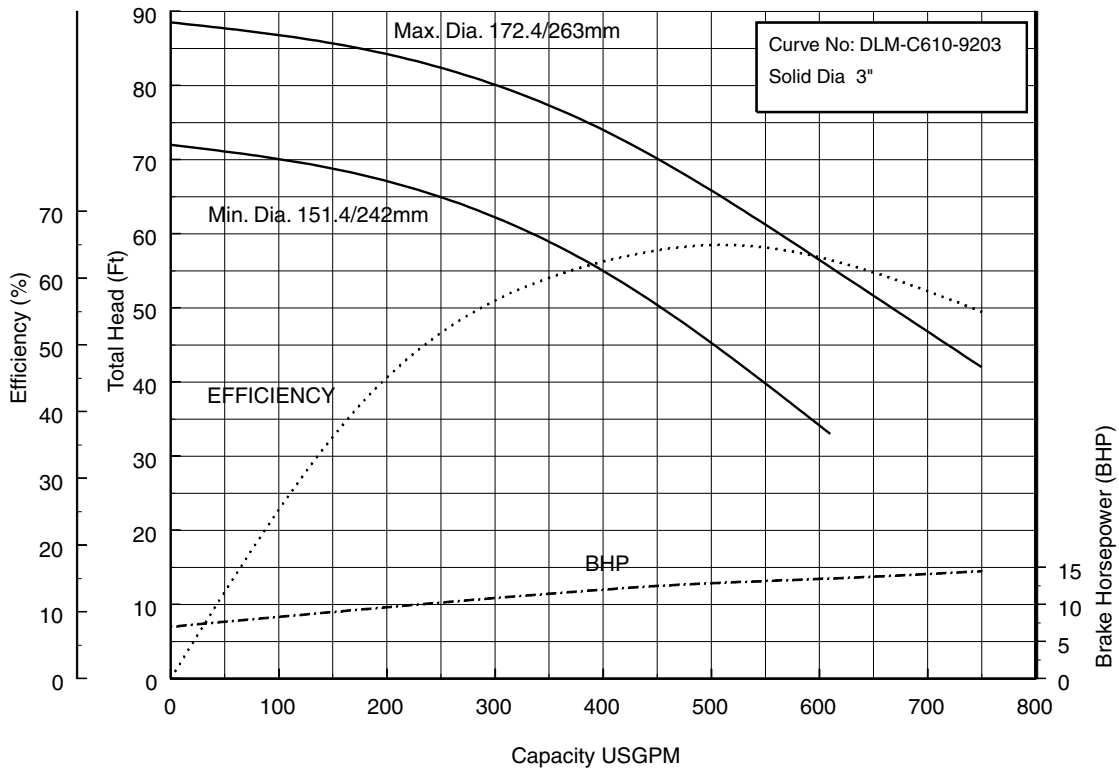

100x80DDL615 (20HP) Synchronous Speed: 1800 RPM 4 inch suction 3 inch Discharge

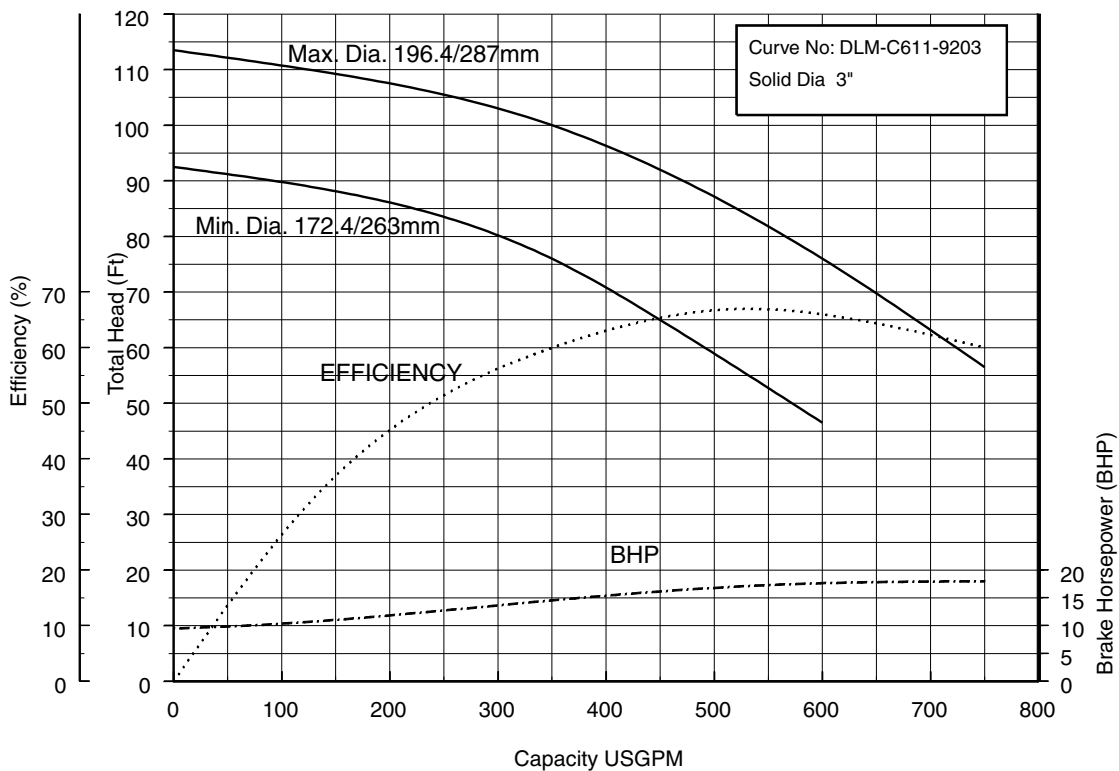

Performance Curves

Project: _____ GPM: _____ TDH: _____ EFF: _____ HP: _____ Chk'd: _____ Date: _____

100x80DDL618 (25HP) Synchronous Speed: 1800 RPM 4 inch Suction 3 inch Discharge

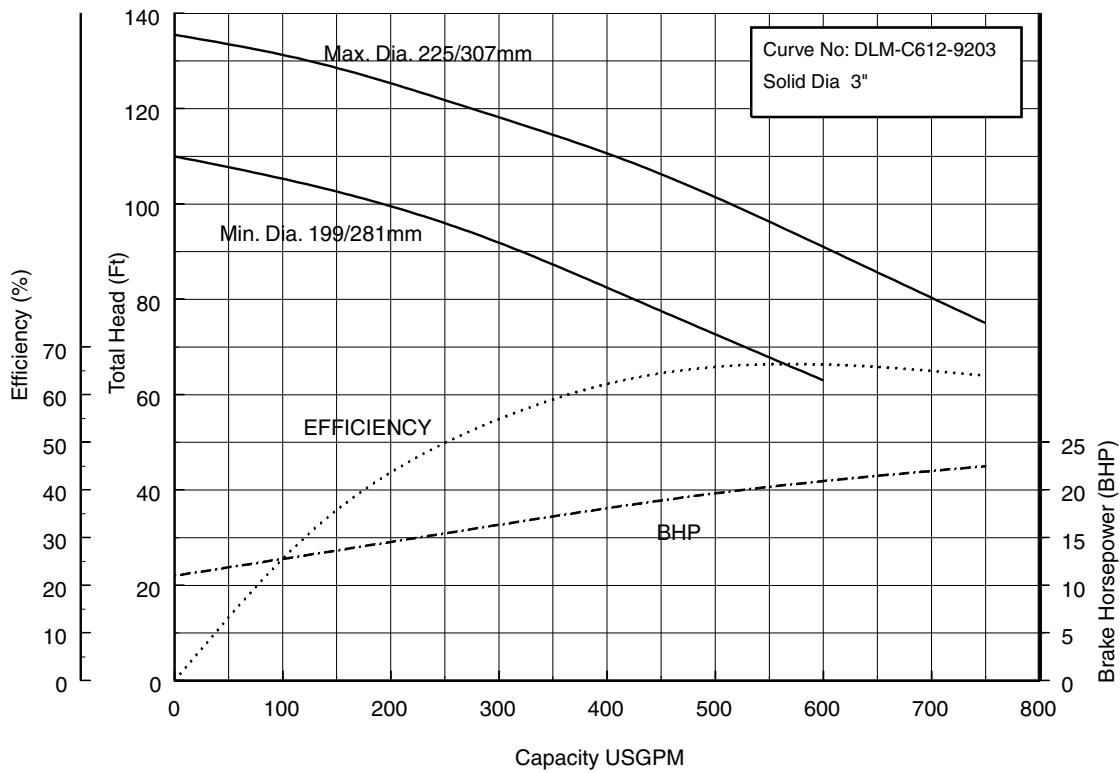

100x80DDL622 (30HP) Synchronous Speed: 1800 RPM 4 inch Suction 3 inch Discharge

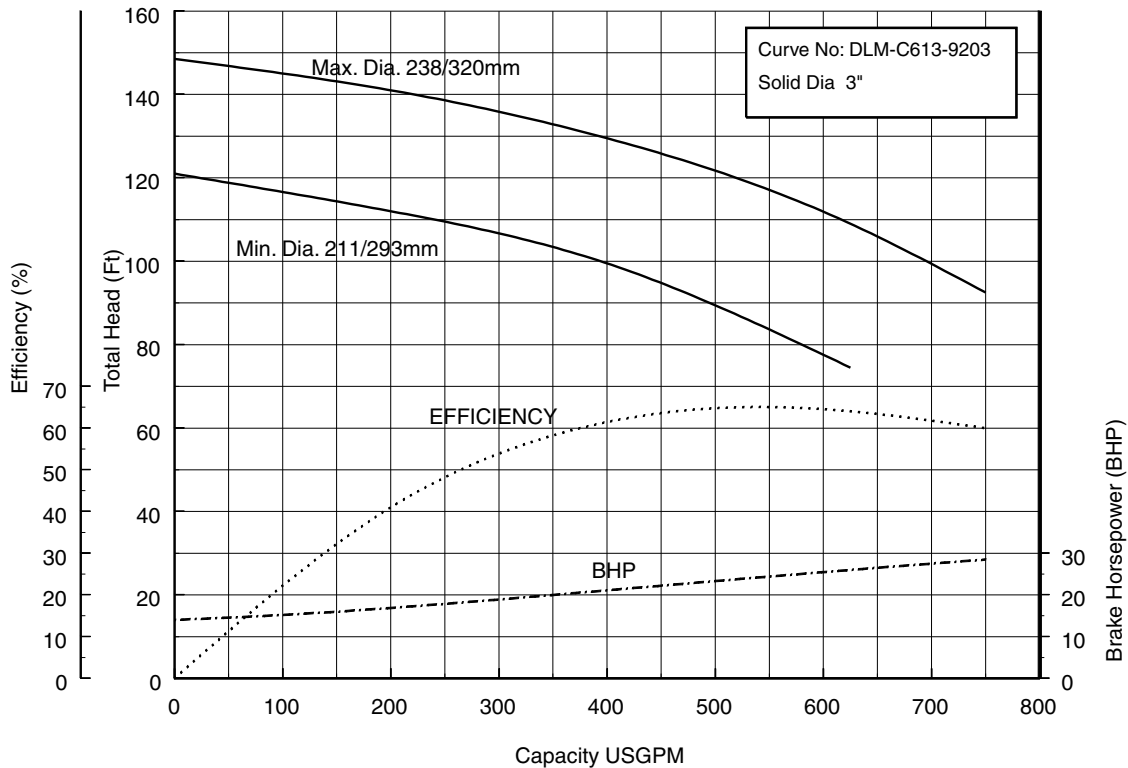

Performance Curves

Project: _____ GPM: _____ TDH: _____ EFF: _____ HP: _____ Chk'd: _____ Date: _____

150x100DDL611 (15HP) Synchronous Speed: 1800 RPM 6 inch suction 4 inch Discharge

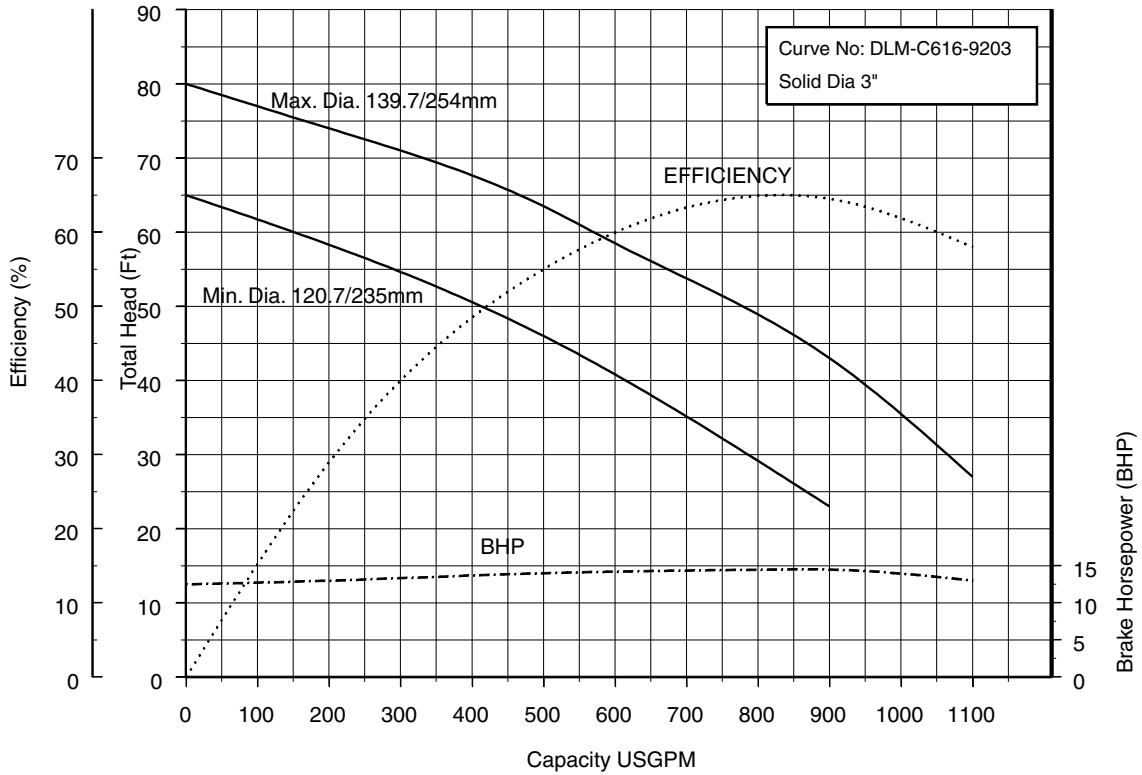

150x100DDL615 (20HP) Synchronous Speed: 1800 RPM 6 inch Suction 4 inch Discharge

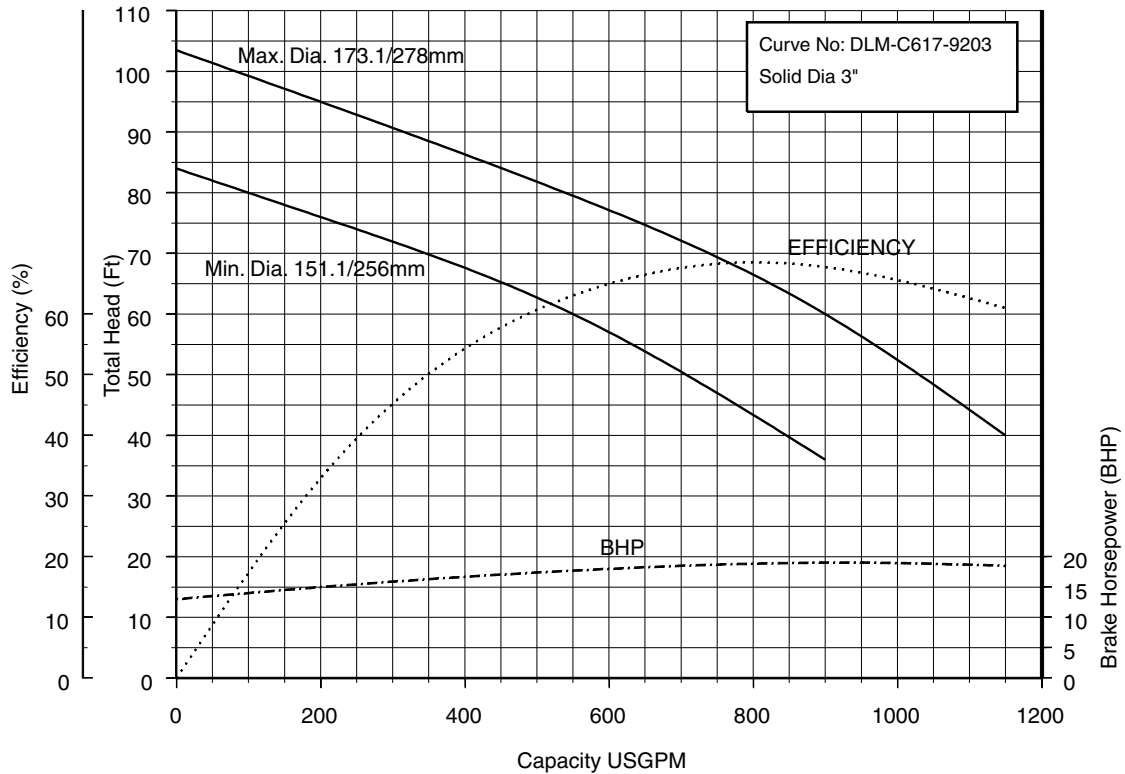

Performance Curves

Project: _____ GPM: _____ TDH: _____ EFF: _____ HP: _____ Chk'd: _____ Date: _____

150x100DDL F618 (25HP) Synchronous Speed: 1800 RPM 6 inch Suction 4 inch Discharge

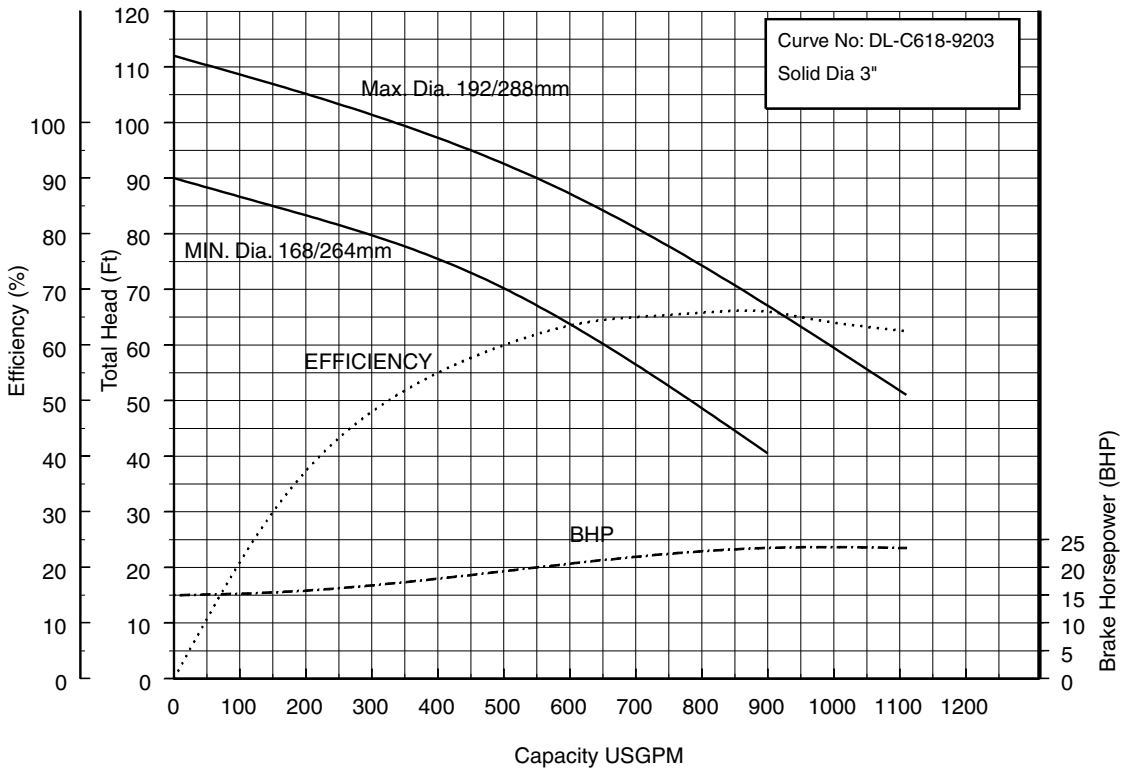

150x100DDL F622 (30HP) Synchronous Speed: 1800 RPM 6 inch Suction 4 inch Discharge

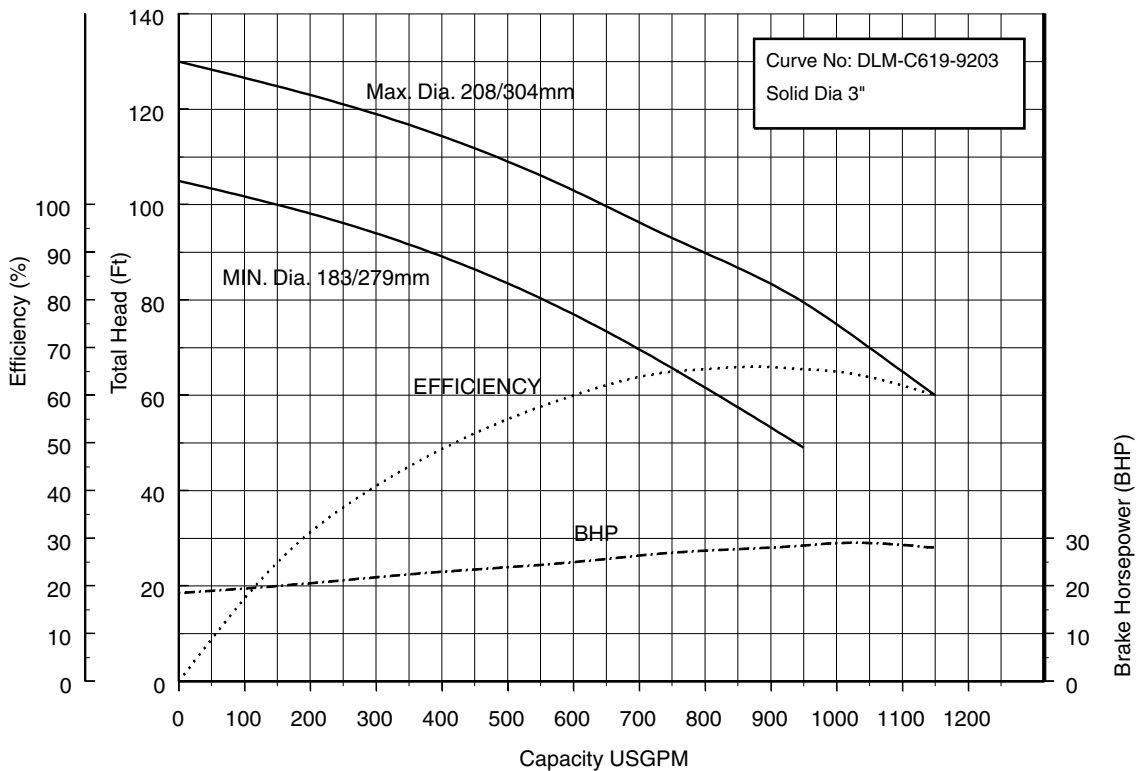

Performance Curves

Project: _____ GPM: _____ TDH: _____ EFF: _____ HP: _____ Chk'd: _____ Date: _____

150x100DDL630 to 645 (40 to 60HP) Synchronous Speed: 1800 RPM 6 inch Suction 4 inch Discharge

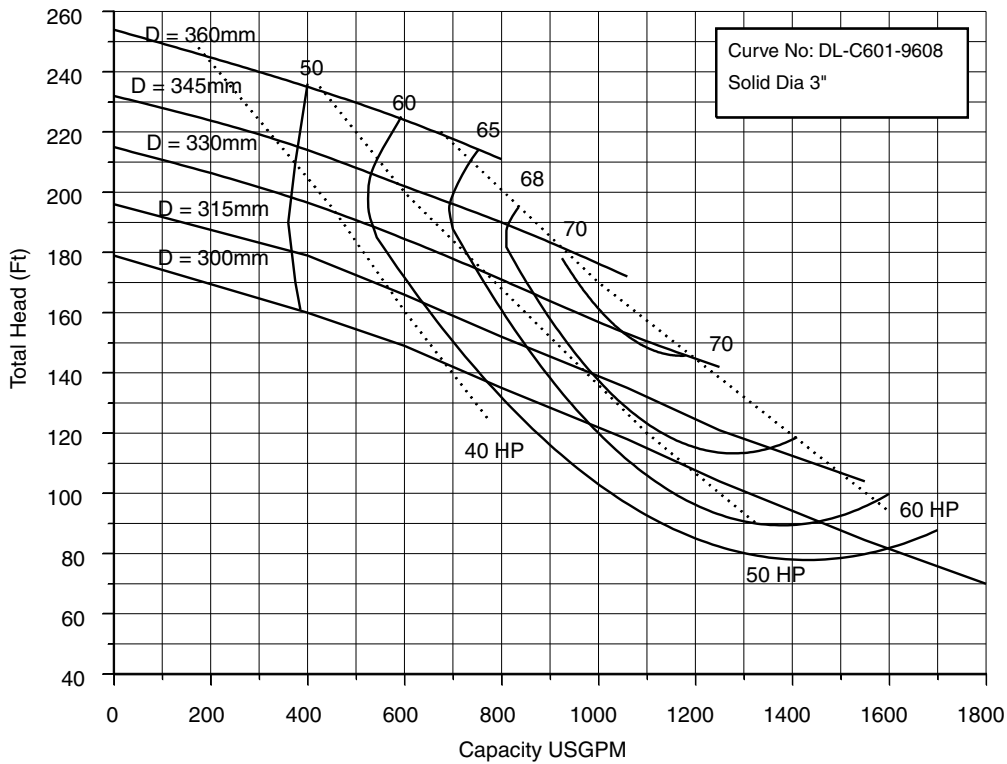

200x150DDL611 (15HP) Synchronous Speed: 1800 RPM 8 inch Suction 6 inch Discharge

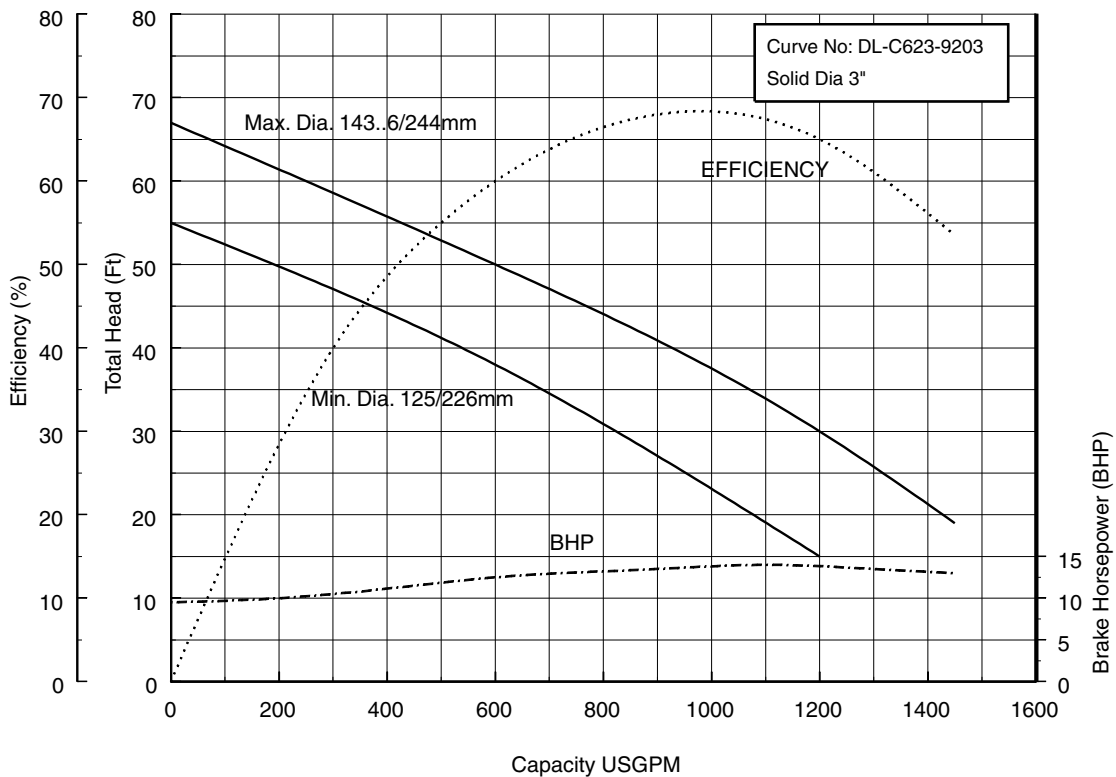

Performance Curves

Project: _____ GPM: _____ TDH: _____ EFF: _____ HP: _____ Chk'd: _____ Date: _____

200x150DDL F615 (20HP) Synchronous Speed: 1800 RPM 8 inch Suction 6 inch Discharge

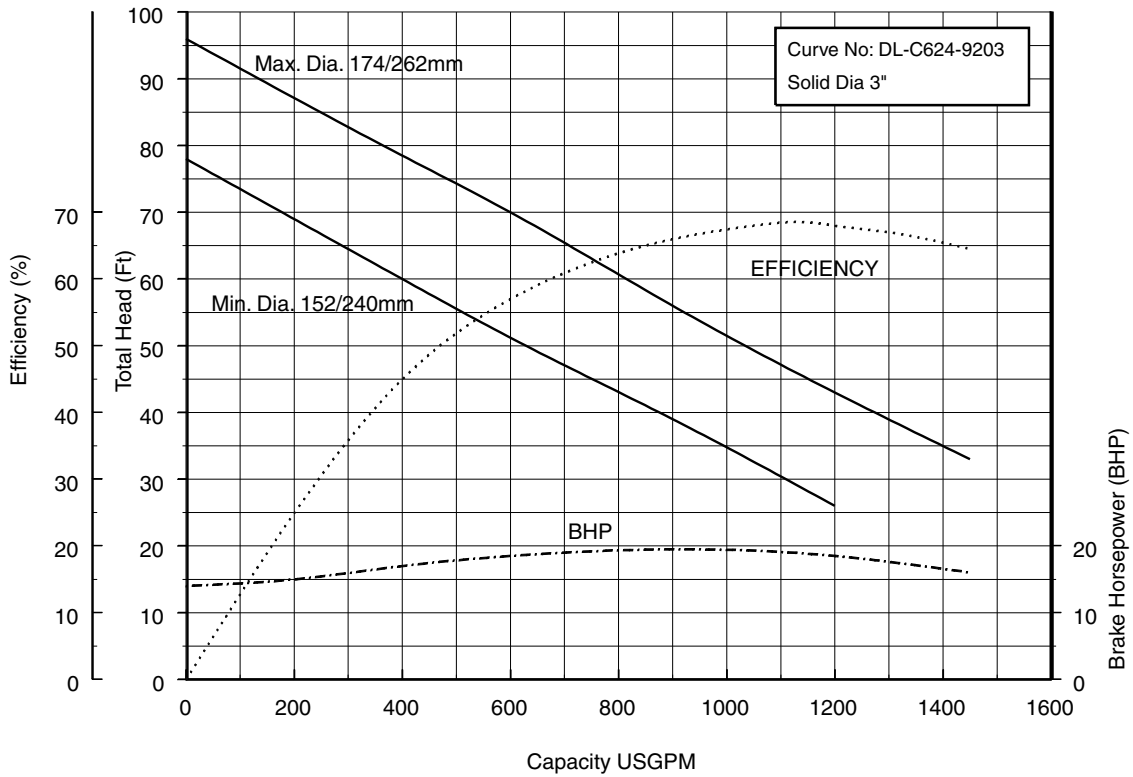

200x150DDL F618 (25HP) Synchronous Speed: 1800 RPM 8 inch Suction 6 inch Discharge

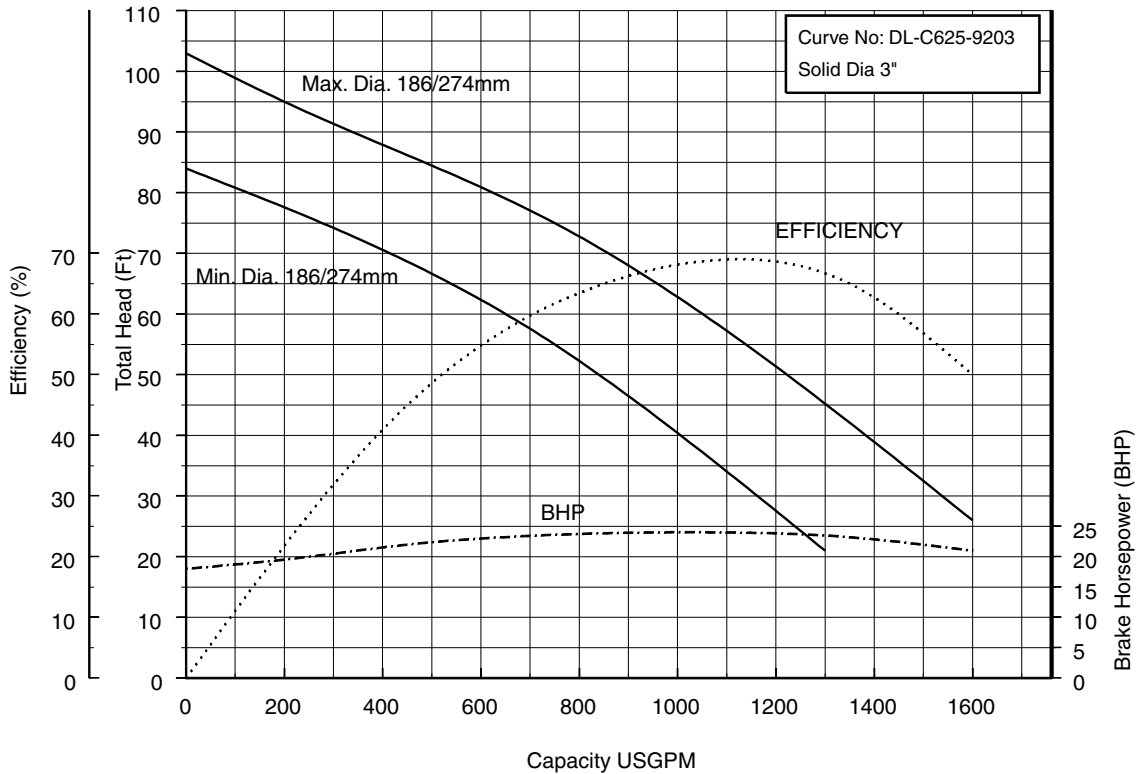

Performance Curves

Project: _____ GPM: _____ TDH: _____ EFF: _____ HP: _____ Chk'd: _____ Date: _____

200x150DDL622 (30HP) Synchronous Speed: 1800 RPM 8 inch Suction 6 inch Discharge

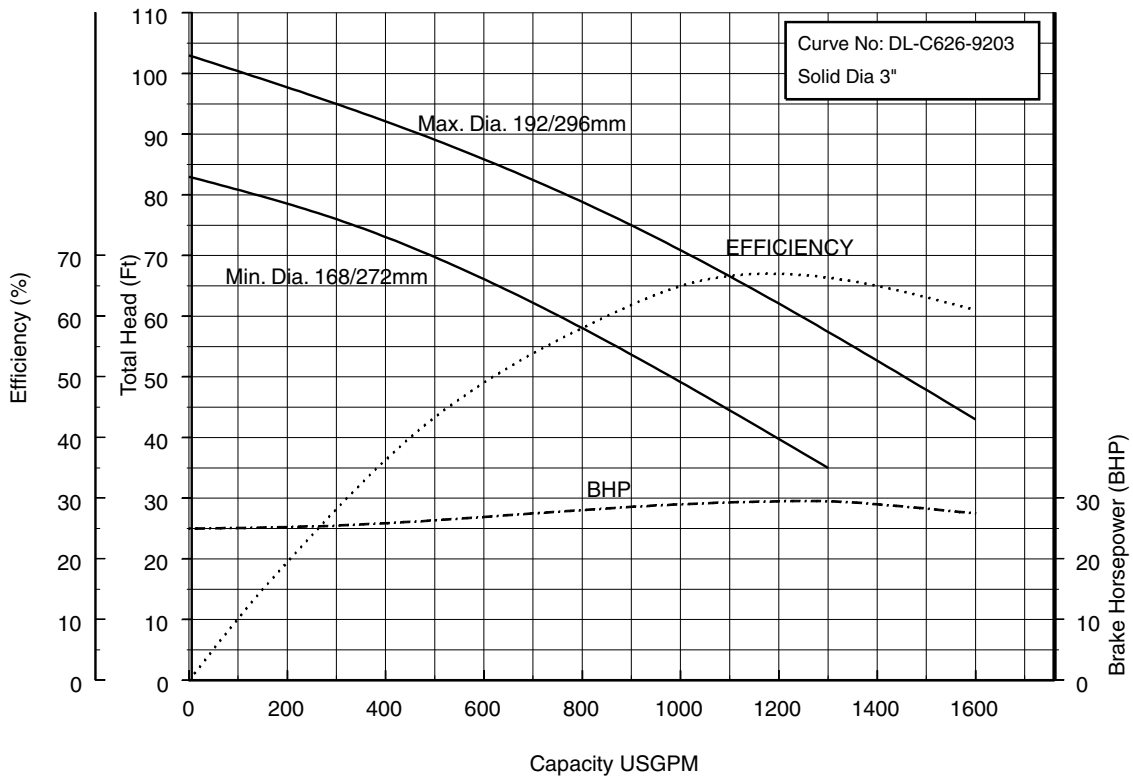

200x150DDL630 (40HP) Synchronous Speed: 1800 RPM 8 inch Suction 6 inch Discharge

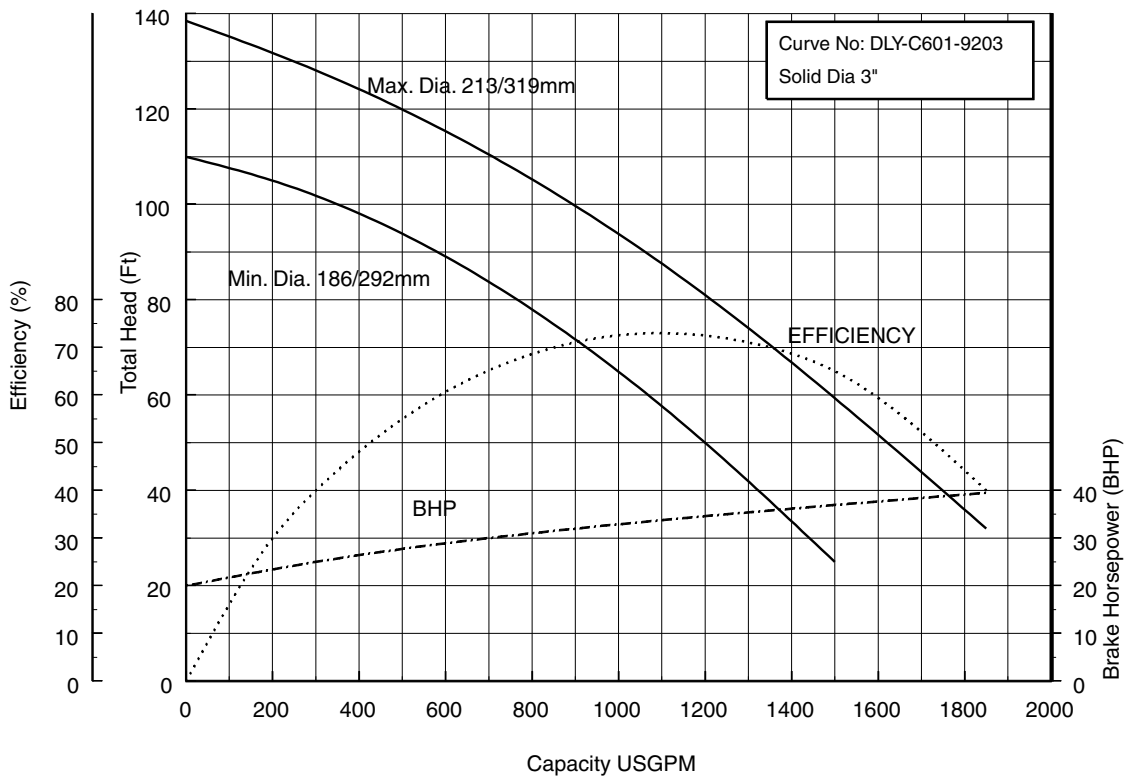

Performance Curves

Project: _____ GPM: _____ TDH: _____ EFF: _____ HP: _____ Chk'd: _____ Date: _____

200x150DDL637 (50HP) Synchronous Speed: 1800 RPM 8 inch Suction 6 inch Discharge

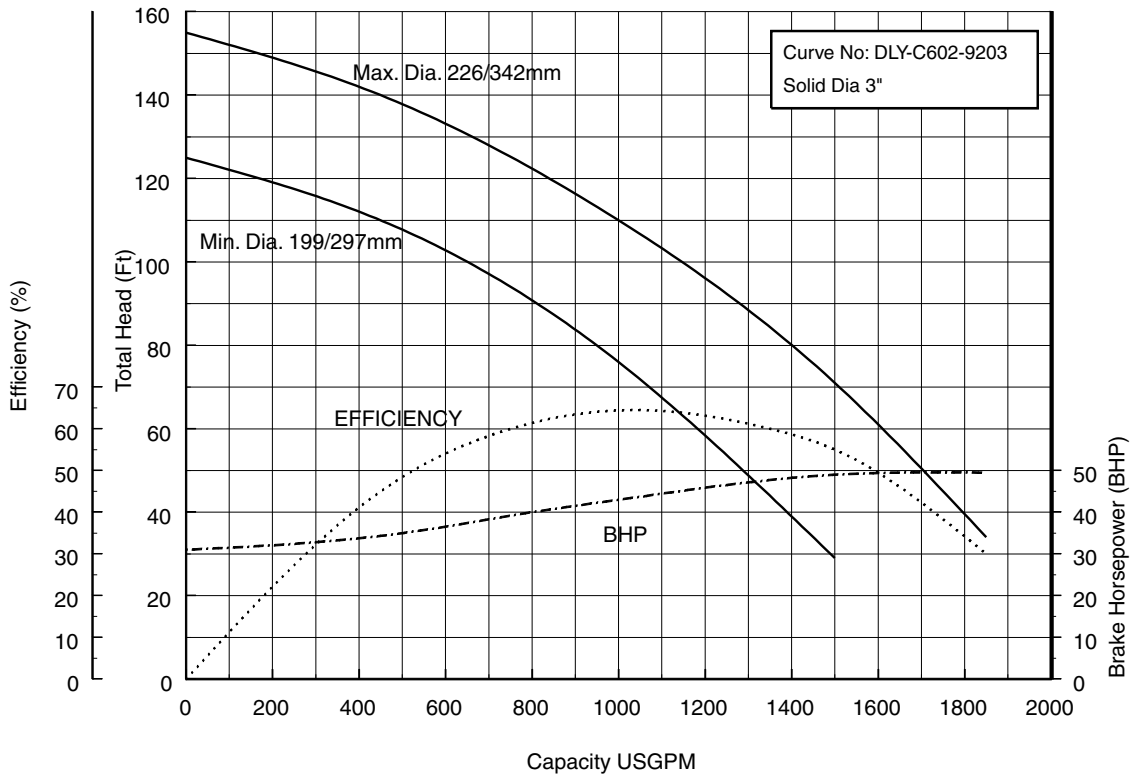

200x150DDL645 (60HP) Synchronous Speed: 1800 RPM 8 inch Suction 6 inch Discharge

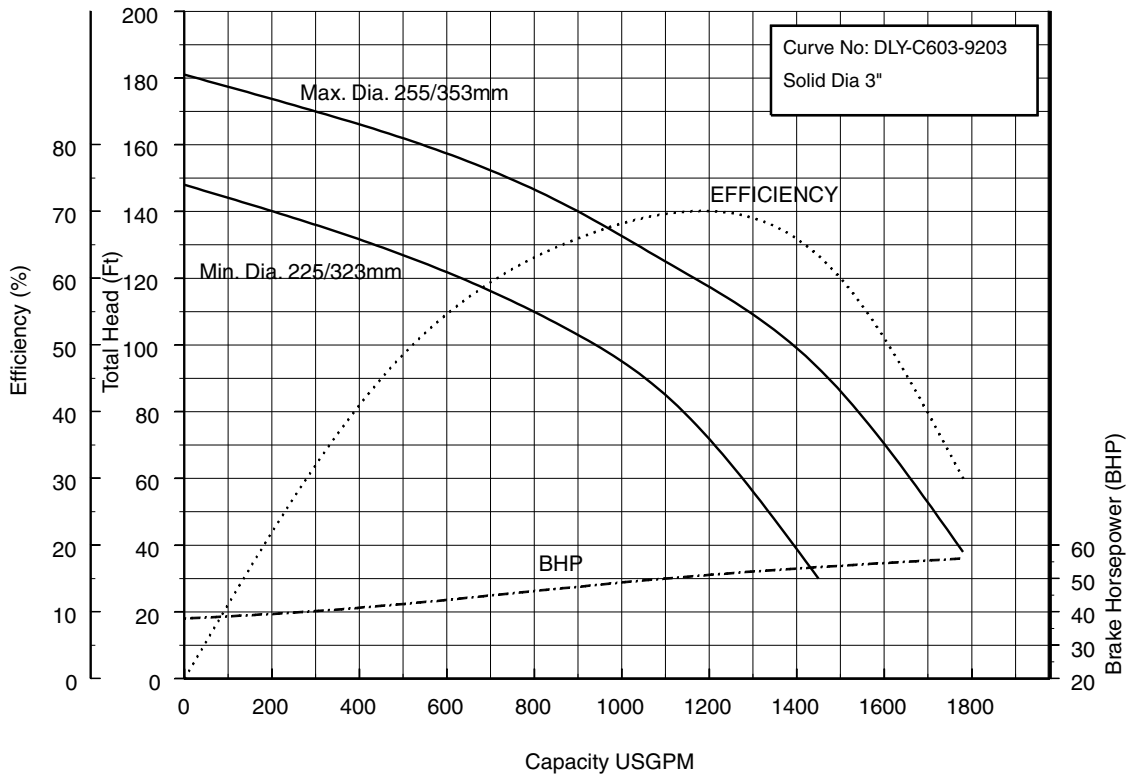

Performance Curves

Project: _____ GPM: _____ TDH: _____ EFF: _____ HP: _____ Chk'd: _____ Date: _____

200x200DDL630 (40HP) Synchronous Speed: 1800 RPM 8 inch Suction 8 inch Discharge

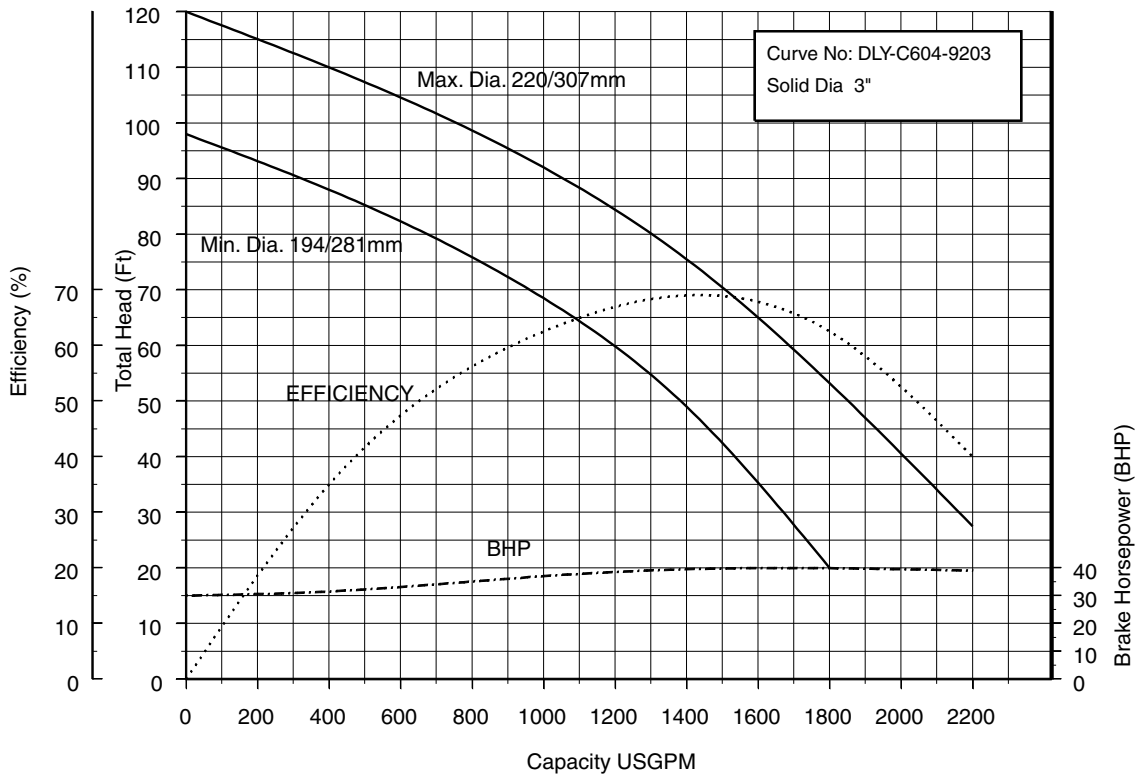

200x200DDL637 (50HP) Synchronous Speed: 1800 RPM 8 inch Suction 8 inch Discharge

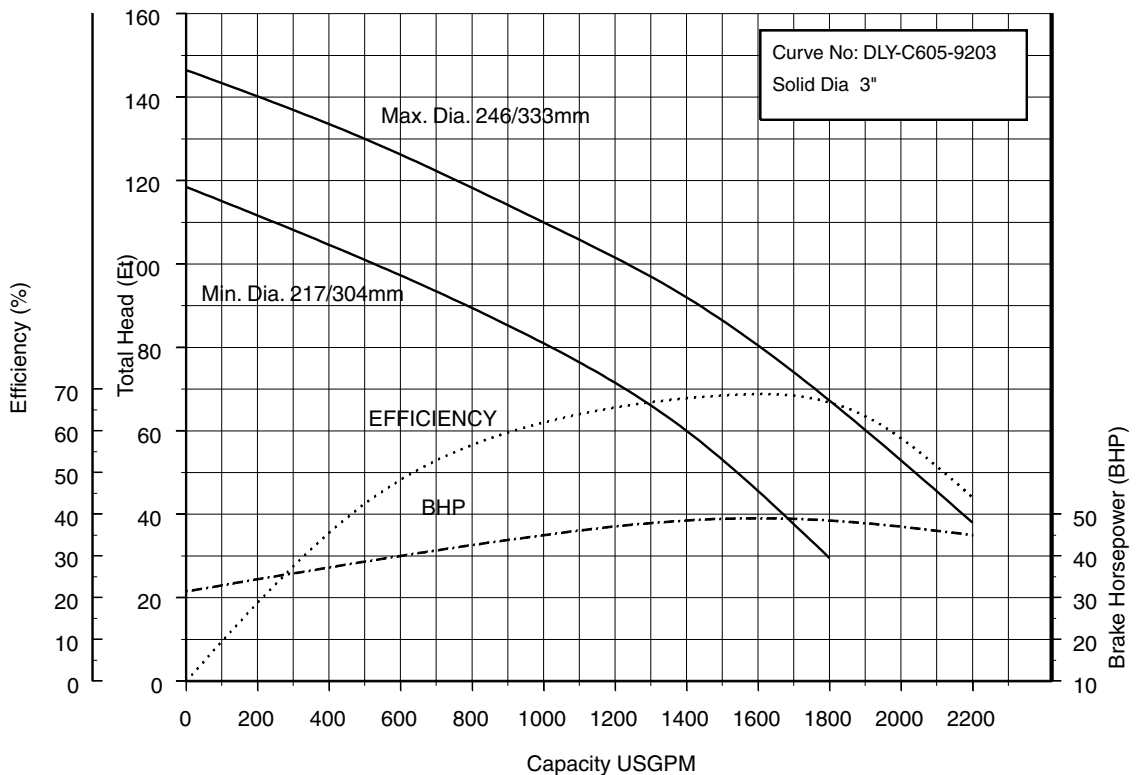

Performance Curves

Project: _____ GPM: _____ TDH: _____ EFF: _____ HP: _____ Chk'd: _____ Date: _____

200x200DDL645 (60HP) Synchronous Speed: 1800 RPM 8 inch Suction 8 inch Discharge

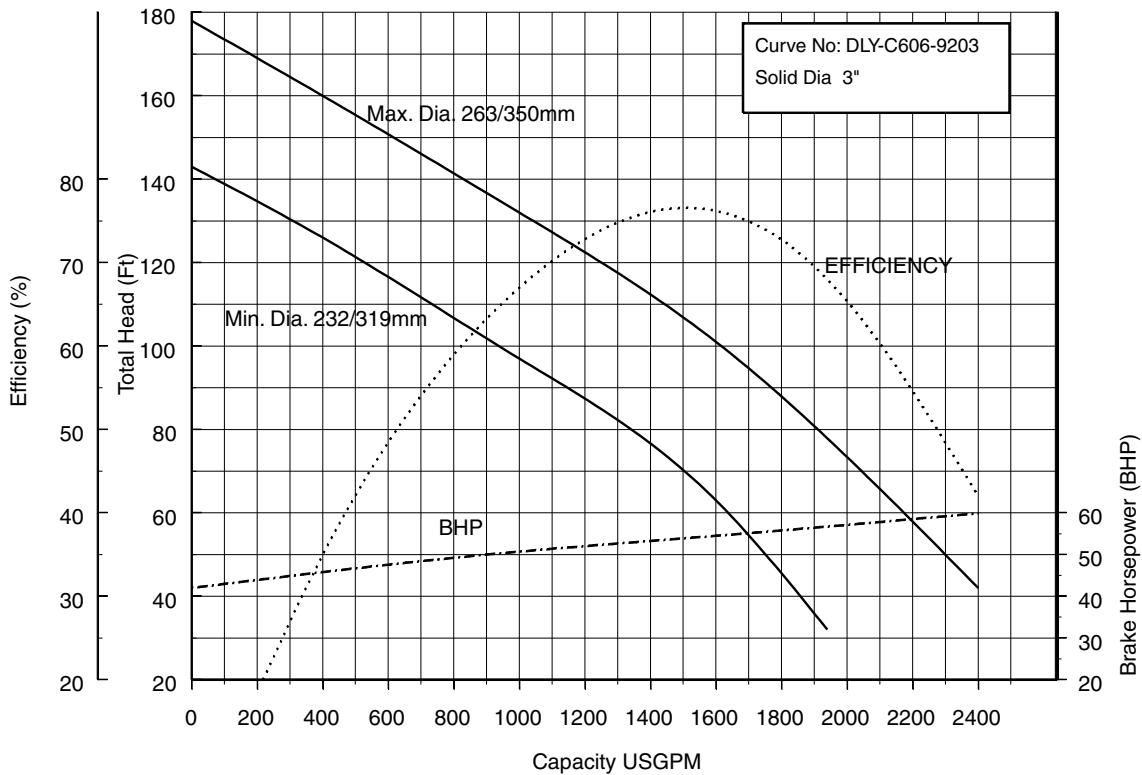

250x250DDL630 (40HP) Synchronous Speed: 1800 RPM 10 inch Suction 10 inch Discharge

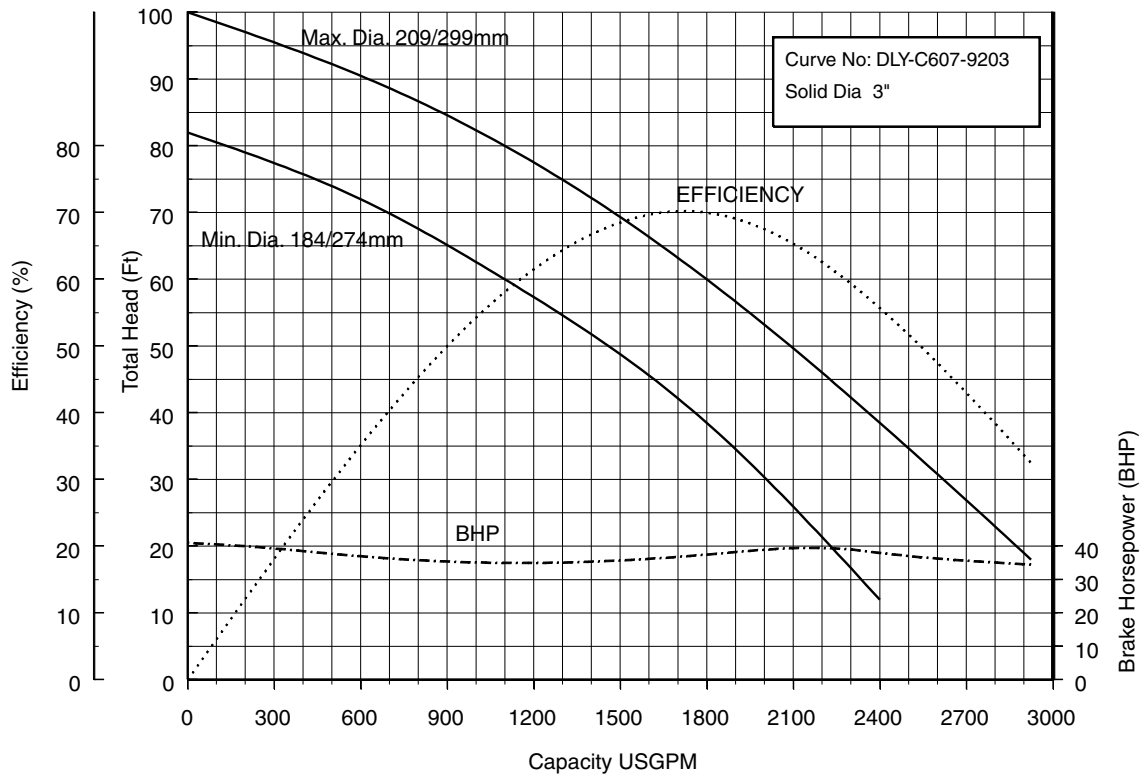

Performance Curves

Project: _____ GPM: _____ TDH: _____ EFF: _____ HP: _____ Chk'd: _____ Date: _____

250x250DDL637 (50HP) Synchronous Speed: 1800 RPM 10 inch Suction 10 inch Discharge

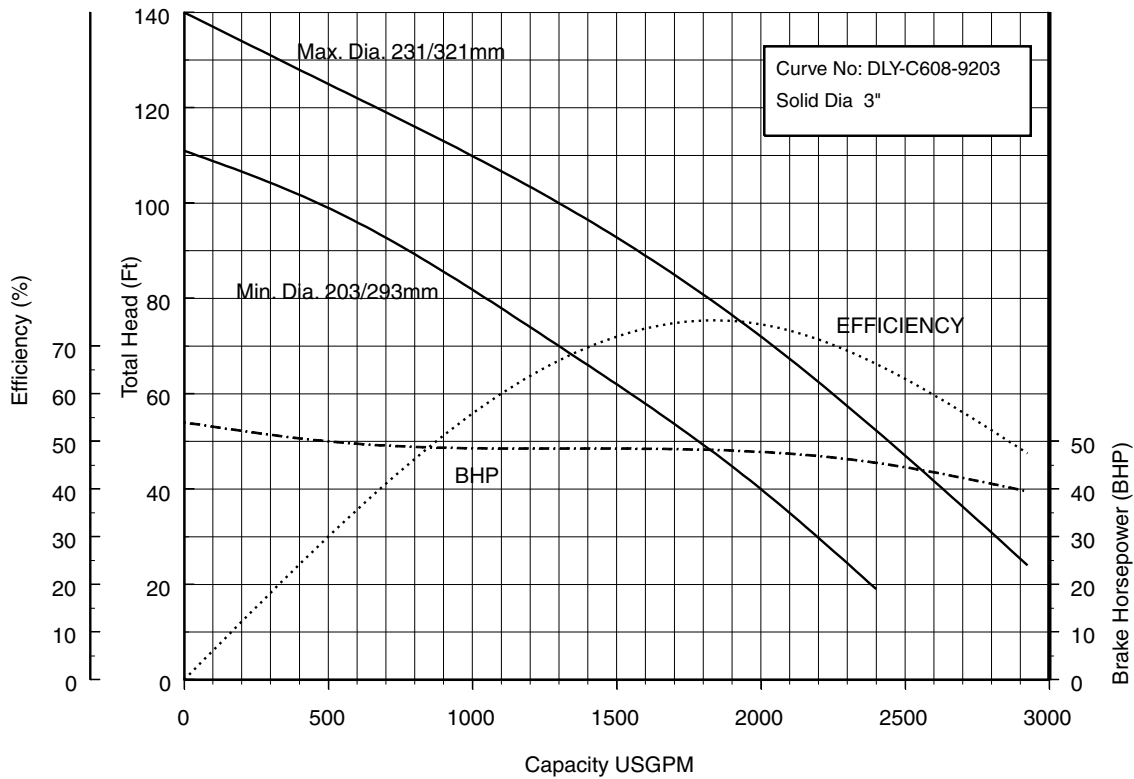

250x250DDL645 (60HP) Synchronous Speed: 1800 RPM 10 inch Suction 10 inch Discharge

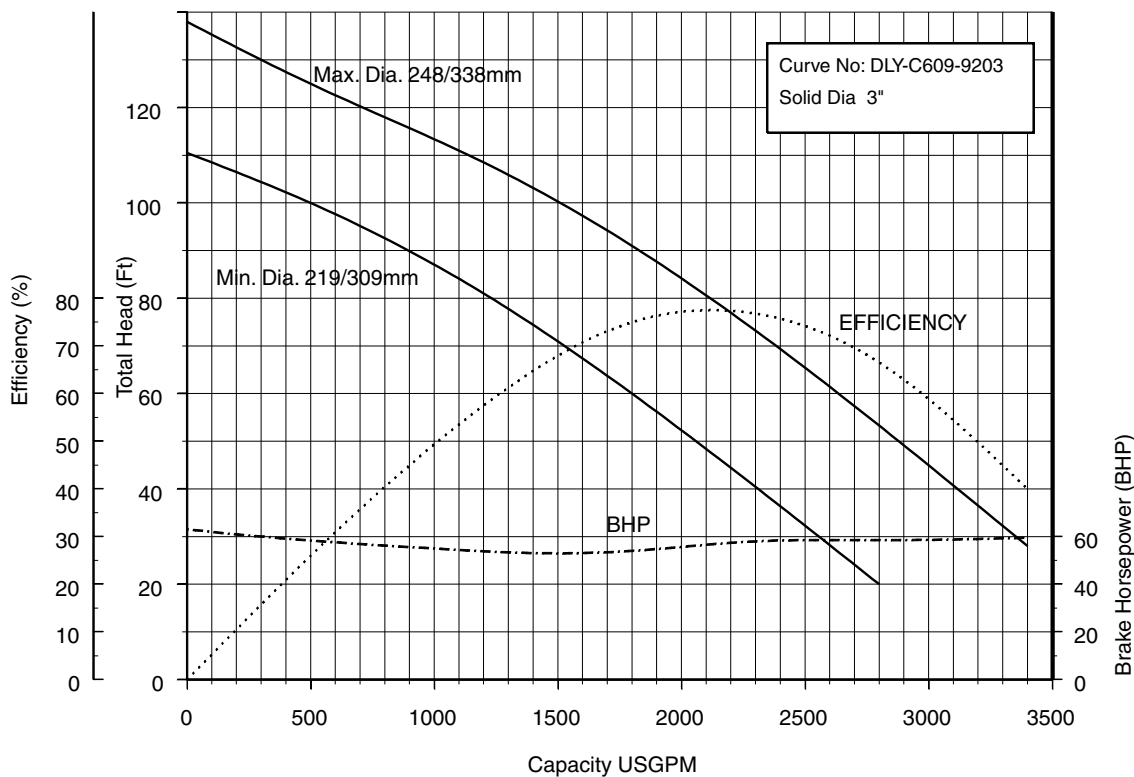

Performance Curves

Project: _____ GPM: _____ TDH: _____ EFF: _____ HP: _____ Chk'd: _____ Date: _____

300x300DDL630 (40HP) Synchronous Speed: 1800 RPM 12 inch Suction 12 inch Discharge

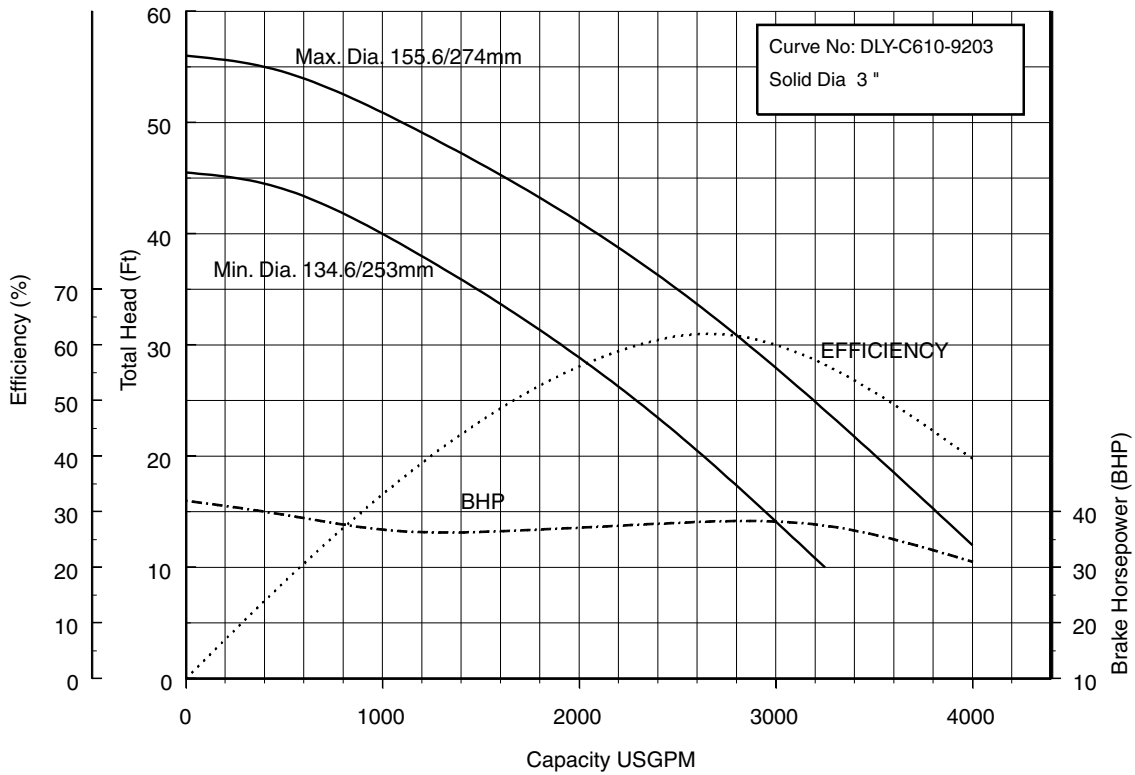

300x300DDL637 (50HP) Synchronous Speed: 1800 RPM 12 inch Suction 12 inch Discharge

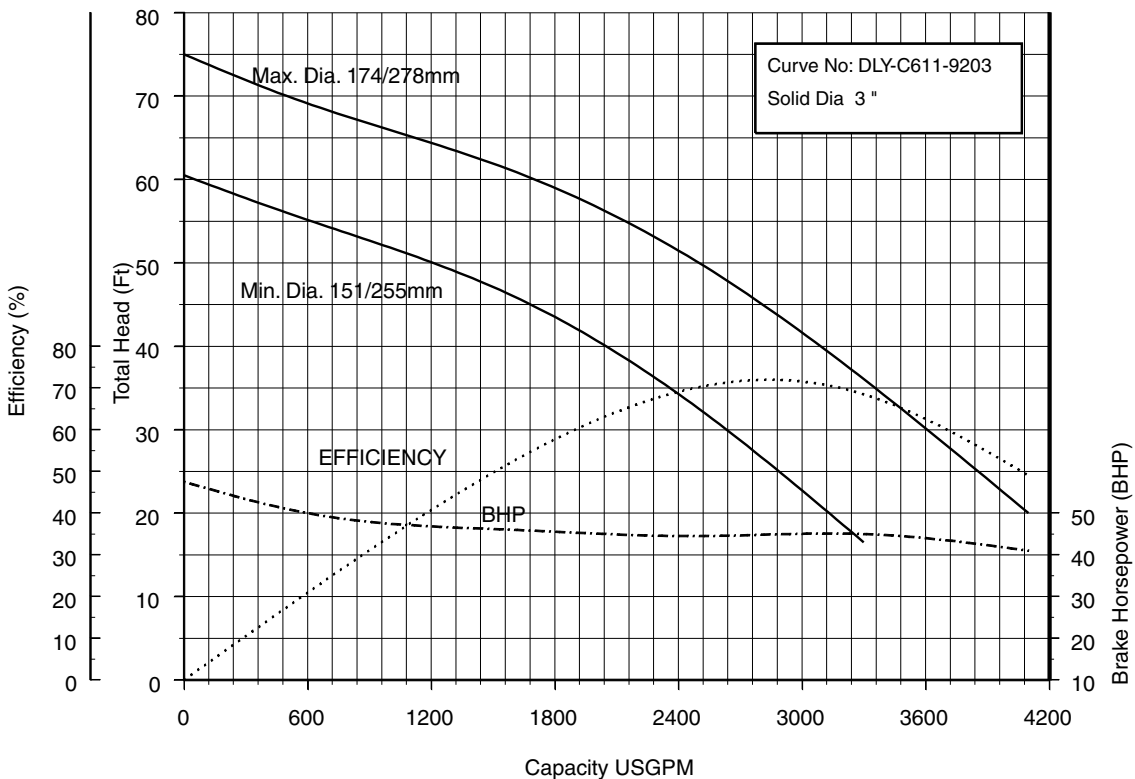

Performance Curves

Project: _____ GPM: _____ TDH: _____ EFF: _____ HP: _____ Chk'd: _____ Date: _____

300x300DDL645 (60HP) Synchronous Speed: 1800 RPM 12 inch Suction 12 inch Discharge

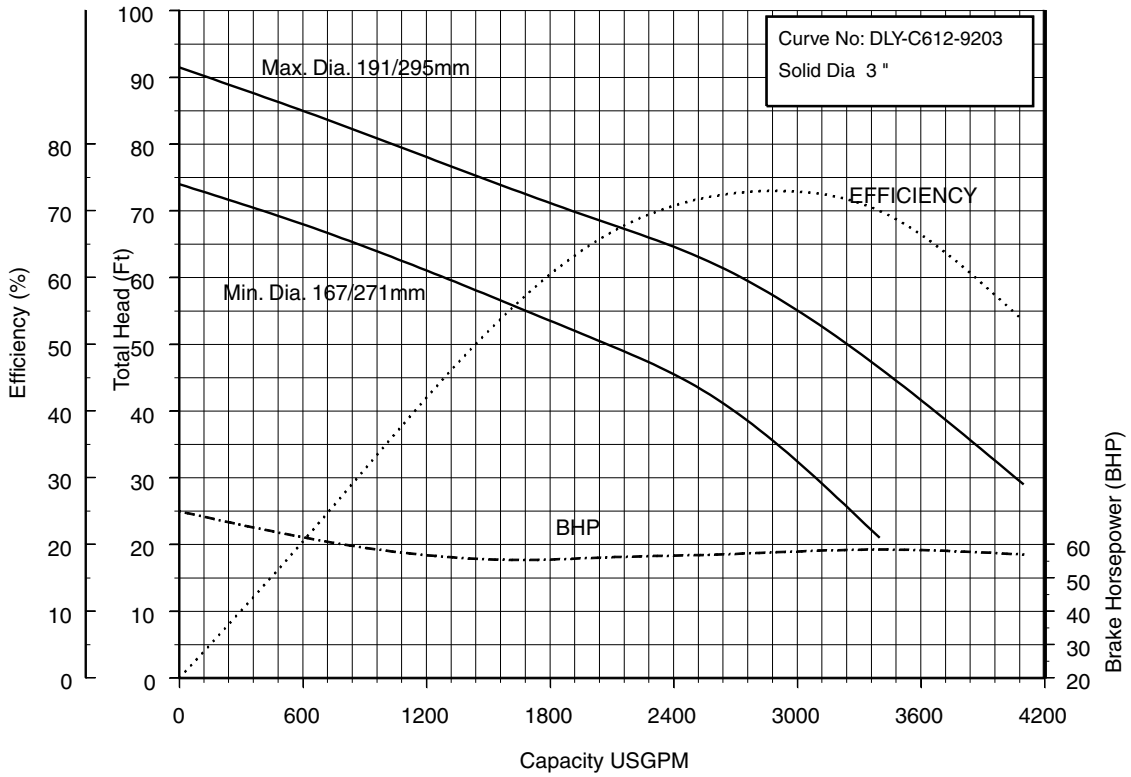

Dimensions

Project: _____ Model: _____ Chk'd: _____ Date: _____

Model DDLFU (Dry Pit Type)
100 x 80DDLUFU, 15 to 30HP

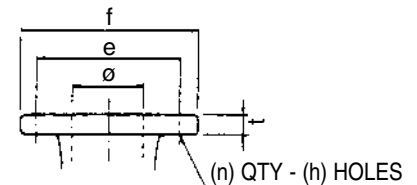
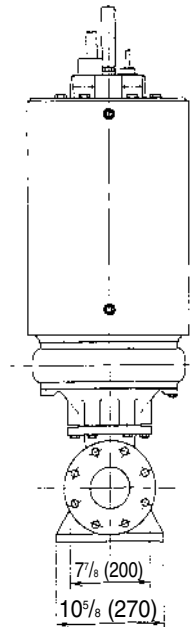
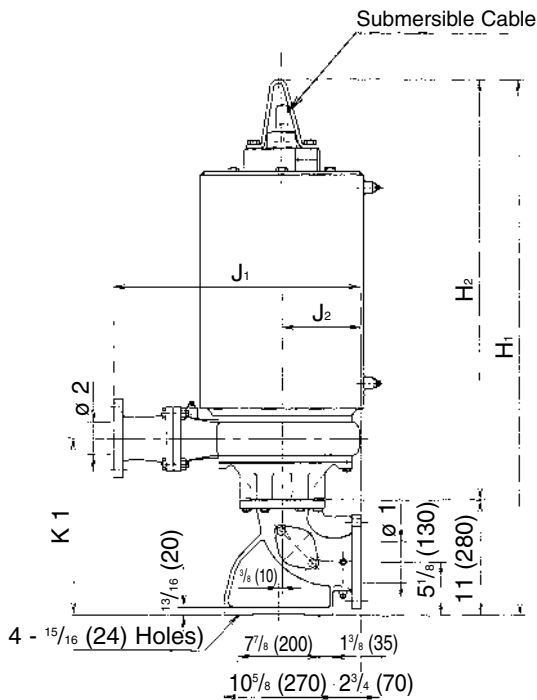
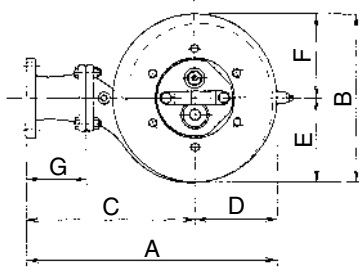

Flange (ANSI 125 PSI F.F)

inch					
ø	e	f	t	n	h
3	6	7 1/2	3/4	4	3/4
4	7 1/2	9	15/16	8	3/4

mm					
ø	e	f	t	n	h
80	152	191	19	4	19
100	191	229	24	8	19

Note: Discharge can be rotated in 45° increments.

Dimensions: inch

PHASE	SIZE		MODEL	OUTPUT		PUMP & MOTOR											WEIGHT Lb	
	ø1	ø2		kW	HP	A	B	C	D	E	F	G	H ₁	H ₂	J ₁	J ₂		K ₁
THREE	4	3	100x80DDLUFU611	11	15	24 1/8	15 3/16	16 9/16	7 5/8	8 1/16	7 1/16	5 7/8	49	38	24 3/16	7 11/16	16 7/8	767
			100x80DDLUFU615	15	20	24 1/8	15 3/16	16 9/16	7 5/8	8 1/16	7 1/16	5 7/8	51 3/4	40 3/4	24 3/16	7 11/16	16 7/8	895
			100x80DDLUFU618	18.5	25	25 5/16	16 5/16	17 5/16	8	8 3/8	8	5 7/8	53 3/8	42 5/16	25	7 11/16	16 7/8	947
			100x80DDLUFU622	22	30	25 5/16	16 5/16	17 5/16	8	8 3/8	8	5 7/8	53 3/8	42 5/16	25	7 11/16	16 7/8	996

Dimensions: mm

PHASE	SIZE		MODEL	OUTPUT		PUMP & MOTOR											WEIGHT kg	
	ø1	ø2		kW	HP	A	B	C	D	E	F	G	H ₁	H ₂	J ₁	J ₂		K ₁
THREE	100	80	100x80DDLUFU611	11	15	613	385	420	193	205	180	150	1245	965	615	195	428	348
			100x80DDLUFU615	15	20	613	385	420	193	205	180	150	1315	1035	615	195	428	406
			100x80DDLUFU618	18.5	25	643	415	440	203	212	203	150	1355	1075	635	195	428	430
			100x80DDLUFU622	22	30	643	415	440	203	212	203	150	1355	1075	635	195	428	452



Dimensions

Project: _____ Model: _____ Chk'd: _____ Date: _____

Model DDLFU (Dry Pit Type)
150 x 100DDLUFU, 15 to 30HP

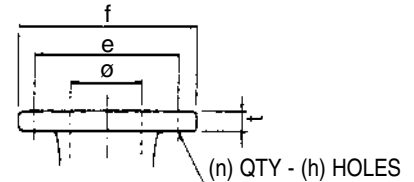
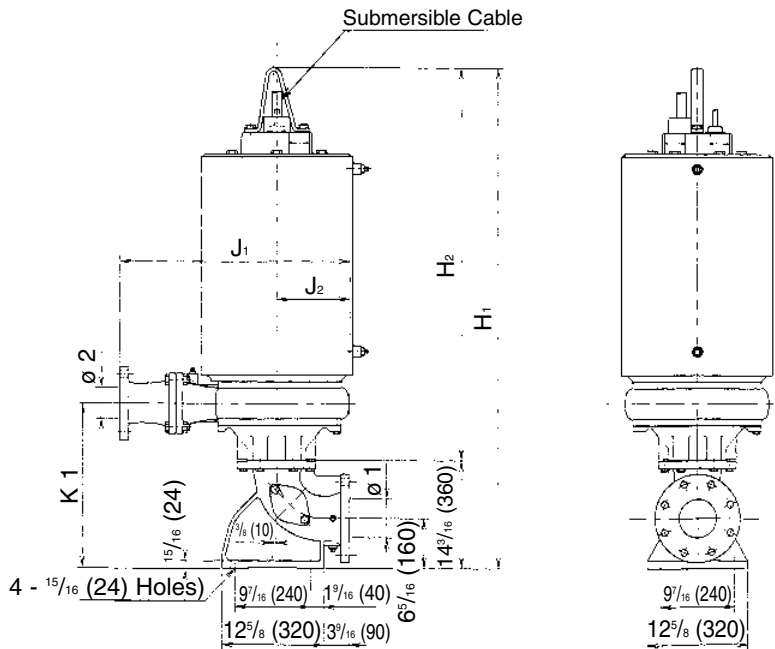
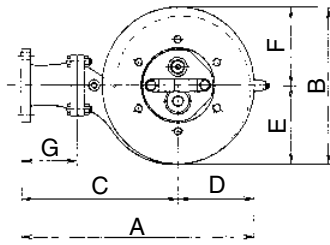

Flange (ANSI 125 PSI F.F)

inch					
ø	e	f	t	n	h
4	7 1/2	9	1 5/16	8	3/4
6	9 1/2	11	1	8	7/8

mm					
ø	e	f	t	n	h
100	191	229	24	8	19
150	241	279	25	8	22

Note: Discharge can be rotated in 45° increments.

Dimensions: inch

PHASE	SIZE		MODEL	OUTPUT		PUMP & MOTOR											WEIGHT Lb	
	ø1	ø2		kW	HP	A	B	C	D	E	F	G	H ₁	H ₂	J ₁	J ₂		K ₁
THREE	6	4	150x100DDLUFU611	11	15	24 3/4	15 11/16	16 7/8	7 7/8	8 9/16	7 1/16	5 7/8	52 5/8	38 7/16	26 5/16	9 7/16	19 3/16	813
			150x100DDLUFU615	15	20	26	16 15/16	17 11/16	8 1/4	8 15/16	8	5 7/8	54 13/16	40 5/8	27 3/16	9 7/16	19 3/4	921
			150x100DDLUFU618	18.5	25	27 3/16	17 5/16	18 1/2	8 11/16	9 5/16	8	5 7/8	56 11/16	40 1/2	27 15/16	9 7/16	20	1009
			150x100DDLUFU622	22	30	27 3/16	17 5/16	18 1/2	8 11/16	9 5/16	8	5 7/8	56 11/16	40 1/2	27 15/16	9 7/16	20	1058

Dimensions: mm

PHASE	SIZE		MODEL	OUTPUT		PUMP & MOTOR											WEIGHT kg	
	ø1	ø2		kW	HP	A	B	C	D	E	F	G	H ₁	H ₂	J ₁	J ₂		K ₁
THREE	150	100	150x100DDLUFU611	11	15	628	398	428	200	218	180	150	1337	977	668	240	503	369
			150x100DDLUFU615	15	20	660	430	450	210	227	203	150	1392	1032	690	240	501	418
			150x100DDLUFU618	18.5	25	690	439	470	220	236	203	150	1440	1080	710	240	508	458
			150x100DDLUFU622	22	30	690	439	470	220	236	203	150	1440	1080	710	240	508	480



Dimensions

Project: _____ Model: _____ Chk'd: _____ Date: _____

Model DDLFU (Dry Pit Type)
150 x 100DDLUFU, 40 to 60HP

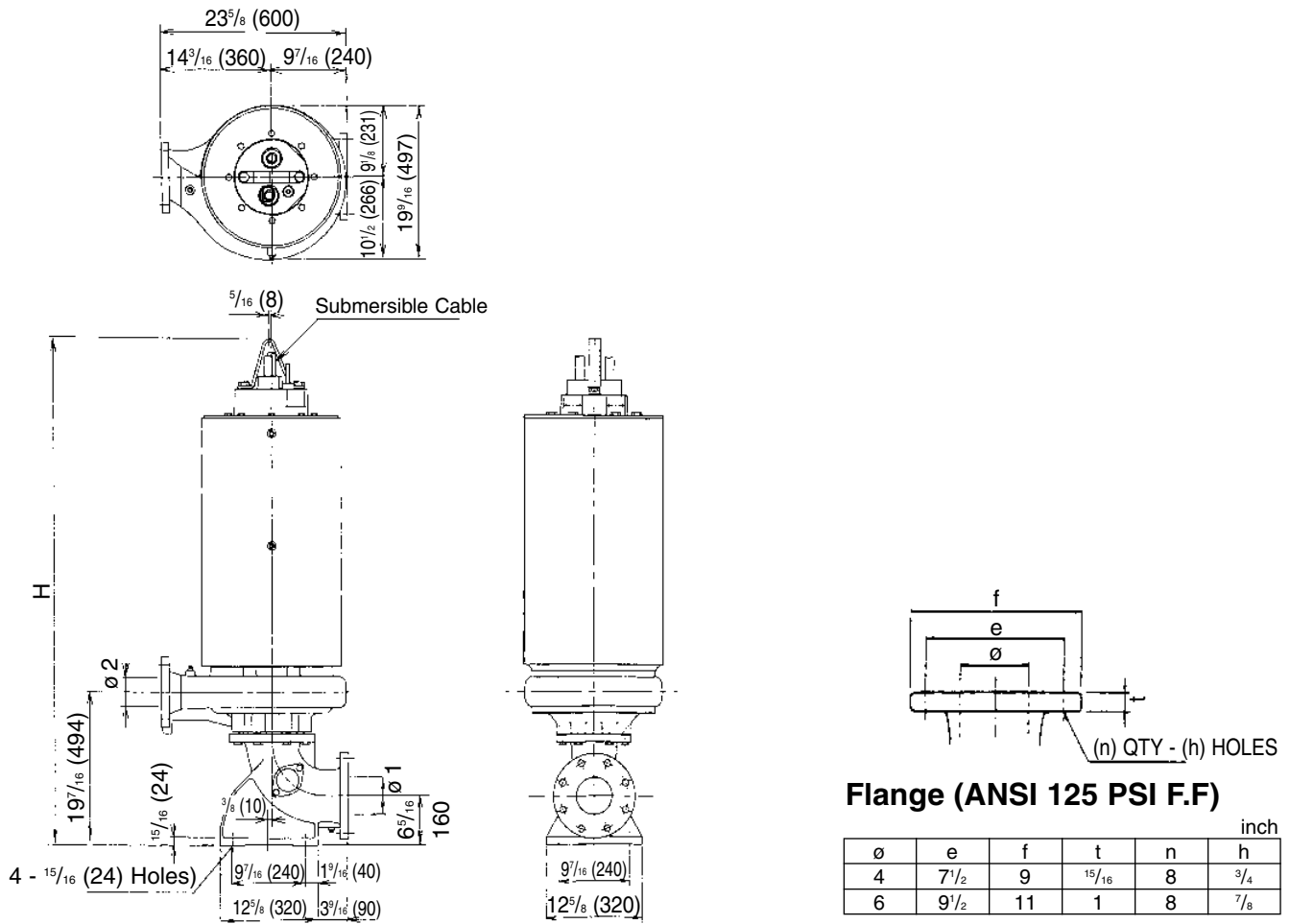

Note: Discharge can be rotated in 45° increments.

Dimensions: inch

PHASE	SIZE		MODEL	OUTPUT		PUMP & MOTOR	WEIGHT Lb
	ø1	ø2		kW	HP	H	
THREE	6	4	150x100DDLUFU630	30	40	62 1/16	1164
			150x100DDLUFU637	37	50	65 5/8	1314
			150x100DDLUFU645	45	60	65 5/8	1373

Dimensions: mm

PHASE	SIZE		MODEL	OUTPUT		PUMP & MOTOR	WEIGHT kg
	ø1	ø2		kW	HP	H	
THREE	150	100	150x100DDLUFU630	30	40	1577	528
			150x100DDLUFU637	37	50	1677	596
			150x100DDLUFU645	45	60	1677	623

Flange (ANSI 125 PSI F.F)

ø	e	f	t	n	h
4	7 1/2	9	15/16	8	3/4
6	9 1/2	11	1	8	7/8

inch

ø	e	f	t	n	h
100	191	229	24	8	19
150	241	279	25	8	22

mm



Dimensions

Project: _____ Model: _____ Chk'd: _____ Date: _____

Model DDLFU (Dry Pit Type)
200 x 150DDLUFU, 15 to 30HP

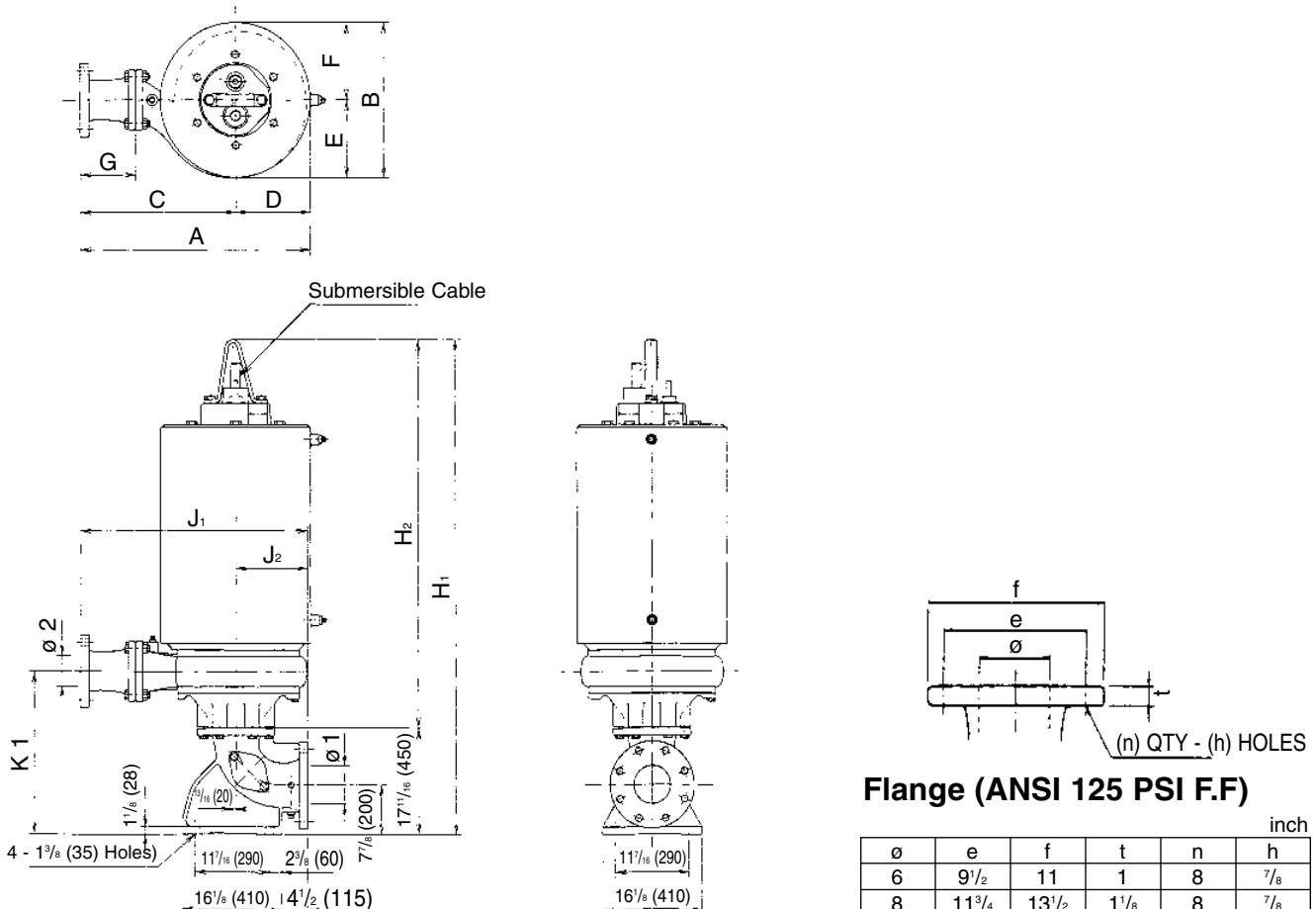

Flange (ANSI 125 PSI F.F)

inch	ø	e	f	t	n	h
	6	9 1/2	11	1	8	7/8
	8	11 3/4	13 1/2	1 1/8	8	7/8

mm	ø	e	f	t	n	h
	150	241	279	25	8	22
	200	299	343	29	8	22

Note: Discharge can be rotated in 30° increments.

Dimensions: inch

PHASE	SIZE		MODEL	OUTPUT		PUMP & MOTOR											WEIGHT Lb	
	ø1	ø2		KW	HP	A	B	C	D	E	F	G	H ₁	H ₂	J ₁	J ₂		K ₁
THREE	8	6	200x150DDLUFU611	11	15	26 1/4	16 15/16	17 11/16	8 9/16	9 7/16	7 9/16	5 7/8	57 1/2	39 13/16	29 1/2	11 13/16	24 7/16	864
			200x150DDLUFU615	15	20	27 1/2	17 13/16	18 1/2	9	9 13/16	8	5 7/8	60 7/8	43 3/16	30 5/16	11 13/16	25 1/2	970
			200x150DDLUFU618	18.5	25	27 1/2	17 13/16	18 1/2	9	9 13/16	8	5 7/8	62 1/2	44 3/4	30 5/16	11 13/16	25 1/2	1009
			200x150DDLUFU622	22	30	28 3/4	18 7/8	19 5/16	9 1/2	10 3/8	8 1/2	5 7/8	62 3/8	44 5/8	31 1/8	11 13/16	25 1/2	1109

Dimensions: mm

PHASE	SIZE		MODEL	OUTPUT		PUMP & MOTOR											WEIGHT kg	
	ø1	ø2		KW	HP	A	B	C	D	E	F	G	H ₁	H ₂	J ₁	J ₂		K ₁
THREE	200	150	200x150DDLUFU611	11	15	667	431	450	217	239	192	150	1461	1011	750	300	620	392
			200x150DDLUFU615	15	20	698	453	470	228	250	203	150	1547	1097	770	300	648	440
			200x150DDLUFU618	18.5	25	698	453	470	228	250	203	150	1587	1137	770	300	648	458
			200x150DDLUFU622	22	30	731	479	490	241	263	216	150	1584	1134	790	300	648	503



Dimensions

Project: _____ Model: _____ Chk'd: _____ Date: _____

Model DDLUFU (Dry Pit Type)
200 × 150DDLUFU, 40 to 60HP
200 × 200DDLUFU, 40 to 60HP

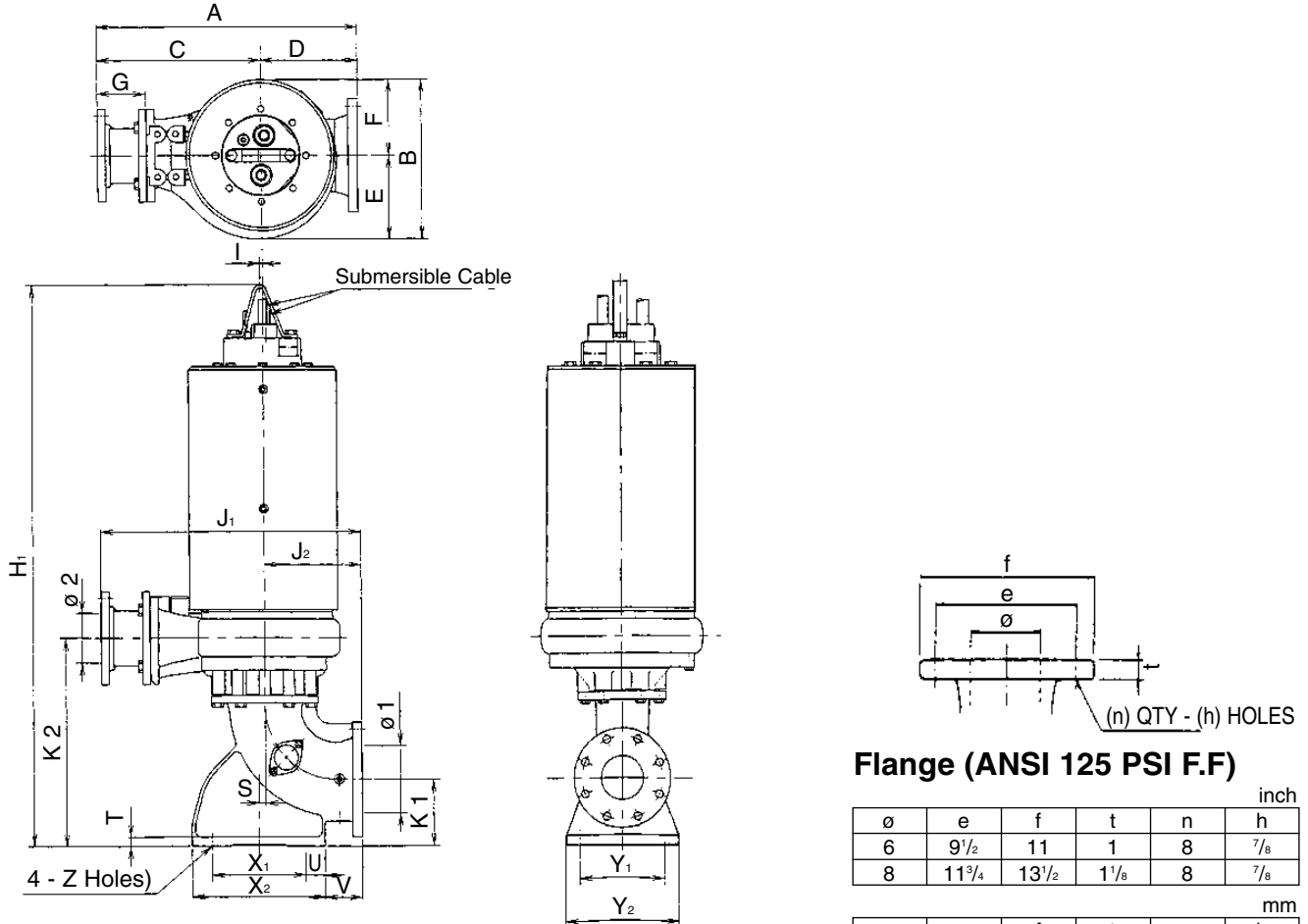

Note: Discharge can be rotated in 30° increments.

Flange (ANSI 125 PSI F.F)

inch					
ø	e	f	t	n	h
6	9 1/2	11	1	8	7/8
8	11 3/4	13 1/2	1 1/8	8	7/8

mm					
ø	e	f	t	n	h
150	241	279	25	8	22
200	299	343	29	8	22

Dimensions: inch

PHASE	SIZE		MODEL	OUTPUT		PUMP & MOTOR																	WEIGHT Lb					
	ø1	ø2		kW	HP	A	B	C	D	E	F	G	H ₁	I	J ₁	J ₂	K ₁	K ₂	S	T	U	V		X ₁	X ₂	Y ₁	Y ₂	Z
THREE	8	6	200x150DDLUFU630	30	40	29	18 9/16	19 1/4	9 1/16	10	8 9/16	5 7/8	64 11/16	5 1/16	31 1/16	11 13/16	7 7/8	24 5/8	1 3/16	1 1/8	2 3/8	4 1/2	11 7/16	16 1/8	11 7/16	16 1/8	1 3/8	1642
			200x150DDLUFU637	37	50	29	18 9/16	19 1/4	9 1/16	10	8 9/16	5 7/8	66 7/8	5 1/16	31 1/16	11 13/16	7 7/8	24 5/8	1 3/16	1 1/8	2 3/8	4 1/2	11 7/16	16 1/8	11 7/16	16 1/8	1 3/8	1713
			200x150DDLUFU645	45	60	29	18 9/16	19 1/4	9 1/16	10	8 9/16	5 7/8	66 7/8	5 1/16	31 1/16	11 13/16	7 7/8	24 5/8	1 3/16	1 1/8	2 3/8	4 1/2	11 7/16	16 1/8	11 7/16	16 1/8	1 3/8	1772
	8	8	200x200DDLUFU630	30	40	34 3/16	20 9/16	23 3/8	10 3/8	11 1/16	9 3/8	9 5/8	64 11/16	5 1/16	35 11/16	11 13/16	7 7/8	24 1/2	1 3/16	1 1/8	2 3/8	4 1/2	11 7/16	16 1/8	11 7/16	16 1/8	1 3/8	1695
			200x200DDLUFU637	37	50	34 3/16	20 9/16	23 3/8	10 3/8	11 1/16	9 3/8	9 5/8	66 7/8	5 1/16	35 11/16	11 13/16	7 7/8	24 1/2	1 3/16	1 1/8	2 3/8	4 1/2	11 7/16	16 1/8	11 7/16	16 1/8	1 3/8	1765
			200x200DDLUFU645	45	60	34 3/16	20 9/16	23 3/8	10 3/8	11 1/16	9 3/8	9 5/8	66 7/8	5 1/16	35 11/16	11 13/16	7 7/8	24 1/2	1 3/16	1 1/8	2 3/8	4 1/2	11 7/16	16 1/8	11 7/16	16 1/8	1 3/8	1825

Dimensions: mm

PHASE	SIZE		MODEL	OUTPUT		PUMP & MOTOR																	WEIGHT kg					
	ø1	ø2		kW	HP	A	B	C	D	E	F	G	H ₁	I	J ₁	J ₂	K ₁	K ₂	S	T	U	V		X ₁	X ₂	Y ₁	Y ₂	Z
THREE	200	150	200x150DDLUFU630	30	40	737	471	501	236	254	218	150	1593	8	801	300	200	625	20	28	60	115	290	410	290	410	35	745
			200x150DDLUFU637	37	50	737	471	501	236	254	218	150	1698	8	801	300	200	625	20	28	60	115	290	410	290	410	35	777
			200x150DDLUFU645	45	60	737	471	501	236	254	218	150	1698	8	801	300	200	625	20	28	60	115	290	410	290	410	35	804
	200	200	200x200DDLUFU630	30	40	868	522	606	263	284	238	245	1593	8	906	300	200	623	20	28	60	115	290	410	290	410	35	769
			200x200DDLUFU637	37	50	868	522	606	263	284	238	245	1698	8	906	300	200	623	20	28	60	115	290	410	290	410	35	801
			200x200DDLUFU645	45	60	868	522	606	263	284	238	245	1698	8	906	300	200	623	20	28	60	115	290	410	290	410	35	828



Dimensions

Project: _____ Model: _____ Chk'd: _____ Date: _____

Model DDLFU (Dry Pit Type)
250 × 250DDLUFU, 40 to 60HP
300 × 300DDLUFU, 40 to 60HP

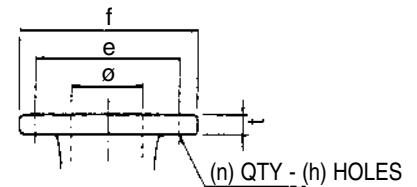
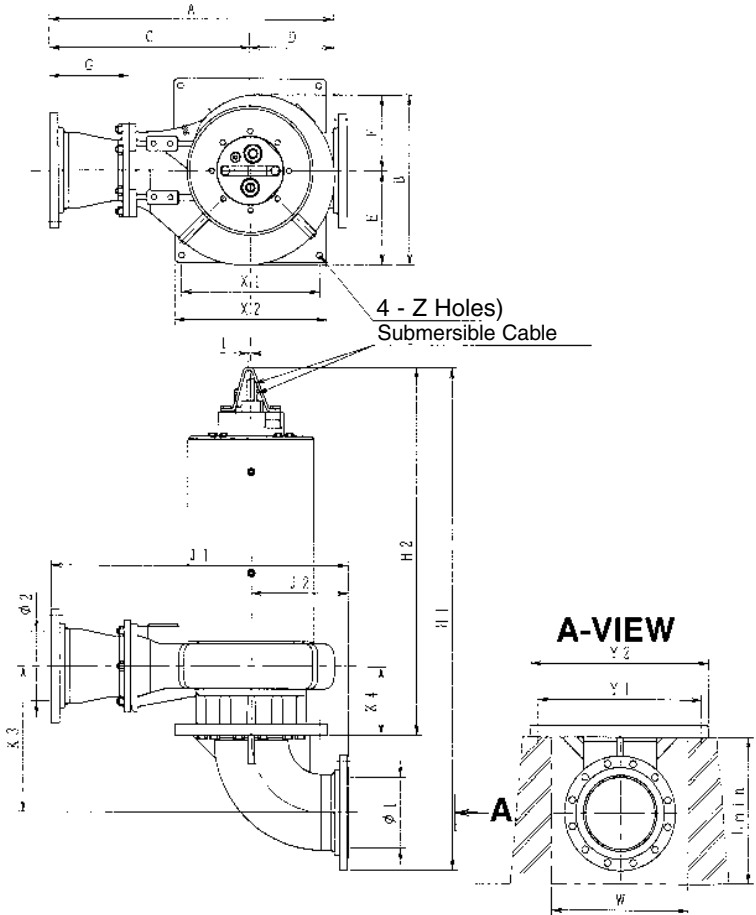

Flange (ANSI 125 PSI F.F)

inch	φ	e	f	t	n	h
10	14 ¹ / ₄	16	1 ³ / ₁₆	12	1	1
12	17	19	1 ¹ / ₄	12	1	1

mm	φ	e	f	t	n	h
250	362	406	30	12	25	25
300	432	483	32	12	25	25

Note: Discharge can be rotated in 30° increments.

Dimensions: inch

PHASE	SIZE		MODEL	OUTPUT		PUMP & MOTOR																	WEIGHT Lb				
	ø1	ø2		KW	HP	A	B	C	D	E	F	G	H ₁	H ₂	I	J ₁	J ₂	K ₃	K ₄	X ₁	X ₂	Y ₁		Y ₂	Z	W	L min.
THREE	10	10	250x250DDLUFU630	30	40	40 ¹ / ₂	23 ¹¹ / ₁₆	28 ⁷ / ₁₆	11 ¹⁵ / ₁₆	13 ³ / ₁₆	10 ¹ / ₂	11 ¹ / ₄	66 ⁵ / ₁₆	47 ¹³ / ₁₆	5 ¹ / ₁₆	42 ³ / ₁₆	13 ³ / ₄	20 ³ / ₈	9 ¹¹ / ₁₆	19 ¹¹ / ₁₆	21 ⁵ / ₈	23 ³ / ₈	25 ⁵ / ₁₆	7 ¹ / ₈	17 ¹¹ / ₁₆	19 ¹¹ / ₁₆	2021
			250x250DDLUFU637	37	50	40 ¹ / ₂	23 ¹¹ / ₁₆	28 ⁷ / ₁₆	11 ¹⁵ / ₁₆	13 ³ / ₁₆	10 ¹ / ₂	11 ¹ / ₄	70 ¹³ / ₁₆	52 ¹ / ₁₆	5 ¹ / ₁₆	42 ³ / ₁₆	13 ³ / ₄	20 ³ / ₈	9 ¹¹ / ₁₆	19 ¹¹ / ₁₆	21 ⁵ / ₈	23 ³ / ₈	25 ⁵ / ₁₆	7 ¹ / ₈	17 ¹¹ / ₁₆	19 ¹¹ / ₁₆	2103
			250x250DDLUFU645	45	60	40 ¹ / ₂	23 ¹¹ / ₁₆	28 ⁷ / ₁₆	11 ¹⁵ / ₁₆	13 ³ / ₁₆	10 ¹ / ₂	11 ¹ / ₄	70 ¹³ / ₁₆	52 ¹ / ₁₆	5 ¹ / ₁₆	42 ³ / ₁₆	13 ³ / ₄	20 ³ / ₈	9 ¹¹ / ₁₆	19 ¹¹ / ₁₆	21 ⁵ / ₈	23 ³ / ₈	25 ⁵ / ₁₆	7 ¹ / ₈	17 ¹¹ / ₁₆	19 ¹¹ / ₁₆	2184
	12	12	300x300DDLUFU630	30	40	46 ¹ / ₂	27 ⁹ / ₁₆	32 ¹¹ / ₁₆	13 ⁹ / ₁₆	15 ³ / ₈	11 ¹⁵ / ₁₆	13	72 ³ / ₁₆	52 ¹ / ₁₆	5 ¹ / ₁₆	48 ⁷ / ₁₆	15 ³ / ₄	24 ⁷ / ₁₆	11 ³ / ₄	21 ⁵ / ₈	23 ³ / ₈	26 ³ / ₈	28 ³ / ₈	7 ¹ / ₈	20 ¹ / ₂	23 ³ / ₈	2266
			300x300DDLUFU637	37	50	46 ¹ / ₂	27 ⁹ / ₁₆	32 ¹¹ / ₁₆	13 ⁹ / ₁₆	15 ³ / ₈	11 ¹⁵ / ₁₆	13	76 ¹ / ₂	55 ¹ / ₂	5 ¹ / ₁₆	48 ⁷ / ₁₆	15 ³ / ₄	24 ⁷ / ₁₆	11 ³ / ₄	21 ⁵ / ₈	23 ³ / ₈	26 ³ / ₈	28 ³ / ₈	7 ¹ / ₈	20 ¹ / ₂	23 ³ / ₈	2347
			300x300DDLUFU645	45	60	46 ¹ / ₂	27 ⁹ / ₁₆	32 ¹¹ / ₁₆	13 ⁹ / ₁₆	15 ³ / ₈	11 ¹⁵ / ₁₆	13	76 ¹ / ₂	55 ¹ / ₂	5 ¹ / ₁₆	48 ⁷ / ₁₆	15 ³ / ₄	24 ⁷ / ₁₆	11 ³ / ₄	21 ⁵ / ₈	23 ³ / ₈	26 ³ / ₈	28 ³ / ₈	7 ¹ / ₈	20 ¹ / ₂	23 ³ / ₈	2429

Dimensions: mm

PHASE	SIZE		MODEL	OUTPUT		PUMP & MOTOR																	WEIGHT kg				
	ø1	ø2		KW	HP	A	B	C	D	E	F	G	H ₁	H ₂	I	J ₁	J ₂	K ₃	K ₄	X ₁	X ₂	Y ₁		Y ₂	Z	W	L min.
THREE	250	250	250x250DDLUFU630	30	40	1029	602	726	304	335	267	285	1693	1218	8	1076	350	518	246	500	550	600	650	23	450	500	917
			250x250DDLUFU637	37	50	1029	602	726	304	335	267	285	1798	1323	8	1076	350	518	246	500	550	600	650	23	450	500	954
			250x250DDLUFU645	45	60	1029	602	726	304	335	267	285	1798	1323	8	1076	350	518	246	500	550	600	650	23	450	500	991
	300	300	300x300DDLUFU630	30	40	1181	693	831	351	391	303	330	1838	1325	8	1231	400	620	298	550	600	670	720	23	520	600	1028
			300x300DDLUFU637	37	50	1181	693	831	351	391	303	330	1943	1410	8	1231	400	620	298	550	600	670	720	23	520	600	1065
			300x300DDLUFU645	45	60	1181	693	831	351	391	303	330	1943	1410	8	1231	400	620	298	550	600	670	720	23	520	600	1102



Sectional View

Project:

Model:

Chk'd:

Date:

15 to 30HP

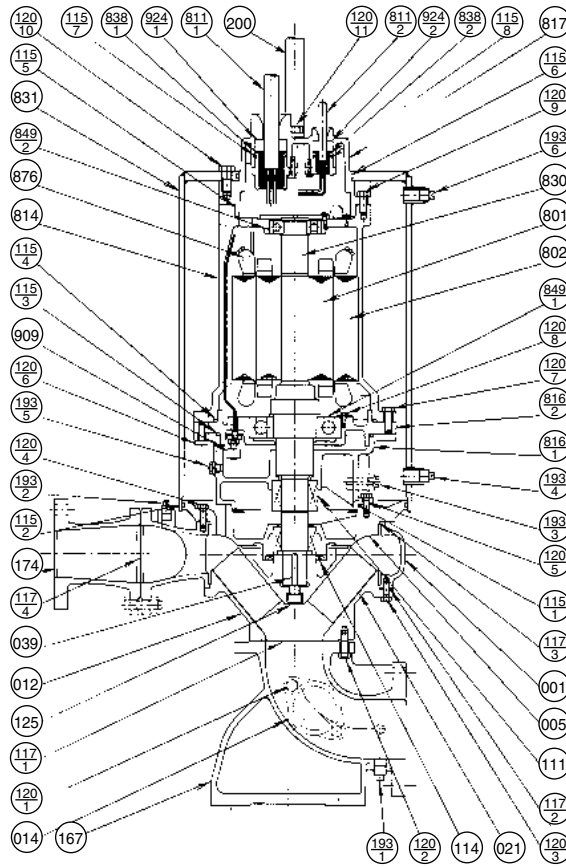

PART NO.	PART NAME	MATERIAL	ASTM, AISI CODE	NO. FOR 1 UNIT
001	CASING	CAST IRON	A48 Class 30	1
005	INTERMEDIATE CASING	CAST IRON	A48 Class 30	1
†012	SUCTION COVER	CAST IRON	A48 Class 30	1
014	HAND HOLE COVER	CAST IRON	A48 Class 30	1
†021	IMPELLER	CAST IRON	A48 Class 30	1
039	KEY	420 STAINLESS	AISI420	1
†111	MECHANICAL SEAL	—		1 SET
†114	OIL SEAL	RUBBER (NBR)		1
†115-1	O-RING	RUBBER (NBR)		1
†115-2	O-RING	RUBBER (NBR)		1
†115-3	O-RING	RUBBER (NBR)		1
†115-4	O-RING	RUBBER (NBR)		1
†115-5	O-RING	RUBBER (NBR)		1
†115-6	O-RING	RUBBER (NBR)		1
†115-7	O-RING	RUBBER (NBR)		1
†115-8	O-RING	RUBBER (NBR)		1
†117-1	GASKET			1
†117-2	GASKET			1
†117-3	GASKET			1
†117-4	GASKET			1
120-1	BOLT	304 STAINLESS	AISI304	2
120-2	BOLT	304 STAINLESS	AISI304	8
120-3	BOLT	304 STAINLESS	AISI304	8
120-4	BOLT	304 STAINLESS	AISI304	8
120-5	BOLT	304 STAINLESS	AISI304	4
120-6	BOLT	304 STAINLESS	AISI304	6
120-7	BOLT	304 STAINLESS	AISI304	6
120-8	BOLT	304 STAINLESS	AISI304	3
120-9	BOLT	304 STAINLESS	AISI304	6
120-10	BOLT	304 STAINLESS	AISI304	6

PART NO.	PART NAME	MATERIAL	ASTM, AISI CODE	NO. FOR 1 UNIT
120-11	BOLT	304 STAINLESS	AISI304	2
125	BOLT	304 STAINLESS	AISI304	1
167	SUCTION ELBOW	CAST IRON	A48 Class 30	1
174	DISCHARGE PIPE	CAST IRON	A48 Class 30	1
193-1	PLUG	STEEL		1
193-2	PLUG	304 STAINLESS	AISI304	1
193-3	PLUG	304 STAINLESS	AISI304	1
193-4	PLUG	304 STAINLESS	AISI304	1
193-5	PLUG	304 STAINLESS	AISI304	1
193-6	PLUG	304 STAINLESS	AISI304	1
200	LIFTING HANGER	STEEL	A283 Grade D	1
801	ROTOR	—		1
802	STATOR	—		1
811-1	POWER CABLE	—		1
811-2	CONTROL CABLE	—		1
814	MOTOR COVER	CAST IRON	A48 Class 30	1
816-1	BRACKET	CAST IRON	A48 Class 30	1
816-2	BRACKET	CAST IRON	A48 Class 30	1
817	BRACKET	CAST IRON	A48 Class 30	1
830	SHAFT	420J2 STAINLESS	AISI420	1
831	WATER JACKET	STEEL	A283 Grade D	1
838-1	WASHER	304 STAINLESS	AISI304	1
838-2	WASHER	304 STAINLESS	AISI304	1
†849-1	BALL BEARING	—		1
†849-2	BALL BEARING	—		1
876	MOTOR PROTECTOR	—		3
909	LEAKAGE DETECTOR	—		1
924-1	PACKING	RUBBER (NBR)		1
924-2	PACKING	RUBBER (NBR)		1

Motors are purchased as a complete unit
†: Recommended spare parts



Sectional View

Project:

Model:

Chk'd:

Date:

40 to 60HP
150 x 100DDLUFU

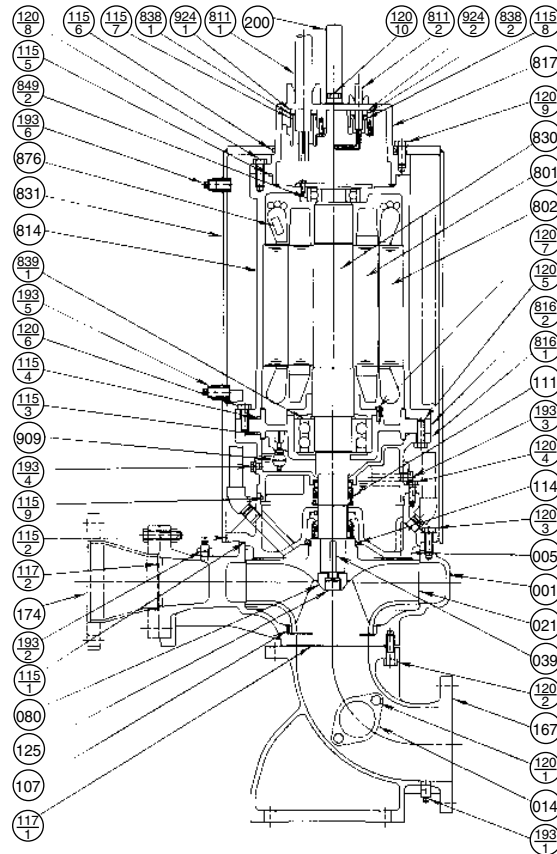

PART NO.	PART NAME	MATERIAL	ASTM, AISI CODE	NO. FOR 1 UNIT
001	CASING	CAST IRON	A48 Class 30	1
005	INTERMEDIATE CASING	CAST IRON	A48 Class 30	1
014	HAND HOLE COVER	CAST IRON	A48 Class 30	1
†021	IMPELLER	CAST IRON	A48 Class 30	1
039	KEY	420 STAINLESS	AISI420	1
†080	BUSHING	304 STAINLESS	AISI304	1
†107	WEARING RING	CAST IRON	A48 Class 30	1
†111	MECHANICAL SEAL	—	—	1 SET
†114	OIL SEAL	RUBBER (NBR)	—	1
†115-1	O-RING	RUBBER (NBR)	—	1
†115-2	O-RING	RUBBER (NBR)	—	1
†115-3	O-RING	RUBBER (NBR)	—	1
†115-4	O-RING	RUBBER (NBR)	—	1
†115-5	O-RING	RUBBER (NBR)	—	1
†115-6	O-RING	RUBBER (NBR)	—	1
†115-7	O-RING	RUBBER (NBR)	—	2
†115-8	O-RING	RUBBER (NBR)	—	1
†115-9	O-RING	RUBBER (NBR)	—	1
†117-1	GASKET	—	—	1
†117-2	GASKET	—	—	1
120-1	BOLT	304 STAINLESS	AISI304	2
120-2	BOLT	304 STAINLESS	AISI304	8
120-3	BOLT	304 STAINLESS	AISI304	8
120-4	BOLT	304 STAINLESS	AISI304	4
120-5	BOLT	304 STAINLESS	AISI304	6
120-6	BOLT	304 STAINLESS	AISI304	6
120-7	BOLT	304 STAINLESS	AISI304	3
120-8	BOLT	304 STAINLESS	AISI304	8
120-9	BOLT	304 STAINLESS	AISI304	8

PART NO.	PART NAME	MATERIAL	ASTM, AISI CODE	NO. FOR 1 UNIT
120-10	BOLT	304 STAINLESS	AISI304	2
125	BOLT	304 STAINLESS	AISI304	1
167	SUCTION ELBOW	CAST IRON	A48 Class 30	1
174	DISCHARGE PIPE	STEEL	A283 Grade D	1
193-1	PLUG	STEEL	—	1
193-2	PLUG	304 STAINLESS	AISI304	1
193-3	PLUG	304 STAINLESS	AISI304	1
193-4	PLUG	304 STAINLESS	AISI304	1
193-5	PLUG	304 STAINLESS	AISI304	1
193-6	PLUG	304 STAINLESS	AISI304	1
200	LIFTING HANGER	STEEL	A283 Grade D	1
801	ROTOR	—	—	1
802	STATOR	—	—	1
811-1	POWER CABLE	—	—	2
811-2	CONTROL CABLE	—	—	1
814	MOTOR COVER	CAST IRON	A48 Class 30	1
816-1	BRACKET	CAST IRON	A48 Class 30	1
816-2	BRACKET	CAST IRON	A48 Class 30	1
817	BRACKET	CAST IRON	A48 Class 30	1
830	SHAFT	420J2 STAINLESS	AISI420	1
831	WATER JACKET	STEEL	A283 Grade D	1
838-1	WASHER	304 STAINLESS	AISI304	2
838-2	WASHER	304 STAINLESS	AISI304	1
†849-1	BALL BEARING	—	—	1 SET
†849-2	BALL BEARING	—	—	1
876	MOTOR PROTECTOR	—	—	3
909	LEAKAGE DETECTOR	—	—	1
924-1	PACKING	RUBBER (NBR)	—	2
924-2	PACKING	RUBBER (NBR)	—	1

Motors are purchased as a complete unit
†: Recommended spare parts



Sectional View

Project: _____ Model: _____ Chk'd: _____ Date: _____

40 to 60HP
200 × 150DDLUFU
200 × 200DDLUFU

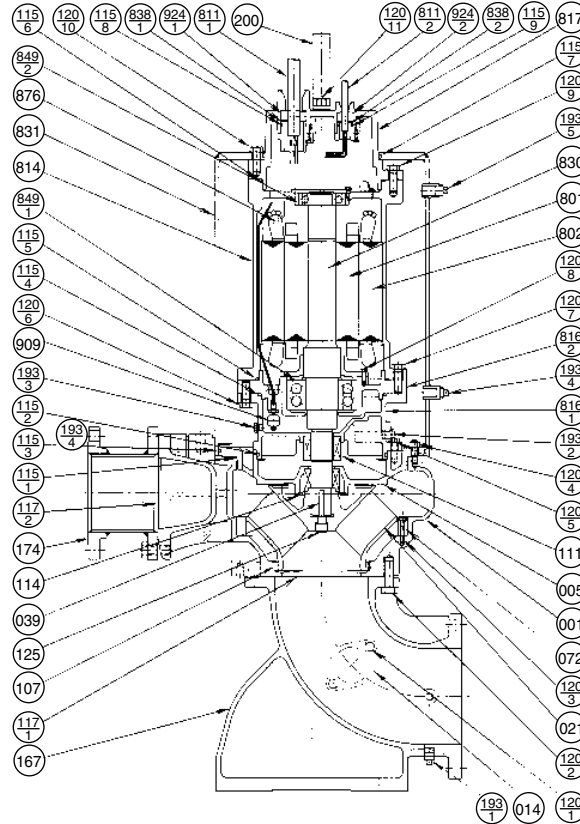

PART NO.	PART NAME	MATERIAL	ASTM, AISI CODE	NO. FOR 1 UNIT	PART NO.	PART NAME	MATERIAL	ASTM, AISI CODE	NO. FOR 1 UNIT
001	CASING	CAST IRON	A48 Class 30	1	120-10	BOLT	304 STAINLESS	AISI304	8
005	INTERMEDIATE CASING	CAST IRON	A48 Class 30	1	120-11	BOLT	304 STAINLESS	AISI304	2
014	HAND HOLE COVER	CAST IRON	A48 Class 30	1	125	BOLT	304 STAINLESS	AISI304	1
†021	IMPELLER	CAST IRON	A48 Class 30	1	167	SUCTION ELBOW	CAST IRON	A48 Class 30	1
039	KEY	420 STAINLESS	AISI420	1	174	DISCHARGE PIPE	STEEL	A283 Grade D	1
†072	UPPER CASE RING	CAST IRON	A48 Class 30	1	193-1	PLUG	STEEL		1
†107	LOWER CASE RING	304 STAINLESS	AISI304	1	193-2	PLUG	304 STAINLESS	AISI304	1
†111	MECHANICAL SEAL	—		1 SET	193-3	PLUG	304 STAINLESS	AISI304	1
†114	OIL SEAL	RUBBER (NBR)		1	193-4	PLUG	304 STAINLESS	AISI304	1
†115-1	O-RING	RUBBER (NBR)		1	193-5	PLUG	304 STAINLESS	AISI304	1
†115-2	O-RING	RUBBER (NBR)		1	200	LIFTING HANGER	STEEL	A283 Grade D	1
†115-3	O-RING	RUBBER (NBR)		1	801	ROTOR	—		1
†115-4	O-RING	RUBBER (NBR)		1	802	STATOR	—		1
†115-5	O-RING	RUBBER (NBR)		1	811-1	POWER CABLE	—		2
†115-6	O-RING	RUBBER (NBR)		1	811-2	CONTROL CABLE	—		1
†115-7	O-RING	RUBBER (NBR)		1	814	MOTOR COVER	CAST IRON	A48 Class 30	1
†115-8	O-RING	RUBBER (NBR)		2	816-1	BRACKET	CAST IRON	A48 Class 30	1
†115-9	O-RING	RUBBER (NBR)		1	816-2	BRACKET	CAST IRON	A48 Class 30	1
†117-1	GASKET			1	817	BRACKET	CAST IRON	A48 Class 30	1
†117-2	GASKET			1	830	SHAFT	420J2 STAINLESS	AISI420	1
120-1	BOLT	304 STAINLESS	AISI304	2	831	WATER JACKET	STEEL	A283 Grade D	1
120-2	BOLT	304 STAINLESS	AISI304	12	838-1	WASHER	304 STAINLESS	AISI304	2
120-3	BOLT	304 STAINLESS	AISI304	4	838-2	WASHER	304 STAINLESS	AISI304	1
120-4	BOLT	304 STAINLESS	AISI304	8	†849-1	BALL BEARING	—		1 SET
120-5	BOLT	304 STAINLESS	AISI304	4	†849-2	BALL BEARING	—		1
120-6	BOLT	304 STAINLESS	AISI304	8	876	MOTOR PROTECTOR	—		3
120-7	BOLT	304 STAINLESS	AISI304	8	909	LEAKAGE DETECTOR	—		1
120-8	BOLT	304 STAINLESS	AISI304	4	924-1	PACKING	RUBBER (NBR)		2
120-9	BOLT	304 STAINLESS	AISI304	6	924-2	PACKING	RUBBER (NBR)		1

Motors are purchased as a complete unit
 †: Recommended spare parts



Sectional View

Project:

Model:

Chk'd:

Date:

40 to 60HP
250 × 250DDLUFU
300 × 300DDLUFU

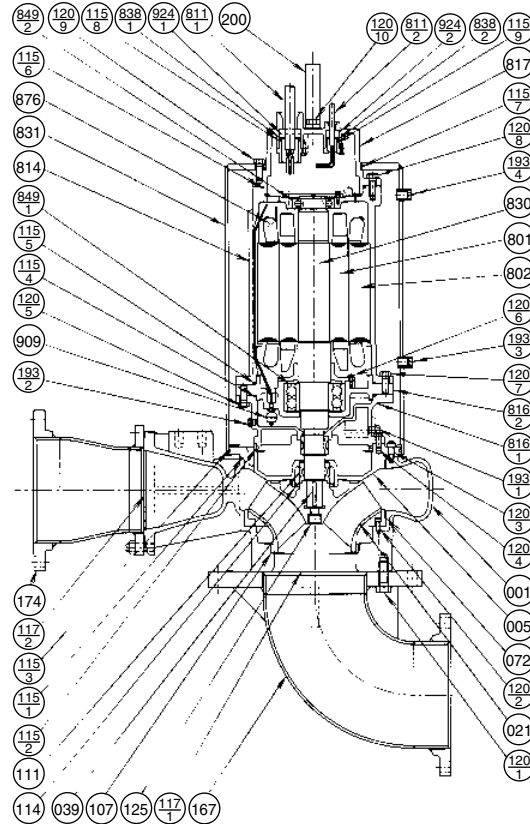

PART NO.	PART NAME	MATERIAL	ASTM, AISI CODE	NO. FOR 1 UNIT
001	CASING	CAST IRON	A48 Class 30	1
005	INTERMEDIATE CASING	CAST IRON	A48 Class 30	1
†021	IMPELLER	CAST IRON	A48 Class 30	1
039	KEY	420 STAINLESS	AISI420	1
†072	UPPER CASE RING	CAST IRON	A48 Class 30	1
†107	LOWER CASE RING	304 STAINLESS	AISI304	1
†111	MECHANICAL SEAL	—	—	1 SET
†114	OIL SEAL	RUBBER (NBR)	—	1
†115-1	O-RING	RUBBER (NBR)	—	1
†115-2	O-RING	RUBBER (NBR)	—	1
†115-3	O-RING	RUBBER (NBR)	—	1
†115-4	O-RING	RUBBER (NBR)	—	1
†115-5	O-RING	RUBBER (NBR)	—	1
†115-6	O-RING	RUBBER (NBR)	—	1
†115-7	O-RING	RUBBER (NBR)	—	1
†115-8	O-RING	RUBBER (NBR)	—	2
†115-9	O-RING	RUBBER (NBR)	—	1
†117-1	GASKET	—	—	1
†117-2	GASKET	—	—	1
120-1	BOLT	304 STAINLESS	AISI304	12
120-2	BOLT	304 STAINLESS	AISI304	4
120-3	BOLT	304 STAINLESS	AISI304	8
120-4	BOLT	304 STAINLESS	AISI304	4
120-5	BOLT	304 STAINLESS	AISI304	8
120-6	BOLT	304 STAINLESS	AISI304	4
120-7	BOLT	304 STAINLESS	AISI304	8
120-8	BOLT	304 STAINLESS	AISI304	6
120-9	BOLT	304 STAINLESS	AISI304	8

PART NO.	PART NAME	MATERIAL	ASTM, AISI CODE	NO. FOR 1 UNIT
120-10	BOLT	304 STAINLESS	AISI304	2
125	BOLT	304 STAINLESS	AISI304	1
167	SUCTION ELBOW	STEEL	A283 Grade D	1
174	DISCHARGE PIPE	STEEL	A283 Grade D	1
193-1	PLUG	304 STAINLESS	AISI304	1
193-2	PLUG	304 STAINLESS	AISI304	1
193-3	PLUG	304 STAINLESS	AISI304	1
193-4	PLUG	304 STAINLESS	AISI304	1
200	LIFTING HANGER	STEEL	A283 Grade D	1
801	ROTOR	—	—	1
802	STATOR	—	—	1
811-1	POWER CABLE	—	—	2
811-2	CONTROL CABLE	—	—	1
814	MOTOR COVER	CAST IRON	A48 Class 30	1
816-1	BRACKET	CAST IRON	A48 Class 30	1
816-2	BRACKET	CAST IRON	A48 Class 30	1
817	BRACKET	CAST IRON	A48 Class 30	1
830	SHAFT	420J2 STAINLESS	AISI420	1
831	WATER JACKET	STEEL	A283 Grade D	1
838-1	WASHER	304 STAINLESS	AISI304	2
838-2	WASHER	304 STAINLESS	AISI304	1
†849-1	BALL BEARING	—	—	1 SET
†849-2	BALL BEARING	—	—	1
876	MOTOR PROTECTOR	—	—	3
909	LEAKAGE DETECTOR	—	—	1
924-1	PACKING	RUBBER (NBR)	—	2
924-2	PACKING	RUBBER (NBR)	—	1

Motors are purchased as a complete unit
 †: Recommended spare parts

